

radicon

with you at every turn

benzlers

with you at every turn

Series A Junior Worm Gear

BCI_{nv}
elektromotoren



Technical
Up to - 12kW / 950 Nm

Worm Gears
CAJ-2.00GB0218

PRODUCTS IN THE RANGE

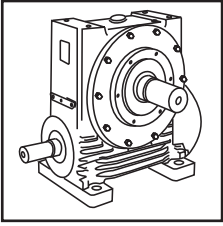

Series A
Worm Gear units
and geared motors
in single & double
reduction types

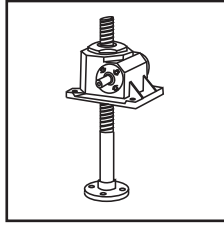

Series BD
Screwjack worm
gear unit

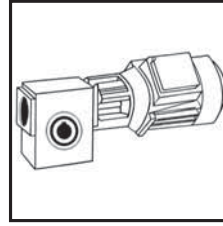

Series BS
Worm gear unit

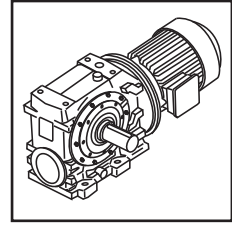

Series C
Right angle drive
helical worm geared
motors & reducers

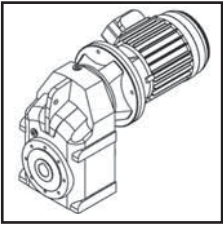

Series F
Parallel shaft helical
geared motors &
reducers

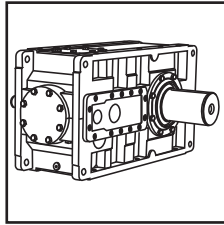

Series G
Helical parallel shaft
& bevel helical right
angle drive gear
units

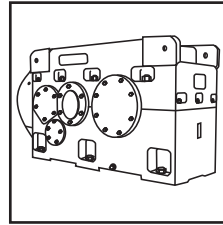

Series H
Large helical parallel
shaft & bevel helical
right angle drive units

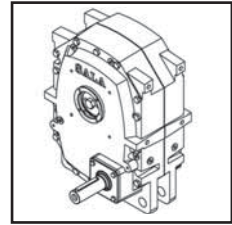

Series J
Shaft mounted
helical speed
reducers

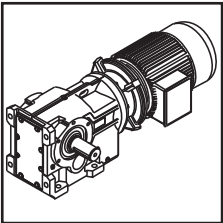

Series K
Right angle helical
bevel helical geared
motors & reducers

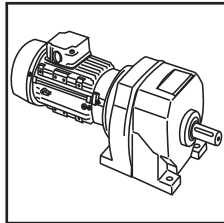

Series M
In-line helical geared
motors & reducers

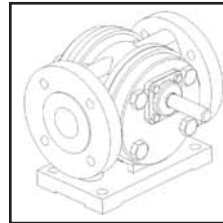

Roloid Gear Pump
Lubrication and fluid
transportation pump

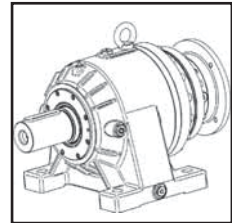

Series P
Planetary
Foot and flange
mounted planetary
units

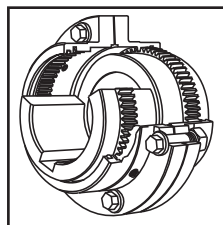

Series X
Elign Gear
Torsionally rigid,
high torque coupling

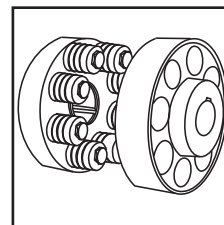

Series X
Elflex
Pin and bush
elastomer coupling

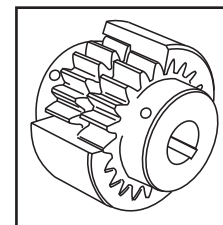

Series X
Nylicon
Gear coupling with
nylon sleeve

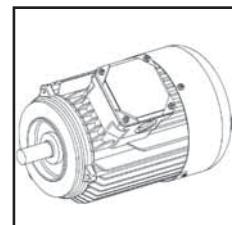

Motors
Full range of IEC
motors



We offer a wide range of repair services and many years experience of repairing demanding and highly critical transmissions in numerous industries.

We can create custom engineered transmission solutions of any size and configuration.

CONTENTS PAGE

General Description _____	3
Unit Designations _____	4
Explanation and use of Ratings and Service Factors _____	5
Load Classification by Applications _____	6
Moments of Inertia _____	7
Lubrication _____	8
Selection Procedure _____	9 - 12
Mounting Positions _____	13 - 15
Exact Ratios _____	16
Output Options _____	17
Motor Adaptors / Additional Features _____	18
Series X Couplings _____	19
MOTORISED	
Motor Performance Data and Standard Motor Variants Available _____	21 - 22
Brake Motors / Motors Available _____	23
Motor Details _____	24
Selection Tables - Geared Motors _____	25 - 38
Dimension Sheets - Geared Motors _____	39 - 45
REDUCER	
Overhung and Axial Loads on Shafts _____	47 - 48
Ratings - Input Power / Output Torque _____	49 - 72
Dimension Sheets - Speed Reducers _____	73 - 79
Case with Additional Machined Spigot _____	80
Torque Arm _____	81
Shipping Specification _____	82

GENERAL DESCRIPTION

Single Reduction Units (worm)

Series A Junior is offered in unit sizes 280, 410, 510, 610, 730 and 860 based on a single universal case for each size, giving a high degree of common parts and interchangeability. Units can be mounted in the under driven, over driven and vertical mounting positions and provide a choice of shaft arrangements for either motorised or reducer versions. Motors can be close coupled in frame sizes 63 to 132 in powers from 0.12 kW to 11 kW.

All units are designed with hollow output bores, output shafts can be fitted allowing handing to be changed without dismantling the unit. Double extended output shafts are also available.

Series A Junior gives a choice of 12 standard ratios from 5/1 to 70/1 and important features include high efficiencies and load carrying capacities combined with long life and reliability.

All units are lubricated for life to reduce maintenance to a minimum.

Double Reduction Units (worm/worm)

These units consist of a standard single reduction unit with a smaller shaft mounted Series A unit fitted to the input shaft. The range extends the ratios available up to the maximum of 4200/1 making them ideal for fitting to slow moving machinery.

As with the single reduction units they are available in underdriven, over-driven and vertical types, foot mounting and shaft mounting. All lubricated for life.

Motorised Units

Units are designed to be close coupled with standard dimension IEC motors. Units are also available to accept standard dimension NEMA motors (consult our Application Engineers).

Lubricated for life - fit and forget

Series A Junior units are factory filled with synthetic lubricant which means.

- no oil level checks, topping up, draining or re-filling
- no routine maintenance or danger of starting up without lubricant
- they will mount in any location, however inaccessible
- they are particularly suitable for locations where non contamination through leakage is essential.

For units running at input speeds below 500 rev/min with either the input or output shaft vertical, also for the second stage of all double reduction units irrespective of shaft disposition the lubricant level is simply increased - see lubrication instructions.

As improvements in design are being made continually this specification is not to be regarded as binding in detail and drawings and capacities are subject to alteration without notice. Certified drawings will be sent on request.

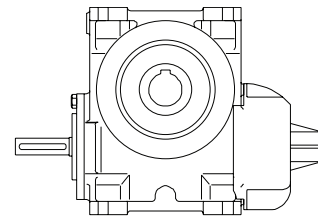

Single Reduction Units (worm)

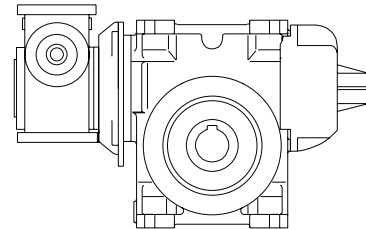

Double Reduction Units (worm/ worm)

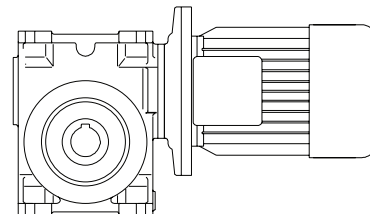

Motorised Single Reduction Units (worm)

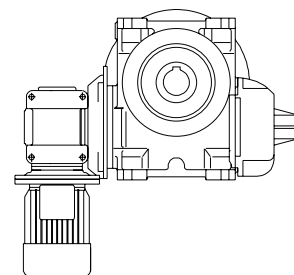

Motorised Double Reduction Units (worm/ worm)

UNIT DESIGNATIONS

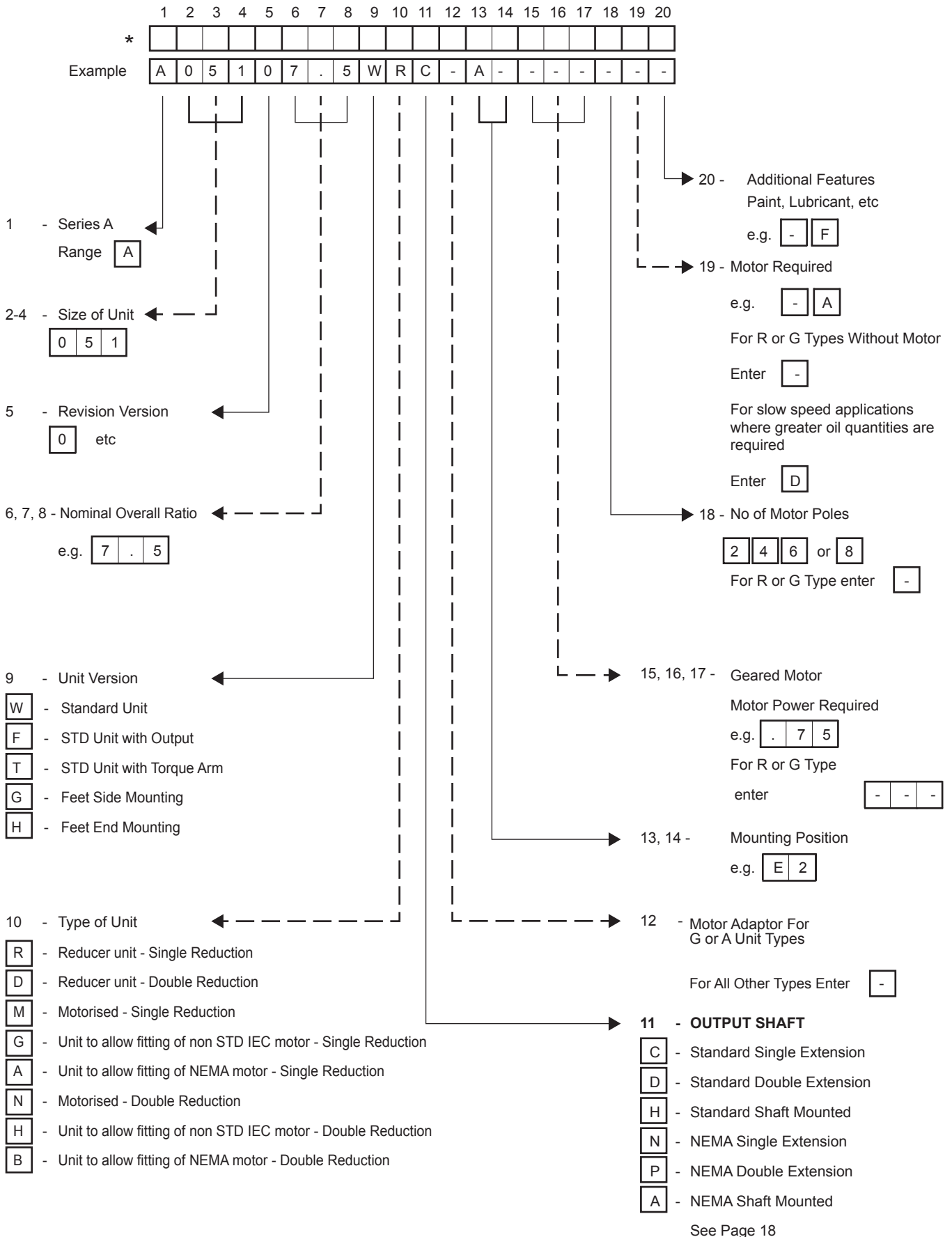

* This Page May Be Photocopied Allowing The Customer To Enter Their Order
To access the on line configurator please visit www.swift-gears.com

Gear unit selection is made by comparing actual loads with catalogue ratings. Catalogue ratings are based on a standard set of loading conditions, whereas actual load conditions vary according to type of application. Service Factors are therefore used to calculate an equivalent load to compare with catalogue ratings. i.e. Equivalent Load = Actual Load x Service Factor

Two types of Service Factor must be considered:-

Mechanical Service Factor Fm and Thermal Service Factors Ft, Fp and Fd

Mechanical ratings and service factors Fm

Mechanical ratings measure capacity in terms of life and/or strength, assuming 10 hr/day continuous running under uniform load conditions.

Catalogue ratings allow 100% overload at starting, braking or momentarily during operation up to 10 hours per day.

The unit selected must therefore have a catalogue rating at least equal to half maximum overload.

Mechanical Service Factor Fm (Table 1) is used to modify the actual load according to daily operating time, and type of loading.

Load characteristics for a wide range of applications are detailed in Table 5 opposite, which are used in deciding the appropriate Service Factor Fm from Table 1.

If overloads can be calculated, or accurately assessed, actual load should be used instead of Fm.

For units subject to frequent stop/start overloads in excess of 10 times per day, refer to our Application Engineers.

For applications where high inertia loads are involved e.g. crane travel drives, slewing motion etc., unit selection should be referred to our Application Engineers.

Thermal ratings and service factors

The Thermal ratings are a measure of the gear units ability to dissipate heat. If they are exceeded the lubricant may overheat and breakdown, resulting in gear failure.

Thermal service factors are used for reducer units only. Sizes A0730 and A0860 are fitted with fans as standard if these sizes are required without fans refer to our Application Engineers.

Motorised unit ratings assume a standard motor fitted which is T.E.F.C.

Catalogue thermal limitations are based on the unit operating continuously in an environment with an ambient temperature equal to 20°C and in mounting position A, B or C. The thermal rating is affected by ambient temperature, duration of running per hour and mounting position. To account for these varying conditions, the service factors given in tables 2, 3 and 4 should be applied to the catalogue thermal ratings as follows:-

$$T_{\text{therm}} = T_t \times F_t \times F_p \times F_d$$

$$T_t = \text{Catalogue output torque thermal rating (Nm)}$$

$$T_{\text{therm}} = \text{Allowable output torque thermal rating (Nm)}$$

$$F_t = \text{Service factor for ambient temperature (see Table 2)}$$

$$F_p = \text{Service factor for different mounting positions (see Table 3)}$$

$$F_d = \text{Thermal service factor for duration of running (see Table 4)}$$

Double Reduction Units

For double reduction units the factors given in tables 2 and 4 apply. The input shaft speed referred to in table 4 should now be the input speed of the primary unit. The following new thermal service factors, Fp, should be applied. In each case the description refers to the position of the primary unit.

$$\text{i Inputshaft horizontal and wheel- line horizontal} \quad F_p = 1.0$$

$$\text{ii Inputshaft horizontal and wheel-line vertical} \quad F_p = 0.88$$

$$\text{iii Inputshaft vertical and wheel-line horizontal} \quad F_p = 0.68$$

General

When selecting units, use actual load required to be transmitted, not rating of prime mover. Wherever possible use required output torque (Nm). Catalogue also gives input power rating (kW), being power required from mover allowing for gear unit efficiency. When units transmit less than rated output torque, required input power may be reduced pro-rata to decide capacity of prime mover.

Table 1. Mechanical service factors Fm

Prime mover	Duration of service - hrs per day	Load classification-driven machine		
		Uniform	Moderate Shock	Heavy Shock
Electric motor, steam turbine or hydraulic motor	Under 3	0.80	1.00	1.50
	3 to 10	1.00	1.25	1.75
	Over 10	1.25	1.50	2.00
Multi-cylinder internal combustion engine	Under 3	1.00	1.25	1.75
	3 to 10	1.25	1.50	2.00
	Over 10	1.50	1.75	2.25
Single cylinder internal combustion engine	Under 3	1.25	1.50	2.00
	3 to 10	1.50	1.75	2.25
	Over 10	1.75	2.00	2.50

Table 2. Thermal Service Factors Ft

Ambient temperature °C	-30	-20	-10	0	10	20	30	40	50
Factor Ft	1.65	1.52	1.39	1.26	1.14	1.0	0.86	0.73	0.60

Table 3. Thermal Service Factors Fp (Single Reduction Units)

Output Speed (Rev/min)	Mounting Position (See pages 14 and 15)			
	ABC	DEF	GHJ KMN	PST WXY
0 to 100	1.0	1.0	1.0	Refer to our Applications Department
>100 to 200	1.0	1.0	1.0	
>200 to 300	1.0	1.0	1.0	
>300 to 400	1.0	1.0	1.0	
>400 to 500	1.0	1.0	1.0	
>500 to 600	1.0	1.0	1.0	
>600 to 700	1.0	1.0	1.0	
>700	1.0	1.0	1.0	

Table 4. Thermal Service Factors Fd

Input shaft speed (Rev/min)	Unit Size	% Running time per hour					
		>60	>50 - 60	>40 - 50	>30 - 40	>20 - 30	<20
100	280 - 610	1.0	1.46	1.72	1.96	2.32	2.86
	730	1.0	1.45	1.68	1.92	2.26	2.74
	860	1.0	1.46	1.72	1.96	2.32	2.86
400	280 - 610	1.0	1.46	1.72	1.96	2.32	2.86
	730	1.0	1.40	1.59	1.80	2.07	2.47
	860	1.0	1.46	1.72	1.96	2.32	2.86
725	280 - 610	1.0	1.46	1.72	1.96	2.32	2.86
	730	1.0	1.34	1.50	1.66	1.88	2.21
	860	1.0	1.41	1.61	1.82	2.12	2.53
960	280 - 610	1.0	1.46	1.72	1.96	2.32	2.86
	730	1.0	1.32	1.46	1.61	1.81	2.14
	860	1.0	1.38	1.56	1.75	2.02	2.38
1160	280 - 610	1.0	1.46	1.72	1.96	2.32	2.86
	730	1.0	1.30	1.43	1.56	1.75	2.05
	860	1.0	1.37	1.54	1.72	1.96	2.32
1450	280 - 610	1.0	1.46	1.72	1.96	2.32	2.86
	730	1.0	1.28	1.39	1.52	1.69	1.97
	860	1.0	1.34	1.50	1.66	1.88	2.21
1750	280 - 610	1.0	1.46	1.72	1.96	2.32	2.86
	730	1.0	1.26	1.36	1.47	1.63	1.89
	860	1.0	1.32	1.46	1.61	1.81	2.14
2900	280 - 610	1.0	1.46	1.72	1.98	2.32	2.86
	730	1.0	1.20	1.28	1.36	1.48	1.68
	860	1.0	1.27	1.38	1.50	1.66	1.93

LOAD CLASSIFICATION BY APPLICATIONS

Table 5

U = Uniform load

M = Moderate shock load

H = Heavy shock load

† = Refer to Application Engineering

Driven Machine	type of load	Driven Machine	type of load	Driven Machine	type of load
Agitators		Dry dock cranes		log haul-incline	H
pure liquids	U	main hoist	†	log haul-well type	H
liquids and solids	M	auxiliary hoist	†	log turning device	H
liquids-variable density	M	boom, luffing	†	main log conveyor	H
		rotating, swing or slew	†	off bearing rolls	M
		tracking, drive wheels	†	planer feed chains	M
Blowers				planer floor chains	M
centrifugal	U	Elevators		planer tilting hoist	M
lobe	M	bucket-uniform load	U	re-saw merry-go-round	M
vane	U	bucket-heavy load	M	conveyor	M
		bucket-continuous	U	roll cases	H
Brewing and distilling		centrifugal discharge	U	slab conveyor	H
bottling machinery	U	escalators	U	small waste	U
brew kettles-continuous	U	freight	M	conveyor-belt	M
duty	U	gravity discharge	U	small waste	M
cookers-continuous duty	U	man lifts	†	conveyor-chain	M
mash tubs-continuous	U	passenger	†	sorting table	M
duty	U			tipple hoist conveyor	M
scale hopper-frequent	M	Fans		tipple hoist drive	M
starts	M	centrifugal	U	transfer conveyors	M
		cooling towers		transfer rolls	M
		induced draft	†	tray drive	M
		forced draft	†	trimmer feed	M
		induced draft	M	waste conveyor	M
Can filling machines	U	large, mine, etc	M		
		large, industrial	M	Machine tools	
		light, small diameter	U	bending roll	M
Cane knives	M			punch press-gear driven	H
				notching press- belt	†
Car dumpers	H	Feeders		driven	†
		apron	M	plate planers	H
Car pullers	M	belt	U	tapping machine	H
		disc	M	other machine tools	
Clarifiers	U	reciprocating	H	main drives	M
		screw	M	auxiliary drives	U
Classifiers	M				
Clay working machinery		Food industry		Metal mills	
brick press	H	beef slicer	M	draw bench carriage	
briquette machine	H	cereal cooker	U	and main drive	M
clay working machinery	M	dough mixer	M	pinch, dryer and	
pug mill	M	meat grinders	M	scrubber rolls-reversing	†
				slitters	M
Compressors		Generators-not welding	U	table conveyors	
centrifugal	U			non-reversing	
lobe	M	Hammer mills	H	group drives	M
reciprocating				individual drives	H
multi-cylinder	M	Hoists		reversing	
single cylinder	H	heavy duty	H	wire drawing and	
		medium duty	M	flattening machine	M
Conveyors-uniformly loaded or fed		skip hoist	M	wire winding machine	M
apron	U				
assembly	U	Laundry washers		Mill-rotary type	
belt	U	reversing	M	ball	H
bucket	U			cement kilns	H
chain	U	Laundry tumblers	M	dryers and coolers	H
flight	U			kilns, other than cement	H
oven	U	Line shafts		pebble	H
screw	U	driving processing	M	rod	
		equipment	M	plain	H
		light	U	wedge bar	H
		other line shafts	U	tumbling barrels	H
Conveyors-heavy duty not uniformly fed					
apron	M	Lumber industry		Mixers	
assembly	M	barkers-hydraulic-		concrete mixers	
belt	M	mechanical	M	-continuous	M
bucket	M	burner conveyor	M	concrete mixers	M
chain	M	chain saw and drag saw	H	-intermittent	M
chain transfer	M			constant density	U
craneway transfer	M			variable density	M
de-barking drum	M				
edger feed	M			Oil industry	
gang feed	M			chillers	M
green chain	M			oil well pumping	†
live rolls	H			paraffin filter press	M
log deck	H			rotary kilns	M
				Paper mills	
				agitators, (mixers)	M
				barker-auxiliaries-	
				hydraulic	M
				barker-mechanical	H
				barking drum	H
				beater and pulper	M
				bleacher	U
				calenders	M
				calenders-super	H
				converting machine,	
				except cutters, platers	M
				conveyors	U
				couch	M
				cutters-plates	H
				cylinders	M
				dryers	M
				felt stretcher	M
				felt whipper	H
				jordans	M
				log haul	H
				presses	M
				pulp machine reel	M
				stock chest	M
				suction roll	M
				washers and thickeners	M
				winders	M
				Printing presses	†
				Pullers	
				barge haul	H
				Pumps	
				centrifugal	U
				proportioning	M
				reciprocating	
				single acting; 3 or	
				more cylinders	M
				double acting; 2 or	
				more cylinders	M
				single acting; 1 or 2	
				cylinders	†
				double acting; single	
				cylinder	†
				rotary	
				gear type	U
				lobe, vane	U
				Rubber and plastics industries	
				crackers	H
				laboratory equipment	M
				mixed mills	H
				refiners	M
				rubber calenders	M
				rubber mill-2 on line	M
				rubber mill-3 on line	M
				sheeter	M
				tire building machines	†
				tire and tube press	
				openers	†
				tubers and strainers	M
				warming mills	M
				Sand muller	M
				Sewage disposal equipment	
				bar screens	U
				chemical feeders	U
				collectors	U
				dewatering screws	M
				scum breakers	M
				slow or rapid mixers	M
				thickeners	M
				vacuum filters	M
				Screens	
				air washing	U
				rotary-stone or gravel	M
				travelling water intake	U
				Slab pushers	M
				Steering gear	†
				Stokers	U
				Sugar industry	
				cane knives	M
				crushers	M
				mills	M
				Textile industry	
				batchers	M
				calenders	M
				cards	M
				dry cans	M
				dryers	M
				dyeing machinery	M
				knitting machines	†
				looms	M
				mangles	M
				nappers	M
				pads	M
				range drives	†
				slashers	M
				soapers	M
				spinners	M
				tenter frames	M
				washers	M
				winders	M
				Windlass	†

MOMENTS OF INERTIA

MOMENTS OF INERTIA (Kg cm²) Referred to Input Shaft

Single Reduction

RATIO	A0280	A0410	A0510	A0610	A0730	A0860
5.0	0.06	0.40	1.18	2.47	5.77	13.68
7.5	0.05	0.29	0.67	1.40	3.58	7.84
10.0	0.04	0.22	0.49	0.96	2.33	5.77
12.5	0.04	0.21	0.41	0.77	2.22	4.21
15.0	0.03	0.20	0.31	0.63	1.91	4.28
20.0	0.04	0.15	0.42	0.74	1.46	3.23
25.0	0.03	0.18	0.36	0.63	1.92	4.23
30.0	0.03	0.16	0.27	0.53	1.48	3.45
40.0	0.03	0.14	0.20	0.40	1.24	2.94
50.0	0.03	0.13	0.19	0.34	1.11	2.54
60.0	0.03	0.13	0.17	0.29	1.09	2.38
70.0	0.02	0.12	0.16	0.28	1.07	2.40

Double Reduction

RATIO	A0410	A0510	A0610	A0730	A0860
75.0	0.03	0.04	0.19	0.24	0.40
100.0	0.03	0.04	0.20	0.22	0.35
125.0	0.03	0.04	0.19	0.24	0.40
150.0	0.03	0.03	0.17	0.18	0.34
200.0	0.03	0.03	0.17	0.18	0.34
225.0	0.03	0.03	0.17	0.18	0.23
250.0	0.03	0.03	0.17	0.18	0.34
300.0	0.04	0.04	0.13	0.14	0.38
350.0	0.03	0.03	0.18	0.18	0.32
375.0	0.03	0.03	0.17	0.20	0.23
400.0	0.04	0.04	0.13	0.14	0.38
450.0	0.03	0.03	0.17	0.17	0.23
500.0	0.04	0.04	0.13	0.14	0.38
600.0	0.04	0.04	0.13	0.14	0.38
625.0	0.03	0.03	0.17	0.17	0.33
700.0	0.02	0.02	0.12	0.12	0.15
750.0	0.03	0.03	0.17	0.17	0.33
800.0	0.03	0.03	0.14	0.14	0.19
900.0	0.03	0.03	0.16	0.16	0.25
1000.0	0.03	0.03	0.14	0.14	0.19
1200.0	0.03	0.03	0.14	0.14	0.19
1250.0	0.03	0.03	0.13	0.13	0.18
1400.0	0.02	0.02	0.12	0.12	0.15
1500.0	0.03	0.03	0.13	0.13	0.18
1600.0	0.03	0.03	0.14	0.14	0.19
1750.0	0.02	0.02	0.12	0.12	0.15
1800.0	0.03	0.03	0.13	0.13	0.17
2000.0	0.03	0.03	0.13	0.13	0.18
2100.0	0.02	0.02	0.12	0.12	0.15
2400.0	0.03	0.03	0.13	0.13	0.17
2500.0	0.03	0.03	0.13	0.13	0.18
2800.0	0.02	0.02	0.12	0.12	0.15
3000.0	0.03	0.03	0.13	0.13	0.17
3500.0	0.02	0.02	0.12	0.12	0.15
3600.0	0.03	0.03	0.13	0.13	0.17
4200.0	0.02	0.02	0.12	0.12	0.15

LUBRICATION

Series A Junior units are factory filled with a Polyglycol based synthetic lubricant. They are "Lubricated for Life" and require no routine maintenance in service.

In the event of a major overhaul involving strip-down and re-assembly of the gear unit refer to Table 1 for a list of approved lubricants. Lubricant quantities are given in Tables 2 and 3.

Table 1 Approved Lubricants

Type G Polyglycol based synthetic lubricants with Anti-Wear or EP additives

These lubricants are suitable for ambient temperatures of 0oC to 40oC; outside of this, please consult our Application Engineers

SUPPLIER	LUBRICAT RANGE	GRADE 6G
		OIL SUPPLIERS' CORRESPONDING DESIGNATIONS
Boxer Services / Millers Oils	Boxergear W	320 (-31)
Caltex	Synlube CLP	320 (-31)
Carl Bechem GmbH	Berusynth EP	320 (-25)
Castrol International	Alphasyn PG	320 (-31)
Esso/Exxon	Glycolube	320 (-25)
Fuchs Lubricants	Renolin PG	320 (-34)
Klüber Lubrication	Klübersynth GH6	320 (-25)
	Klübersynth UH1 6	320 (-25)
Kuwait Petroleum International	Q8 Gade	320 (-22)
Laporte Performance Chemicals	Breox Industrial Lubricant SW	320 (-25)
	Breox SL range	320 (-37)
Mobil Oil Company Limited	Glygoyle	HE320 (-37)
Optimol Ölwerke GmbH	Optiflex A	320 (-28)
Shell Oils	Tivela	SC (-25)
	Tivela S	320 (-34)
Texaco Limited	Synlube CLP	320 (-31)
Total	Carter SY	320 (-28)
Tribol GmbH	Tribol 800	320 (-25)

DANGER Numbers in brackets indicate recommended minimum operating temperature in °C.

THE UNIT MUST NOT RUN BELOW THIS TEMPERATURE.

Table 2 Lubricant Quantities (Litres)

Applicable for all mounting positions:-

MOTORISED or REDUCER	UNIT SIZE					
	A0280	A0410	A0510	A0610	A0730	A0860
Oil Capacity (Litres)	0.24	0.38	0.56	1.00	2.02	3.10

Table 3 Lubricant Quantities (Litres)

For units running at input speeds below 500 rev/min with either the input or output shaft vertical, also for the secondary stage of all double reduction units irrespective of shaft disposition, the oil quantities in Table 3 below are applicable:-

MOTORISED or REDUCER	UNIT SIZE					
	A0280	A0410	A0510	A0610	A0730	A0860
Oil Capacity (Litres)	0.31	0.48	0.74	1.28	2.62	3.94

SELECTION PROCEDURE FOR MOTORISED UNITS

EXAMPLE APPLICATION DETAILS

Absorbed power of driven machine = 0.38kW
 Output speed of gearbox or Input speed of machine = 55rev/min
 Application = Uniformly loaded belt conveyor
 Duration of service (hours per day) = 24hrs
 Mounting position = D
 Ambient temperature = 20°C
 Running time (%) = 100%

1 DETERMINE MECHANICAL SERVICE FACTOR (Fm)

Refer to Load Classification by Application, table 5, page 7

Application = Uniformly loaded belt conveyor

Conveyors-uniformly loaded or fed

apron assembly	U	U = Uniform load
belt	U	
bucket	U	
chain	U	
	U	

Refer to mechanical service factor (Fm), table 1, page 6

Duration of service (hours per day) = 24hrs

Prime mover	Duration of service-hrs per day	Load classification-drive	
		Uniform	Moderate Shock
Electric motor, steam turbine or hydraulic motor	Under 3	0.80	1.00
	3 to 10	1.00	1.25
	Over 10	1.25	1.50

Therefore mechanical service factor (Fm) = 1.25

2 DETERMINE REQUIRED OUTPUT TORQUE AT GEARBOX OUTPUTSHAFT

$$\text{Absorbed output torque} = \frac{\text{Absorbed power} \times 9550}{\text{Gearbox output speed}}$$

$$\frac{0.38 \times 9550}{55} = 66 \text{ Nm}$$

3 SELECT GEARED MOTOR

Refer to selection table one motor size larger than absorbed power.

Absorbed power = 0.38kW, therefore refer to 0.55kW selection table, page 32

Always select from 4 POLE selection table in the first instance as this offers a more economical solution.

Required output speed of gearbox = 55 rev/min

0.55 kW	N2 R/MIN	i	M2 Nm	Fm	N	UNIT DESIGNATION	Kg			
	Output Speed	Ratio	Output Torque	Service Factor	Overhung Load	Column Entry 1 Through 20 Spaces to be filled when entering order	Weight of Base Mount Unit	Motor Frame Size	Cone Ring Output Coupling Spaces to be filled when entering order	Max Bore Coupling Drive Half
4 POLE	261	5.25	17	2.61	2764	A 0 4 1 0 5 . 0 _ M _ . . . 5 5 4 A _	19.4	80a	X 6 1 2 0 1 M 0 2 0 -	38
	187	7.33	24	2.30	2764	7 . 5				
	130	10.50	33	2.27	2764	1 0 .				
	110	12.50	38	2.10	2758	1 3 .				
	94	14.50	44	2.01	2758	1 5 .				
	70	19.50	57	1.53	2748	2 0 .				
	55	25.00	66	1.51	2748	2 5 .				
	46	30.00	76	1.33	2742	3 0 .				
	34	40.00	94	0.99	2730	4 0 .				

Go to point 4

SELECTION PROCEDURE FOR MOTORISED UNITS

4 CHECK OUTPUT TORQUE

Output torque (M2) of selected unit must be equal or more than required output torque at gearbox outputshaft.

Required output torque at gearbox outputshaft = 66 Nm

0.55 kW	N2 R/MIN	i	M2 Nm	Fm	N	UNIT DESIGNATION	Kg	Cone Ring Output Coupling	Max Bore Coupling Drive Half				
	Output Speed	Ratio	Output Torque	Service Factor	Overhung Load								
4 POLE	261	5.25	17	2.61	2764	A 0 4 1 0 5 . 0 _ M _ - _ _ . 5 5 4 A _	19.4	80a	X 6 1 2 0 1 M 0 2 0 - _ _ _				
	187	7.33	24	2.30	2764	7 . 5							
	130	10.50	33	2.27	2764	1 0 .							
	110	12.50	38	2.10	2758	1 3 .							
	94	14.50	44	2.01	2758	1 5 .							
	70	19.50	57	1.53	2748	2 0 .							
	55	25.00	66	1.51	2748	2 5 .							
	46	30.00	76	1.33	2742	3 0 .							
	34	40.00	94	0.99	2730	4 0 .							
	Column Entry <input type="text" value="1"/> Through <input type="text" value="20"/> Spaces to be filled when entering order												
	Weight of Base Mount Unit												
Motor Frame Size													
Spaces to be filled when entering order													

Selected unit's output torque (M2) = 66 Nm, therefore unit is acceptable

5 CHECK SERVICE FACTOR

Service factor (Fm) of selected unit must be equal or more than required service factor.

Required service factor of gearbox = 1.25

0.55 kW	N2 R/MIN	i	M2 Nm	Fm	N	UNIT DESIGNATION	Kg	Cone Ring Output Coupling	Max Bore Coupling Drive Half				
	Output Speed	Ratio	Output Torque	Service Factor	Overhung Load								
4 POLE	261	5.25	17	2.61	2764	A 0 4 1 0 5 . 0 _ M _ - _ _ . 5 5 4 A _	19.4	80a	X 6 1 2 0 1 M 0 2 0 - _ _ _				
	187	7.33	24	2.30	2764	7 . 5							
	130	10.50	33	2.27	2764	1 0 .							
	110	12.50	38	2.10	2758	1 3 .							
	94	14.50	44	2.01	2758	1 5 .							
	70	19.50	57	1.53	2748	2 0 .							
	55	25.00	66	1.51	2748	2 5 .							
	46	30.00	76	1.33	2742	3 0 .							
	34	40.00	94	0.99	2730	4 0 .							
	Column Entry <input type="text" value="1"/> Through <input type="text" value="20"/> Spaces to be filled when entering order												
	Weight of Base Mount Unit												
Motor Frame Size													
Spaces to be filled when entering order													

Selected unit's service factor (Fm) = 1.51, therefore unit is acceptable.

6 CHECK OVERHUNG LOADS

If sprocket, gear, etc is mounted on the outputshaft then refer to Overhung Loads Procedure, page 48, and compare with allowable overhung load (N) of selected unit

Allowable overhung load (N) must be equal or more than calculated overhung load (P)

15 kW	N2 R/MIN	i	M2 Nm	Fm	N	UNIT DESIGNATION	Kg	Cone Ring Output Coupling	Max Bore Coupling Drive Half				
	Output Speed	Ratio	Output Torque	Service Factor	Overhung Load								
4 POLE	261	5.25	17	2.61	2764	A 0 4 1 0 5 . 0 _ M _ - _ _ . 5 5 4 A _	19.4	80a	X 6 1 2 0 1 M 0 2 0 - _ _ _				
	187	7.33	24	2.30	2764	7 . 5							
	130	10.50	33	2.27	2764	1 0 .							
	110	12.50	38	2.10	2758	1 3 .							
	94	14.50	44	2.01	2758	1 5 .							
	70	19.50	57	1.53	2748	2 0 .							
	55	25.00	66	1.51	2748	2 5 .							
	46	30.00	76	1.33	2742	3 0 .							
	34	40.00	94	0.99	2730	4 0 .							
	Column Entry <input type="text" value="1"/> Through <input type="text" value="20"/> Spaces to be filled when entering order												
	Weight of Base Mount Unit												
Motor Frame Size													
Spaces to be filled when entering order													

NOTE: If any of the following conditions occur then consult Application Engineering:-

- a) Inertia of the Driven Machine (Referred to motor speed) >10 Inertia of Gear Unit plus Motor b) Ambient temperature is above 40°C or c) Sizes A0730 and A0806 are required without a fan

SERIES AJ

SELECTION PROCEDURE FOR REDUCER UNITS

EXAMPLE APPLICATION DETAILS

Absorbed power of driven machine = 0.28kW
 Output speed of gearbox or Input speed of machine = 20rev/min
 Application = Uniformly loaded belt conveyor
 Duration of service (hours per day) = 24hrs
 Motor speed = 3 phase electric motor, 4 pole, 1450rpm
 Mounting position = D
 Ambient temperature = 20°C
 Running time (%) = 100%

1 DETERMINE MECHANICAL SERVICE FACTOR (Fm)

$$\frac{\text{Motor speed}}{\text{Gearbox output speed}} = \frac{1450}{20} = 72$$

Refer to exact ratios (page 17) for nearest standard ratio = 70:1

2 DETERMINE MECHANICAL SERVICE FACTOR (Fm)

Refer to Load Classification by Application, table 5, page 7
 Application = Uniformly loaded belt conveyor

Conveyors-uniformly loaded or fed		U = Uniform load
apron	U	
assembly	U	
belt	U	
bucket	U	
chain	U	

Refer to mechanical service factor (Fm), table 1, page 6
 Duration of service (hours per day) = 24hrs

Prime mover	Duration of service-hrs per day	Load classification-drive	
		Uniform	Moderate Shock
Electric motor, steam turbine or hydraulic motor	Under 3	0.80	1.00
	3 to 10	1.00	1.25
	Over 10	1.25	1.50

Therefore mechanical service factor (Fm) = 1.25

3 DETERMINE REQUIRED MECHANICAL OUTPUT TORQUE CAPACITY OF GEARBOX

$$\text{Absorbed output torque} = \frac{\text{Absorbed power} \times 9550}{\text{Gearbox output speed}}$$

$$\frac{0.28 \times 9550}{20} = 134 \text{ Nm}$$

$$\text{Required mechanical output torque} = \text{Absorbed output torque} \times F_m$$

$$134 \times 1.25 = 167 \text{ Nm}$$

4 DETERMINE SIZE OF GEAR BOX REQUIRED

Refer to ratings tables, Input speed = 1450rev/min, therefore refer to page 56.

NOMINAL RATIO	NOMINAL OUTPUT SPEED REV / MIN	CAPACITY		SIZE OF UNIT				
				A0510	A0610	A0730	A0860	
70.0	20.71	Mechanical	Input Power kW	0.35	0.58	0.86	1.35	
			Output Torque Nm	86.	147.	247.	402.	
		Thermal	Input Power kW	0.58	0.77	1.48	1.76	
			Output Torque Nm	149.	199.	442.	533.	
				Efficiency %	53	55	62	65

Mechanical output torque capacity must be equal or more than required mechanical output torque capacity of gear box. Required mechanical output torque capacity = 167Nm. At a 70:1 ratio, nominal output speed 20.71 an A0730 unit has a mechanical output torque capacity of 247Nm. Therefore the unit is acceptable

5 DETERMINE EXACT RATIO OF GEAR BOX

Refer to exact ratio table, page 17.

Nominal Ratio Column Entry	A0510	A0610	A0730	A0860
6 7 8				
7 0 .	70	70	70	70

Exact ratio = 70.0:1

4 CHECK THERMAL CAPACITY OF GEAR BOX SELECTED DETERMINE THERMAL OUTPUT TORQUE CAPACITY (Tt)

Refer to ratings tables

NOMINAL RATIO	NOMINAL OUTPUT SPEED REV / MIN	CAPACITY		SIZE OF UNIT				
				A0510	A0610	A0730	A0860	
70.0	20.71	Mechanical	Input Power kW	0.35	0.58	0.86	1.35	
			Output Torque Nm	86.	147.	247.	402.	
		Thermal	Input Power kW	0.58	0.77	1.48	1.76	
			Output Torque Nm	149.	199.	442.	533.	
				Efficiency %	53	55	62	65

Tt = 442Nm

Go to point 7

SELECTION PROCEDURE FOR REDUCER UNITS

7 DETERMINE THERMAL SERVICE FACTOR (Ft)

Refer to table 2, page 6
Ambient temperature = 20°C

Ambient temperature°C	-30	-20	-10	0	10	20
Factor Ft	1.65	1.52	1.39	1.26	1.14	1.0
Ft =	1.0					

8 DETERMINE THERMAL SERVICE FACTOR (Fp)

Refer to table 3, page 6
Mounting position = D
Nominal output speed (rev/min) = 20.71

Unit Output Shaft Speed (Rev/min)	Mounting	
	ABC	DEF
0 to 100	1.0	1.0
>100 to 200	1.0	1.0
>200 to 300	1.0	1.0

Fp = 1.0

9 DETERMINE THERMAL SERVICE FACTOR (Fd)

Refer to table 4, page 6
% running time = 100

Input shaft speed (Rev/min)	Unit Size	% Running time per hour	
		>60	>50-60
	280-610	1.0	1.46
1450	730	1.0	1.28
	860	1.0	1.34

Fd = 1.0

10 DETERMINE ALLOWABLE OUTPUT TORQUE THERMAL RATING (T_{therm})

$$T_{therm} = T_t \times F_t \times F_p \times F_d$$

$$= 442 \times 1.0 \times 1.0 \times 1.0$$

$$= 442 \text{ Nm}$$

Thermal output torque capacity (T_{therm}) must be equal or more than absorbed output torque to drive machine
Absorbed output torque = 134Nm (see step 3) T_{therm} = 442Nm

Therefore unit is acceptable

11 DETERMINE REQUIRED POWER OF ELECTRIC MOTOR

Refer to ratings tables to determine gear unit efficiency.

NOMINAL RATIO	NOMINAL OUTPUT SPEED REV / MIN	CAPACITY		SIZE OF UNIT			
				A0510	A0610	A0730	A0860
70.0	20.71	Mechanical	Input Power kW	0.35	0.58	0.86	1.35
			Output Torque Nm	86.	147.	247.	402.
		Thermal	Input Power kW	0.58	0.77	1.48	1.76
			Output Torque Nm	149.	199.	442.	533.
		Efficiency %		53	55	62	65

$$\text{Efficiency \%} = 62 \quad \text{Required motor power} = \frac{\text{Absorbed power of driven machine} \times 100}{\text{Efficiency}} = \frac{28 \times 100}{62} = 45\text{kW}$$

The next largest standard motor power available is selected 0.55kW

12 CHECK MOMENTARY OVERLOAD CAPACITY

Convert nominal motor capacity (kW) to torque (Nm) at gearbox output shaft

$$\text{Nominal output torque} = \frac{\text{Nominal motor capacity} \times 9550}{\text{Output speed of gearbox} \times 100} = \frac{.55 \times 9550 \times 62}{20 \times 100} = 163\text{Nm}$$

Refer to ratings tables to determine gear unit efficiency

kW COLUMN ENTRY	MOTOR FRAME SIZE	FULL LOAD SPEED	FLC (AMPS) 400 VOLTS	EFFICIENCY %			POWER FACTOR			D.O.L. STARTING % OF FULL LOAD		STAR DELTA STARTING % OF FULL LOAD		PULL UP TORQUE % FLT
				FL	3/4 L	1/2 L	FL	3/4 L	LRT	LRC	LRT	LRC	LRT	
15 5	16 5	17 5	71	2720	1.5	68	66	62	0.80	0.73	0.63	LRC	LRT	260
			80	1370	1.6	67.5	68	65	0.74	0.64	0.52	250	400	180
			80	925	1.65	67	62	53	0.72	0.62	0.52	250	370	200

$$\text{Maximum motor starting torque} = \text{Pull up torque} \times \text{Normal output torque} = 1.8 \times 163 = 293\text{Nm}$$

Gearbox will accept 2 x Momentary overload (10 times / day maximum)

$$\text{Peak allowable torque} = 2 \times \text{mechanical gearbox rating (see step 4)} = 2 \times 247 = 494\text{Nm}$$

Maximum motor starting torque must be equal or less than peak allowable torque

$$\text{Peak allowable torque} = 494\text{Nm}$$

$$\text{Maximum motor starting torque} = 293\text{Nm}$$

Therefore the unit is acceptable

13 CHECK OVERHUNG LOADS

If sprocket, gear, etc is mounted on the input or output shaft then refer to Overhung loads procedure, pages 48 & 49

NOTE: If any of the following conditions occur then consult our Application Engineers:-

- a) Inertia of the driven Machine (referred to motor speed) >10
- b) Ambient temperature is above 40°C
- c) Sizes A0730 and A0860 are required without a fan

SERIES AJ

HANDING & MOUNTING POSITIONS

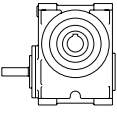
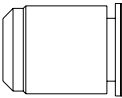
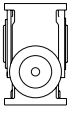
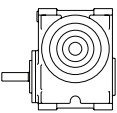
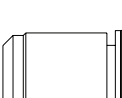
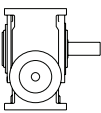
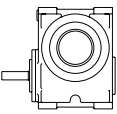
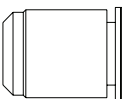
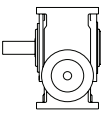
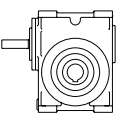
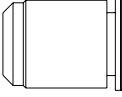
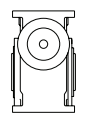
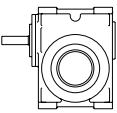
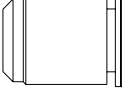
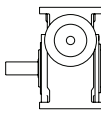
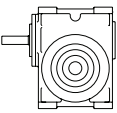
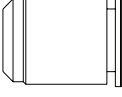
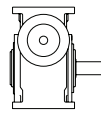
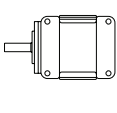
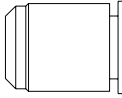
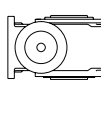
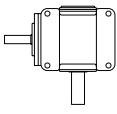
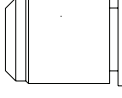
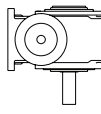
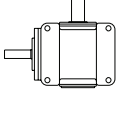
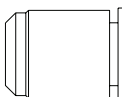
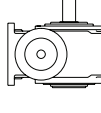
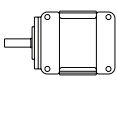
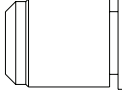
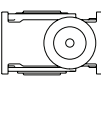
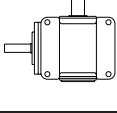
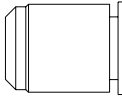
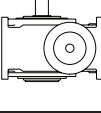
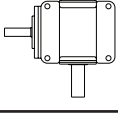
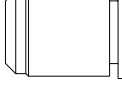
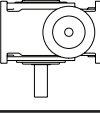
COLUMN 13 ENTRY	DOUBLE OUTPUT SHAFTS ARE AVAILABLE FOR ALL MOUNTING POSITIONS		
A			
B			
C			
D			
E			
F			
G			
H			
J			
K			
M			
N			

SERIES AJ

HANDING & MOUNTING POSITIONS

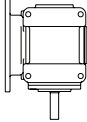
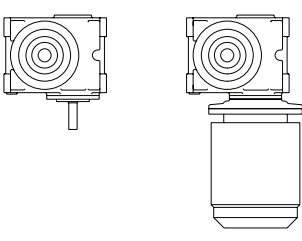
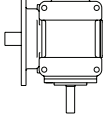
COLUMN 13 ENTRY	DOUBLE OUTPUT SHAFTS ARE AVAILABLE FOR ALL MOUNTING POSITIONS		
<div style="border: 1px solid black; width: 20px; height: 20px; display: flex; align-items: center; justify-content: center; margin: 0 auto;">P</div>			
<div style="border: 1px solid black; width: 20px; height: 20px; display: flex; align-items: center; justify-content: center; margin: 0 auto;">S</div>			
<div style="border: 1px solid black; width: 20px; height: 20px; display: flex; align-items: center; justify-content: center; margin: 0 auto;">T</div>			
<div style="border: 1px solid black; width: 20px; height: 20px; display: flex; align-items: center; justify-content: center; margin: 0 auto;">H</div>			
<div style="border: 1px solid black; width: 20px; height: 20px; display: flex; align-items: center; justify-content: center; margin: 0 auto;">X</div>			
<div style="border: 1px solid black; width: 20px; height: 20px; display: flex; align-items: center; justify-content: center; margin: 0 auto;">Y</div>			

PRIMARY UNIT MOUNTING POSITIONS

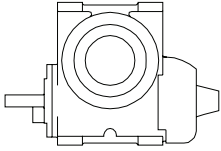
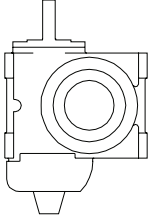
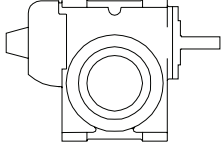
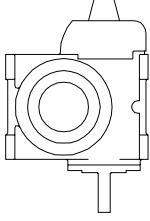
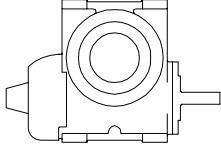
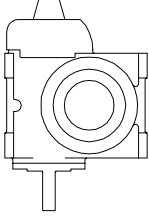
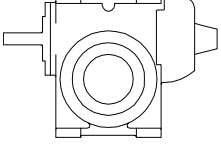
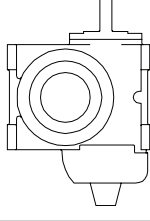
COLUMN 14 ENTRY		COLUMN 14 ENTRY	
1		2	
3		4	
5		6	
7		8	

PRIMARY UNIT POSITION RELATIVE TO THE SECONDARY UNIT

FOR SINGLE REDUCTION ENTER



EXACT RATIOS

Single Reduction

NOMINAL RATIO COLUMN ENTRY	A0280	A0410	A0510	A0610	A0730	A0860
5 . 0	5.250	5.250	4.800	5.000	5.200	4.833
7 . 0	7.333	7.333	7.333	7.333	7.250	7.250
1 0 .	10.50	10.50	10.50	9.667	10.33	9.667
1 2 .	12.50	12.50	12.50	12.50	12.50	12.67
1 5 .	14.50	14.50	14.50	15.00	14.50	14.50
2 0 .	20.00	19.50	20.00	20.00	19.50	19.50
2 5 .	25.00	25.00	25.00	25.00	25.00	25.00
3 0 .	30.00	30.00	30.00	30.00	30.00	30.00
4 0 .	40.00	40.00	40.00	40.00	40.00	40.00
5 0 .	50.00	50.00	50.00	50.00	50.00	50.00
6 0 .	60.00	60.00	60.00	60.00	60.00	60.00
7 0 .	70.00	70.00	70.00	70.00	70.00	70.00

Double Reduction

NOMINAL RATIO	COLUMN ENTRY			A0410	A0510	A0610	A0730	A0860
	6	7	8					
75.00	7	5	.	76.13	76.13	78.75	76.13	69.60
100.00	1	0	0	102.4	105.0	105.0	102.4	93.60
125.00	1	2	5	131.3	131.3	131.3	131.3	120.0
150.00	1	5	0	152.3	152.3	157.5	152.3	152.3
200.00	2	0	0	204.8	210.0	210.0	204.8	204.8
225.00	2	2	5	210.3	210.3	217.5	210.3	210.3
250.00	2	5	0	262.5	262.5	262.5	262.5	262.5
300.00	3	0	0	290.0	290.0	292.5	282.8	290.0
350.00	3	5	0	362.5	362.5	362.5	362.5	336.0
375.00	3	7	5	367.5	367.5	367.5	367.5	362.5
400.00	4	0	0	390.0	400.0	390.0	380.3	390.0
450.00	4	5	0	435.0	435.0	435.0	435.0	435.0
500.00	5	0	0	500.0	500.0	487.5	487.5	500.0
600.00	6	0	0	600.0	600.0	585.0	585.0	600.0
625.00	6	2	5	625.0	625.0	625.0	625.0	625.0
700.00	7	0	0	735.0	735.0	676.7	723.3	676.7
750.00	7	5	0	750.0	750.0	750.0	750.0	750.0
800.00	8	0	0	780.0	800.0	800.0	780.0	780.0
900.00	9	0	0	900.0	900.0	900.0	900.0	900.0
1000.00	1	0	C	1000.	1000.	1000.	1000.	1000.
1200.00	1	2	C	1200.	1200.	1200.	1200.	1200.
1250.00	1	3	C	1250.	1250.	1250.	1250.	1250.
1400.00	1	4	C	1365.	1400.	1400.	1365.	1365.
1500.00	1	5	C	1500.	1500.	1500.	1500.	1500.
1600.00	1	6	C	1600.	1600.	1600.	1600.	1600.
1750.00	1	7	C	1750.	1750.	1750.	1750.	1750.
1800.00	1	8	C	1800.	1800.	1800.	1800.	1800.
2000.00	2	0	C	2000.	2000.	2000.	2000.	2000.
2100.00	2	1	C	2100.	2100.	2100.	2100.	2100.
2400.00	2	4	C	2400.	2400.	2400.	2400.	2400.
2500.00	2	5	C	2500.	2500.	2500.	2500.	2500.
2800.00	2	8	C	2800.	2800.	2800.	2800.	2800.
3000.00	3	0	C	3000.	3000.	3000.	3000.	3000.
3500.00	3	5	C	3500.	3500.	3500.	3500.	3500.
3600.00	3	6	C	3600.	3600.	3600.	3600.	3600.
4200.00	4	2	C	4200.	4200.	4200.	4200.	4200.

OUTPUT OPTIONS

OUTPUT SHAFT OPTIONS. COLUMN 11 ENTRY

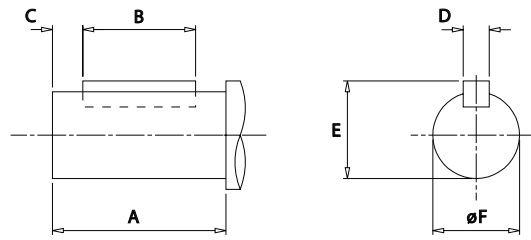

SIZE OF UNIT	TYPE OF OUTPUTSHAFT	COLUMN 11 ENTRY		DIMENSIONS IN MM (INCH SHAFTS IN INCHES)					
		SINGLE EXT	DOUBLE EXT	A	B	C	D	E	øF
A0280	Standard	C	D	35	23	5.5	5.000 4.970	18.00 17.87	16.012 16.001
	Inch	N	P	1.25"	0.9375"	0.16"	0.190" 0.188"	0.707" 0.699"	0.6250" 0.6245"
A0410	Standard	C	D	45	34	6	6.000 5.970	22.50 22.37	20.015 20.002
	Inch	N	P	1.625"	1.3125"	0.16"	0.190" 0.188"	0.834" 0.826"	0.7500" 0.7495"
A0510	Standard	C	D	57	42	7	8.000 7.964	28.00 27.71	25.015 25.002
	Inch	N	P	2.125"	1.7500"	0.19"	0.252" 0.250"	1.110" 1.102"	1.0000" 0.9995"
A0610	Standard	C	D	70	55	7	8.000 7.964	31.00 30.71	28.015 28.002
	Inch	N	P	2.625"	2.0000"	0.25"	0.252" 0.250"	1.238" 1.230"	1.1250" 1.1245"
A0730	Standard	C	D	83	62	7	8.000 7.964	33.00 32.71	30.015 30.002"
	Inch	N	P	3.25"	2.5000"	0.25"	0.252" 0.250"	1.364" 1.356"	1.2500" 1.2495"
A0860	Standard	C	D	98	80	8	10.000 9.964	38.00 37.71	35.018 35.002
	Inch	N	P	3.875"	3.2500"	0.31"	0.377" 0.375"	1.666" 1.658"	1.5000" 1.4995"

OUTPUT BORE OPTIONS. COLUMN 11 ENTRY

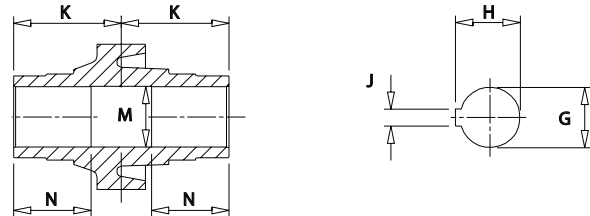

SIZE OF UNIT	TYPE OF OUTPUTBORE	COLUMN 11 ENTRY	DIMENSIONS IN MM (INCH BORE IN INCHES)					
			G	H	J	K	M	N
A0280	Standard	H	16.034 16.016	18.4 18.3	5.015 4.985	40	16.3 16.2	32
	Inch	A	0.6257" 0.6250"	0.715" 0.709"	0.1895" 0.1875"	1.575"	0.635" 0.630"	1.26"
A0410	Standard	H	22.041 22.020	24.9 24.8	6.015 5.985	50	22.3 22.2	40
	Inch	A	0.7508" 0.7500"	0.843" 0.837"	0.1895" 0.1875"	1.969"	0.760" 0.755"	1.57"
A0510	Standard	H	25.041 25.020	28.5 28.3	8.018 7.982	56	25.3 25.2	45
	Inch	A	1.0008" 1.0000"	1.120" 1.114"	0.252" 0.250"	2.205"	1.010" 1.005"	1.77"
A0610	Standard	H	35.050 35.025	38.5 38.3	10.018 9.982	64	35.3 35.2	50
	Inch	A	1.3760" 1.3750"	1.524" 1.518"	0.3145" 0.3125"	2.520"	1.385" 1.380"	1.97"
A0730	Standard	H	40.050 40.025	43.5 43.3	12.021 11.979	77	40.3 40.2	60
	Inch	A	1.6260" 1.6250"	1.802" 1.796"	0.377" 0.375"	3.031"	1.635" 1.630"	2.36"
A0860	Standard	H	50.050 50.025	54.0 53.8	14.021 13.979	93	50.3 50.2	73
	Inch	A	1.8760" 1.8750"	2.102" 2.096"	0.502" 0.500"	3.661"	1.885" 1.880"	2.87"

MOTOR ADAPTORS IEC & NEMA ADDITIONAL FEATURES

IEC MOTOR ADAPTORS, COLUMN 12 ENTRY FOR G TYPE ONLY

MOTOR FRAME/ FLANGE	UNIT SIZE					
	A0280	A0410	A0510	A0610	A0730	A0860
63/D	A	-	-	-	-	-
71/D	B	B	B	-	-	-
71/C	C	C	C	-	-	-
80/D	-	D	D	D	D	-
80/C	-	E	E	E	-	-
90/D	-	-	F	F	F	F
90/C	-	-	G	G	G	-
100/112D	-	-	-	H	H	H
100/112C	-	-	-	J	J	J
132/D	-	-	-	-	-	K
132/C	-	-	-	-	-	L

NEMA MOTOR ADAPTORS, COLUMN 12 ENTRY FOR A TYPE ONLY

MOTOR FRAME/ FLANGE	UNIT SIZE					
	A0280	A0410	A0510	A0610	A0730	A0860
56C	T	T	T	T	-	-
143TC / 145TC	-	V	V	V	V	V
182TC / 184TC	-	-	-	X	X	X
213TC / 215TC	-	-	-	-	-	Y

ADDITIONAL FEATURES - COLUMN 20 ENTRY

COLUMN 20 ENTRY	SPIGOT CASE	PRIME PAINTED ONLY	LUBRICANT TYPE	
			MINERAL	SYNTHETIC
-			•	
B		•	•	
H				
K		•		
R				•
T		•		•
2	•		•	
3	•	•	•	
4	•			
5	•	•		
6	•			•
7	•	•		•

SERIES AJ

CONE RING FLEXIBLE COUPLINGS

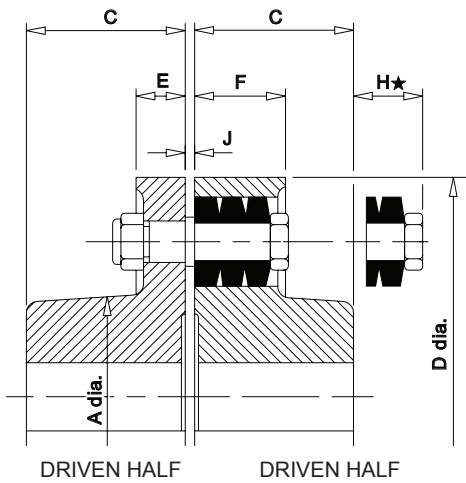

This type of coupling compensates for normal angular and parallel misalignment of shafts, together with a limited freedom of axial movement. The conical section rubber rings provide greatly improved torsional flexibility in drives where shock or cyclic loadings are present.

Two types are available, MEDIUM DUTY and HEAVY DUTY. Medium duty couplings (types 612 and 614) are identical to heavy duty couplings (types 611 and 613) except that they are supplied with only half the standard number of pin and ring assemblies. This enables a useful cost saving to be made when the size of coupling is determined by the shaft diameter rather than the coupling's torque capacity.

Parallel Keyway to BS 4235 : Part 1 1972 (1986) with P9 width tolerance

Bore tolerance to ISO 286-2-1988(E) is M7 upto and incl. 50 mm
K7 over 50 mm

Coupling Size	A	D	E	F	H	H★	J
01	64	134	12	26	20	28	3
02	70	147	12	26	12	23	3
03	83	171	19	35	26	37	3
04	97	193	19	35	19	37	3
05	117	215	19	35	11	37	3
06	127	254	31	56	46	59	3
07	147	279	31	56	34	52	3

Reference Number	Bore Diameter	Reference Number	Bore Diameter
035	35	---	Pilot
038	38	018	18
040	40	019	19
042	42	020	20
045	45	022	22
048	48	024	24
050	50	025	25
055	55	028	28
056	56	030	30
060	60	032	32

★ The coupling pin withdrawal distance is dimension H for straight bored couplings or dimension H★ for taper bushed couplings.

Coupling size	Types 611 & 612 Straight bored				Types 613 & 614 Taper bushed				Types 612 & 614 Medium Duty				Types 611 & 613 Heavy Duty		
	Max. bore	Min. bore		Hub length C	Max. bore	Min. bore	Hub length C	Taper bush length	Torque kNm	kW 100 rev/min	kW 960 rev/min	kW 1450 rev/min	Torque kNm	kW 100 rev/min	Max rev/min
	Driving half	Driven half													
01	38	*	19	48	25	9	40	22.3	0.090	0.95	9.1	13.7	0.181	1.89	4780
02	42	*	22	56	32	11	45	38.1	0.140	1.46	14.0	21.2	0.279	2.92	4335
03	48	*	25	61	40	14	50	38.1	0.232	2.43	23.4	35.3	0.465	4.87	3745
04	60	*	28	68	48	18	50	44.5	0.359	3.75	36.0	54.4	0.717	7.51	3320
05	70	*	32	76	60	16	50	44.5	0.509	5.33	51.2	77.3	1.018	10.7	3000
06	80	25	42	88	60	19	75	63.5	1.219	12.76	123	185	2.438	25.5	2520
07	90	30	55	100	75	35	82	76.2	1.681	17.60	169	255	3.362	35.2	2295

* Note: up to size 05 the Driving half hubs are solid.

All dimensions in mm

For applications in ambient temperatures above 80°C (176°F) or below -30°C (-22°F) refer to our Application Engineers.

The depths of rectangular Imperial keyways to BS46 are generally greater than the equivalent metric keyways, hence the maximum bores given must be marginally reduced when using an Imperial inch system. Consult our Application Engineers for details.

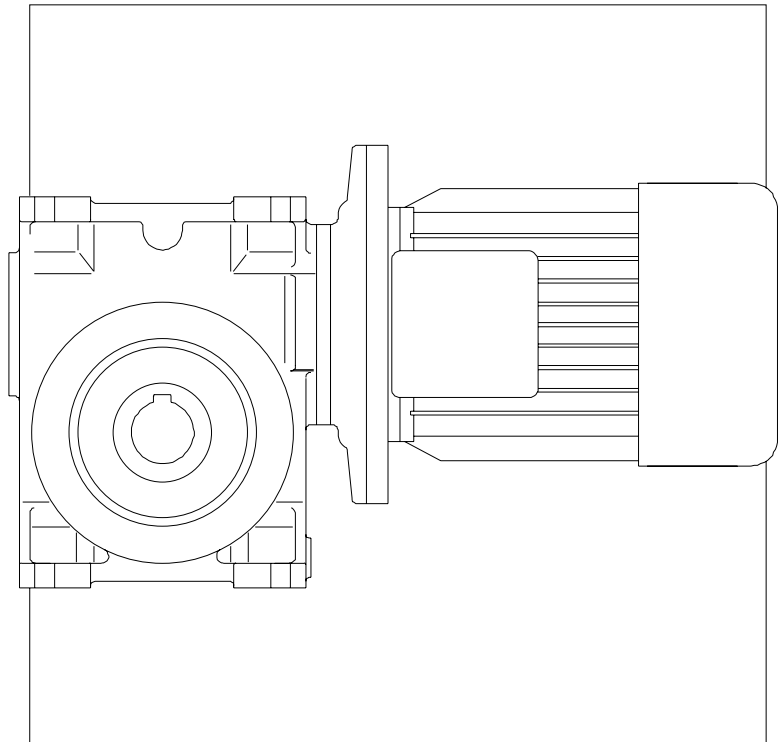

MOTORISED
SERIES AJ

MOTOR PERFORMANCE DATA ALUMINIUM FRAME MOTORS

Type Cage Rotor
 Enclosure IP55, TEV (ICO141)
 Rating S1 (Maximum Continuous)
 Supply 3 PH 50Hz 380 - 415V
 Insulation Class F
 Temp. Rise Class B

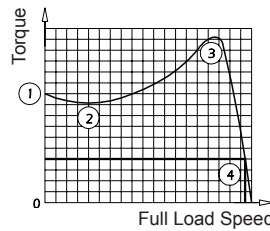

Typical Speed/Torque Curve (D.O.L. Starting)

- (1) Starting Torque or Locked Rotor Torque
- (2) Pull Up Torque or Run Up Torque
- (3) Pull Out Torque or Breakdown Torque
- (4) Full Load Torque

Torque/Speed curves for specific motors can be supplied on request

kW COLUMN ENTRY	MOTOR FRAME SIZE	FULL LOAD SPEED	FLC (AMPS) 400 VOLTS	EFFICIENCY %			POWER FACTOR			D.O.L. STARTING % OF FULL LOAD		STAR DELTA STARTING % OF FULL LOAD		PULL UP TORQUE % FL	PULL OUT TORQUE % FL	ROTOR INERTIA WK2 IN KGM ²
				FL	% L	½ L	FL	% L	½ L	LRT	LRC	LRT	LRC			
. 1 2	63	1360	0.5	55	50	43	0.65	0.60	0.50	260	320			240	260	0.00025
	63	835	0.6	43	41	37	0.62	0.56	0.46	230	250			200	180	0.0003
	71	600	0.7	42	38	34	0.56	0.50	0.42	200	250			180	180	0.0006
. 1 8	63	2680	0.54	61	58	52	0.79	0.73	0.60	250	380			210	210	0.0002
	63	1360	0.7	56	52	44	0.67	0.60	0.50	260	320			240	260	0.0003
	71	840	0.8	52.5	51	47	0.62	0.55	0.47	230	260			200	180	0.0005
	80	650	0.8	53	49	45	0.61	0.56	0.45	180	230			160	180	0.0024
. 2 5	63	2730	0.7	64	61	55	0.80	0.72	0.60	240	400			210	210	0.00023
	71	1370	0.8	64	60	54	0.68	0.63	0.56	270	370			240	260	0.0005
	71	845	1.1	53	52.5	50	0.62	0.55	0.47	240	280			200	180	0.0006
. 3 7	80	650	1.0	55.5	52	46	0.68	0.60	0.50	180	250			160	180	0.00275
	71	2730	1.05	65	62	58	0.79	0.72	0.60	280	400			250	250	0.0004
	71	1380	1.2	65	64	58	0.67	0.60	0.52	280	420			260	270	0.0006
	80	925	1.2	62	59	50	0.72	0.62	0.52	220	340			170	200	0.0024
. 5 5	90	680	1.4	62	59	53	0.62	0.54	0.44	260	380			220	230	0.00375
	71	2720	1.5	68	66	62	0.80	0.73	0.63	280	420			260	250	0.00045
	80	1370	1.6	67.5	68	65	0.74	0.64	0.52	250	400			180	200	0.0013
	80	925	1.65	67	62	53	0.72	0.62	0.52	250	370			200	210	0.00275
. 7 5	90	690	2.05	63	60	54	0.62	0.54	0.44	320	420			270	280	0.005
	80	2800	1.9	71	69	67	0.83	0.78	0.66	230	460			190	230	0.00083
	80	1385	2.2	70	69	66	0.72	0.62	0.51	250	430			190	200	0.0016
	90	910	2.2	67	65	63	0.75	0.66	0.55	240	360			190	240	0.00375
1 . 1	100	700	2.4	68	68	66	0.68	0.58	0.48	160	440			110	170	0.0093
	80	2840	2.5	76	75	73	0.83	0.75	0.64	250	540			190	240	0.00097
	90	1380	2.9	72	72.5	72	0.76	0.68	0.57	250	440			220	250	0.0033
	90	920	3.1	71	68	64	0.73	0.67	0.52	240	460			140	290	0.005
1 . 5	100	700	3.4	69	68	66	0.68	0.58	0.48	200	440			140	180	0.0123
	90	2820	3.5	76	75	74	0.82	0.73	0.63	240	500			200	250	0.0016
	90	1390	3.8	76	76	75	0.76	0.66	0.55	260	500			230	260	0.004
	100	950	3.9	75	74.5	73	0.75	0.66	0.54	180	500			150	200	0.01
2 . 2	112	700	4.3	72	72	70	0.71	0.62	0.52	180	430			170	200	0.017
	90	2850	5.0	78	78	77	0.82	0.73	0.63	300	700			260	320	0.0022
	100	1410	5.2	78.5	78.5	78	0.78	0.71	0.60	240	530			210	240	0.0073
	112	945	5.5	75	76	76	0.77	0.71	0.57	220	500			190	200	0.015
3 . 0	132	705	5.8	74	74	73.5	0.74	0.64	0.53	180	500			130	160	0.038
	100	2900	6.5	79	79	77	0.84	0.74	0.64	270	700			250	300	0.005
	100	1420	6.8	80	80	79	0.80	0.72	0.60	240	550			210	250	0.009
	132	950	7.1	78	78	77	0.78	0.71	0.60	190	600			150	200	0.03
4 . 0	132	710	7.6	76.5	77	76	0.75	0.68	0.56	180	430			130	160	0.046
	112	2900	8.2	83	83	82	0.85	0.81	0.73	280	700	85	220	260	300	0.0063
	112	1425	8.6	83	83	82	0.81	0.72	0.62	270	620	84	195	230	290	0.0115
5 . 5	132	955	9.5	78	78	77	0.78	0.72	0.62	230	600	73	190	160	230	0.038
	132	2900	11.8	83	82.5	80	0.82	0.75	0.64	340	700	100	220	280	280	0.016
	132	1450	11.85	85	85.5	85	0.79	0.72	0.59	260	650	80	200	180	270	0.0238
7 . 5	132	960	13	81	80	79	0.76	0.66	0.54	260	660	80	210	180	260	0.046
	132	2900	15.3	84.5	84	81	0.84	0.79	0.73	330	700	100	220	270	270	0.019
9 . 2	132	1450	15.6	86	86	85	0.81	0.75	0.64	260	690	80	215	180	270	0.03
	132	2910	18.5	85	85	83	0.85	0.81	0.73	340	720	105	220	270	270	0.023
1 1 .	132	1460	18.5	88	88	87	0.82	0.75	0.65	260	740	81	230	180	270	0.0338
	132	2920	22	89	89	88	0.82	0.77	0.68	210	620	70	200	200	270	0.03

All variants of standard IEC and NEMA motors can be fitted to Series A, single and double reduction gear units.

For example:-

- Single phase
- DC
- Energy efficient
- Wash down
- Explosion-proof
- Suitable to be used with inverters
- Force vented
- Flame proof
- Two speed
- Tropicalised
- Crane duty
- Underground specification
- Fitted with encoders
- Fitted with tacho
- Fitted with thermistors
- Fitted with anti condensation heaters
- Hydraulic motors with IEC flanges
- Air motors with IEC flanges

Standard clutch brake modules with IEC flanges can be fitted between motor and gearhead.

Variable speed packages are available, either belt variators or mechanical disc variators.

For any of these combinations please contact your local Sales office.

SERIES AJ

BRAKE MOTORS

MOTORS AVAILABLE

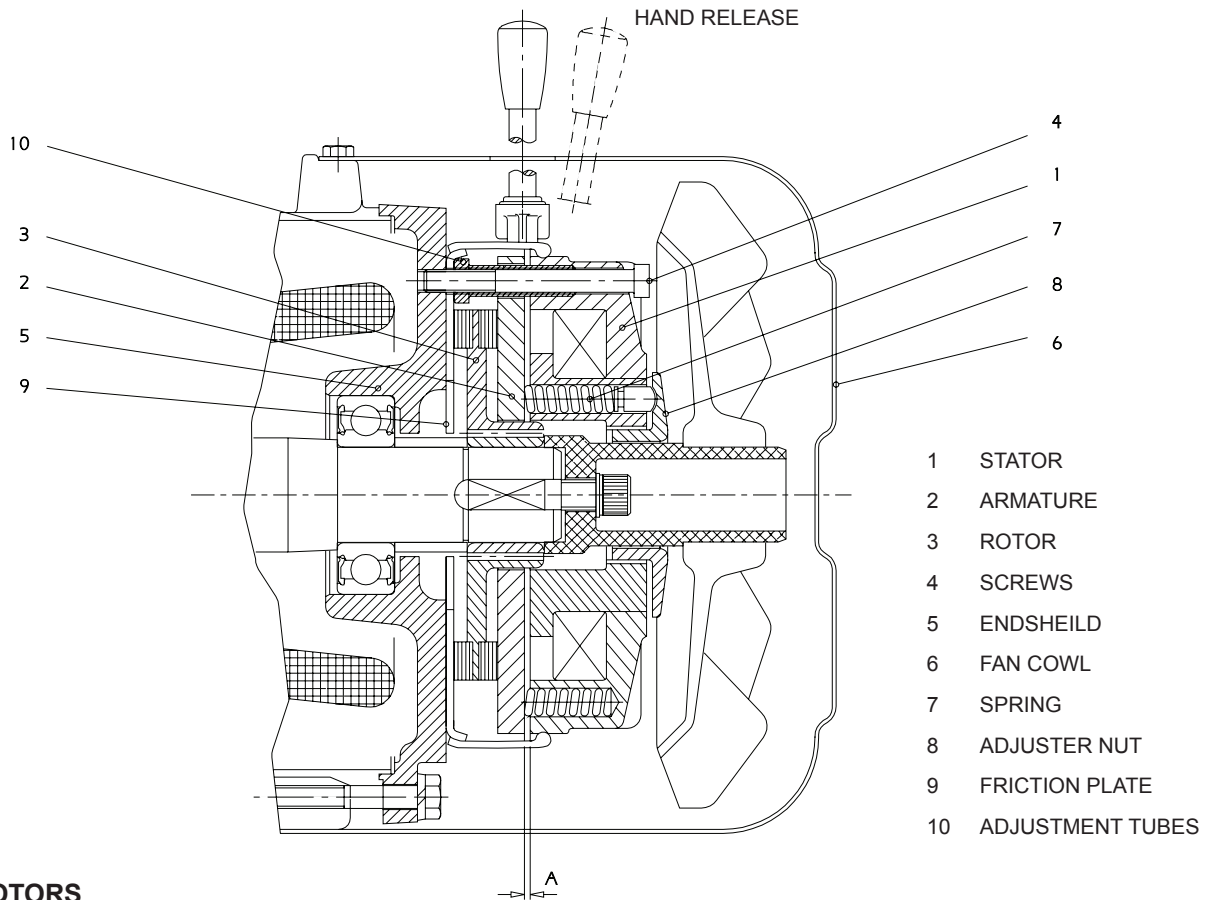

BRAKE MOTORS

Brake motors are fitted with spring-loaded brakes (mounted between motor endshield and fan blade) under the fan cowl. When the motor is switched on, the brake is supplied with DC voltage via a suitable rectifier.

The spring-loaded brake is normally off, electromagnetically released brake comprising the stator (1), the armature (2) and the brake rotor (3). It is fixed to the motor endshield (5) with screws (4) and located under the fan cowl (6). The friction plate (9) is held against the motor end shield (5) and serves as a counter friction face. When the release current does not flow the springs (7) press the armature (2) against the brake rotor (3) which in turn is pressed against the friction plate (9). The braking torque is generated through friction on both friction faces.

When switching on the motor the brake release coil is activated and the magnetic force of the stator (1) releases armature (2) against the spring resistance (7). The rotor (3) is freed.

The brake torque can be reduced by a maximum of 40% by using an adjuster (8).

We recommend to check the air gap A periodically, although, normally the brake needs no maintenance. Depending on the inertia to brake, speed, and switching frequency, the rotor can wear and become smaller due to the friction at the friction surfaces. If A max. (see table) is attained, the air gap must be adjusted. Where adjustment is needed, slacken screws (4) and reset the gap by turning adjustment tubes (10). Re-tighten screws (4) to the correct torque shown in the table below.

MOTOR FRAME SIZE		63	71	80	90	100/112	132
BRAKE SIZE		06	06	08	10	12	14
BRAKE TORQUE	Nm	2.85	4	8	16	32	60
A	mm	0.2	0.2	0.2	0.2	0.3	0.3
A max	mm	0.5	0.5	0.5	0.5	0.75	0.8
BOLT TIGHTENING TORQUE	Nm	3	3	6	10	10	25

MOTORS AVAILABLE
COLUMN 19 ENTRY

TYPE OF MOTOR	COLUMN 19 ENTRY
STANDARD	A
STANDARD WITH BRAKE	B
STANDARD WITH BRAKE & HAND RELEASE	C
FIT NON STANDARD MOTOR	N
FIT FREE ISSUE MOTOR	F

* The standard motor with brake will be fitted with a rectifier and wired for AC switching.

For fast braking needed with safety critical applications (ie lifts, hoists and cranes), it is essential to switch the brake on the DC side of the rectifier.

In such cases motor type N should be entered in column 19.

For larger frame sizes standard proprietary brake motors are available. For details contact our Application Engineers.

MOTOR DETAIL

B14 'C' FACE

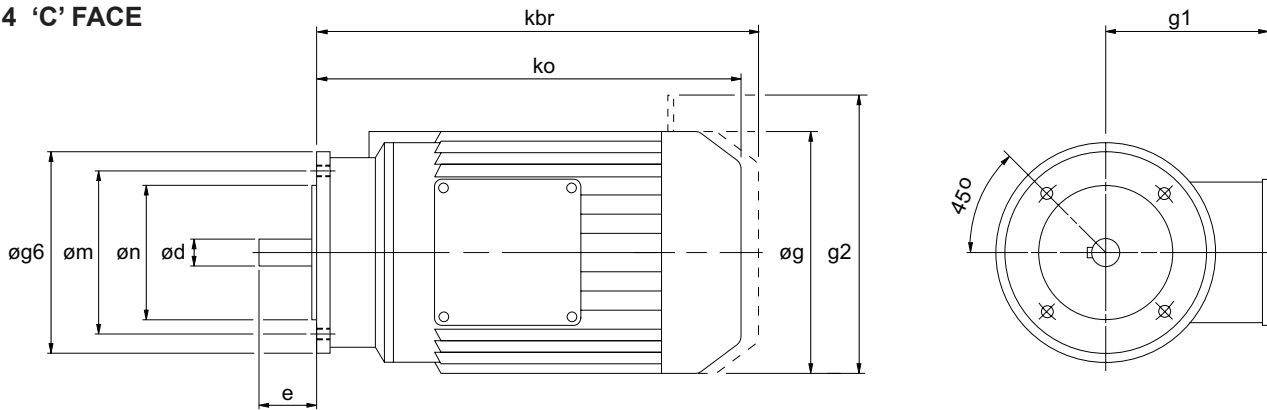

MOTOR FRAME SIZE	øg6	øm	øn	ød	e	ko	kbr	øg	g1	g2	FIXING BOLTS
71	105	85	70	14	30	210	251	137	107	167	4-M6
80	120	100	80	19	40	230	280	158	118	190	4-M6
90S/L	140	115	95	24	50	270	329	177	149	218	4-M8
100	160	130	110	28	60	340	408	197	159	238	4-M8
112	160	130	110	28	60	340	408	197	159	238	4-M8
132S/M	200	165	130	38	80	402	473	253	184	288	4-M10

B5 'D' FLANGE

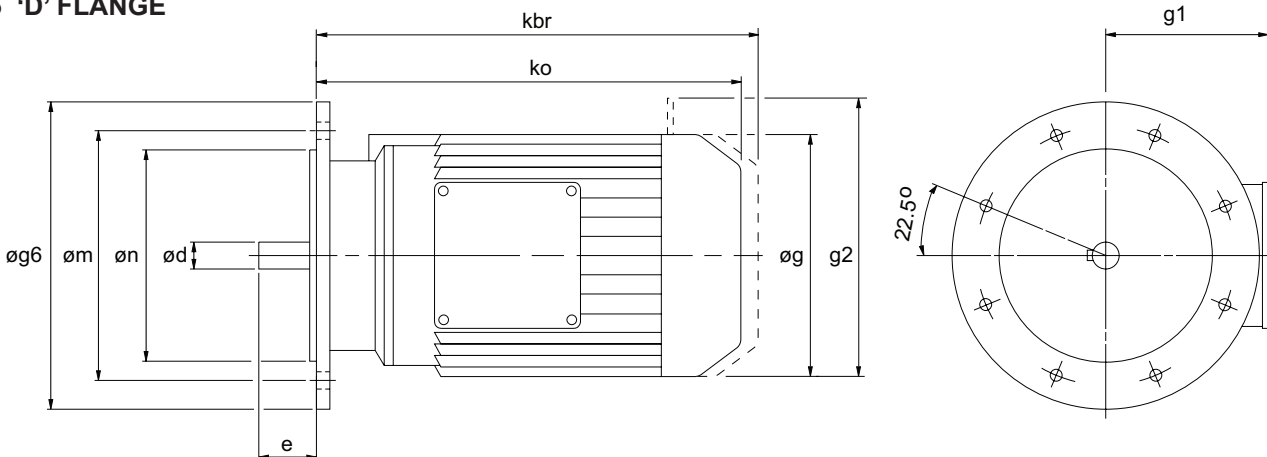

MOTOR FRAME SIZE	øg6	øm	øn	ød	e	ko	kbr	øg	g1	g2	FIXING BOLTS
63	140	115	95	11	23	185	227	122	101	160	4-M8
71	160	130	110	14	30	210	251	137	107	167	4-M8
80	200	165	130	19	40	230	280	158	118	190	4-M10
90S/L	200	165	130	24	50	270	329	177	149	218	4-M10
100	250	215	180	28	60	340	408	197	159	238	4-M12
112	250	215	180	28	60	340	408	197	159	238	4-M12
132S/M	300	265	230	38	80	402	473	253	184	288	4-M12

When fitting motor always use stepped key provided with gearbox, not the standard key supplied with motor

These dimensions apply to our standard motors

SERIES AJ

SELECTION TABLES GEARED MOTORS

0.09 kW

6 POLE

N2 R/MIN	i	M2 Nm	Fm	N	UNIT DESIGNATION	Kg			
Output Speed	Ratio	Output Torque	Service Factor	Overhung Load	Column Entry 1 Through 20 Spaces to be filled when entering order	Weight of Base Mount Unit	Motor Frame Size	Cone Ring Output Coupling Spaces to be filled when entering order	Max Bore Coupling Drive Half
160	5.25	4	5.12	1440	A 0 2 8 0 5 . 0 _ M _ - _ - . 0 9 6 A _	10.6	63a	X 6 1 2 0 1 M 0 1 6 - _ - _ -	38
115	7.33	6	4.60	1440	7 . 5				
80	10.50	8	4.15	1440	1 0 .				
67	12.50	9	3.74	1440	1 3 .				
58	14.50	11	3.38	1430	1 5 .				
42	20.00	13	2.98	1430	2 0 .				
34	25.00	15	2.67	1430	2 5 .				
28	30.00	18	2.20	1420	3 0 .				
21	40.00	20	1.58	1420	4 0 .				
17	50.00	24	1.08	1410	5 0 .				
11	76.13	48	3.41	2760	A 0 4 1 0 7 5 . _ N _ - _ - . 0 9 6 A _	18.6	63a	X 6 1 1 0 1 M 0 2 0 - _ - _ -	38
8.0	105.00	61	2.06	2750	1 0 0				
6.4	131.25	69	2.57	2750	1 2 5				
5.5	152.25	84	2.24	2740	1 5 0			X 6 1 1 0 2 M 0 2 0 - _ - _ -	42
4.0	210.00	105	1.27	2730	2 0 0			X 6 1 1 0 1 M 0 2 0 - _ - _ -	38
4.0	210.25	108	1.74	2730	2 2 5			X 6 1 1 0 2 M 0 2 0 - _ - _ -	42
3.2	262.50	118	1.59	2730	2 5 0				
2.9	290.00	123	1.53	2730	3 0 0				
2.3	362.50	150	1.25	2710	3 5 0				
2.1	400.00	149	0.94	2710	4 0 0			X 6 1 1 0 1 M 0 2 0 - _ - _ -	38
1.9	435.00	167	1.13	2710	4 5 0			X 6 1 1 0 2 M 0 2 0 - _ - _ -	42
1.7	500.00	167	1.13	2710	5 0 0				
1.4	600.00	186	1.01	2700	6 0 0				
1.3	625.00	195	0.97	2700	6 2 5				
5.3	157.50	90	3.05	3500	A 0 5 1 0 1 5 0 _ N _ - _ - . 0 9 6 A _	22.6	63a	X 6 1 1 0 2 M 0 2 5 - _ - _ -	42
4.0	210.00	105	2.92	3500	2 0 0			X 6 1 1 0 3 M 0 2 5 - _ - _ -	48
3.9	217.50	116	2.45	3490	2 2 5				
3.2	262.50	124	2.49	3490	2 5 0				
2.9	292.50	134	2.11	3490	3 0 0				
2.3	362.50	158	1.94	3480	3 5 0				
2.2	390.00	155	1.98	3480	4 0 0				
1.9	435.00	182	1.69	3470	4 5 0				
1.7	487.50	181	1.70	3470	5 0 0				
1.4	585.00	207	1.49	3460	6 0 0				
1.3	625.00	211	1.46	3460	6 2 5				
1.1	750.00	240	1.28	3450	7 5 0				
1.0	800.00	230	1.34	3450	8 0 0				
.93	900.00	271	1.14	3430	9 0 0				
.84	1000.00	264	1.17	3440	1 0 C				
.70	1200.00	299	1.03	3420	1 2 C				

NOTE
Other output speeds are available using 2 and 8 pole motors - Please contact our Application Engineers

SELECTION TABLES GEARED MOTORS

0.12 kW

4 POLE

N2 R/MIN	i	M2 Nm	Fm	N	UNIT DESIGNATION	Kg			
Output Speed	Ratio	Output Torque	Service Factor	Overhung Load	Column Entry <input type="text" value="1"/> Through <input type="text" value="20"/> Spaces to be filled when entering order	Weight of Base Mount Unit	Motor Frame Size	Cone Ring Output Coupling Spaces to be filled when entering order	Max Bore Coupling Drive Half
259	5.25	3	5.24	1450	A 0 2 8 0 5 . 0 _ M _ 1 2 4 A _	10.5	63a	X 6 1 2 0 1 M 0 1 6 -	38
185	7.33	5	4.74	1440	7 . 5				
130	10.50	7	4.30	1440	1 0 .				
109	12.50	8	3.88	1440	1 3 .				
94	14.50	9	3.52	1440	1 5 .				
68	20.00	11	3.08	1430	2 0 .				
54	25.00	13	2.76	1430	2 5 .				
45	30.00	15	2.27	1430	3 0 .				
34	40.00	17	1.77	1420	4 0 .				
27	50.00	20	1.21	1420	5 0 .				
23	60.00	21	0.88	1410	6 0 .				
18	76.13	40	3.67	2760	A 0 4 1 0 7 5 . _ N _ 1 2 4 A _	18.5	63a	X 6 1 1 0 1 M 0 2 0 -	38
13	105.00	52	2.35	2760	1 0 0				
10	131.25	58	2.77	2750	1 2 5				
8.9	152.25	71	2.46	2750	1 5 0				
6.5	210.00	88	1.48	2740	2 0 0				
6.5	210.25	91	2.04	2740	2 2 5			X 6 1 1 0 2 M 0 2 0 -	42
5.2	262.50	100	1.88	2740	2 5 0				
4.7	290.00	105	1.80	2740	3 0 0				
3.8	362.50	127	1.49	2720	3 5 0				
3.4	400.00	124	1.09	2720	4 0 0			X 6 1 1 0 1 M 0 2 0 -	38
3.1	435.00	142	1.33	2710	4 5 0			X 6 1 1 0 2 M 0 2 0 -	42
2.7	500.00	142	1.33	2720	5 0 0				
2.3	600.00	158	1.20	2710	6 0 0				
2.2	625.00	165	1.14	2700	6 2 5				
1.8	750.00	183	1.03	2700	7 5 0				
1.7	800.00	176	0.81	2230	8 0 0			X 6 1 1 0 1 M 0 2 0 -	38
8.6	157.50	76	3.39	3500	A 0 5 1 0 1 5 0 _ N _ 1 2 4 A _	22.5	63a	X 6 1 1 0 2 M 0 2 5 -	42
6.5	210.00	90	3.42	3500	2 0 0			X 6 1 1 0 3 M 0 2 5 -	48
6.3	217.50	98	2.75	3500	2 2 5			X 6 1 1 0 2 M 0 2 5 -	42
5.2	262.50	106	2.91	3490	2 5 0			X 6 1 1 0 3 M 0 2 5 -	48
4.6	292.50	115	2.48	3490	3 0 0				
3.8	362.50	135	2.28	3480	3 5 0				
3.7	367.50	110	0.90	3490	3 7 5			X 6 1 1 0 1 M 0 2 5 -	38
3.5	390.00	134	2.31	3490	4 0 0			X 6 1 1 0 3 M 0 2 5 -	48
3.1	435.00	155	1.99	3470	4 5 0				
2.8	487.50	155	1.99	3480	5 0 0				
2.3	585.00	177	1.74	3470	6 0 0				
2.2	625.00	181	1.70	3470	6 2 5				
1.8	750.00	205	1.50	3460	7 5 0				
1.7	800.00	197	1.56	3460	8 0 0				
1.5	900.00	232	1.33	3440	9 0 0				
1.4	1000.00	227	1.36	3450	1 0 C				
1.1	1200.00	255	1.21	3430	1 2 C				
1.1	1250.00	263	1.17	3430	1 2 C				
159	5.25	6	3.82	1436	A 0 2 8 0 5 . 0 _ M _ 1 2 6 A _	10.9	63b	X 6 1 2 0 1 M 0 1 6 -	38
114	7.33	8	3.43	1436	7 . 5				
80	10.50	11	3.10	1434	1 0 .				
67	12.50	13	2.79	1432	1 3 .				
58	14.50	15	2.52	1424	1 5 .				
42	20.00	17	2.23	1422	2 0 .				
33	25.00	21	1.99	1418	2 5 .				
28	30.00	24	1.64	1408	3 0 .				
21	40.00	27	1.18	1406	4 0 .				
17	50.00	32	0.80	1400	5 0 .				
11	76.13	64	2.54	2752	A 0 4 1 0 7 5 . _ N _ 1 2 6 A _	18.9	63b	X 6 1 1 0 1 M 0 2 0 -	38
8.0	105.00	82	1.54	2740	1 0 0				
6.4	131.25	93	1.91	2738	1 2 5				
5.5	152.25	113	1.67	2730	1 5 0			X 6 1 1 0 2 M 0 2 0 -	42
4.0	210.00	141	0.95	2720	2 0 0			X 6 1 1 0 1 M 0 2 0 -	38
4.0	210.25	145	1.30	2720	2 2 5			X 6 1 1 0 2 M 0 2 0 -	42
3.2	262.50	158	1.19	2710	2 5 0				
2.9	290.00	166	1.14	2710	3 0 0				
11	78.75	68	3.52	3504	A 0 5 1 0 7 5 . _ N _ 1 2 6 A _	22.9	63b	X 6 1 1 0 2 M 0 2 5 -	42
8.0	105.00	81	3.52	3502	1 0 0			X 6 1 1 0 3 M 0 2 5 -	48
6.4	131.25	96	3.19	3500	1 2 5				
5.3	157.50	121	2.28	3488	1 5 0			X 6 1 1 0 2 M 0 2 5 -	42
4.0	210.00	142	2.17	3483	2 0 0			X 6 1 1 0 3 M 0 2 5 -	48
3.8	217.50	156	1.83	3473	2 2 5				
3.2	262.50	166	1.86	3473	2 5 0				
2.9	292.50	180	1.57	3470	3 0 0				
2.3	362.50	213	1.45	3450	3 5 0				
2.1	390.00	208	1.48	3460	4 0 0				
1.9	435.00	245	1.26	3440	4 5 0				
1.7	487.50	243	1.27	3440	5 0 0				
1.4	585.00	278	1.11	3430	6 0 0				
1.3	625.00	284	1.09	3430	6 2 5				

NOTE
Other output speeds are available using 2 and 8 pole motors - Please contact our Application Engineers

SERIES AJ

SELECTION TABLES GEARED MOTORS

0.18 kW

4 POLE

6 POLE

N2 R/MIN	i	M2 Nm	Fm	N	UNIT DESIGNATION	Kg			
Output Speed	Ratio	Output Torque	Service Factor	Overhung Load	Column Entry 1 Through 20 Spaces to be filled when entering order	Weight of Base Mount Unit	Motor Frame Size	Cone Ring Output Coupling Spaces to be filled when entering order	Max Bore Coupling Drive Half
259	5.25	5	3.49	1442	A 0 2 8 0 5 . 0 _ M _ _ _ . 1 8 4 A _	10.9	63b	X 6 1 2 0 1 M 0 1 6 - _ _ _	38
185	7.33	7	3.16	1435	7 . 5				
130	10.50	10	2.87	1432	1 0 .				
109	12.50	12	2.58	1430	1 3 .				
94	14.50	14	2.34	1430	1 5 .				
68	20.00	16	2.05	1420	2 0 .				
54	25.00	20	1.84	1415	2 5 .				
45	30.00	23	1.52	1413	3 0 .				
34	40.00	26	1.18	1401	4 0 .				
27	50.00	30	0.81	1390	5 0 .				
18	76.13	60	2.44	2750	A 0 4 1 0 7 5 . _ N _ _ _ . 1 8 4 A _	18.9	63b	X 6 1 1 0 1 M 0 2 0 - _ _ _	38
13	105.00	78	1.57	2745	1 0 0				
10	131.25	88	1.85	2735	1 2 5				
8.9	152.25	107	1.64	2731	1 5 0				
6.5	210.00	132	0.98	2710	2 0 0				
6.5	210.25	137	1.36	2232	2 2 5			X 6 1 1 0 2 M 0 2 0 - _ _ _	42
5.2	262.50	151	1.25	2710	2 5 0				
4.7	290.00	157	1.20	2710	3 0 0				
17	78.75	64	3.22	3502	A 0 5 1 0 7 5 . _ N _ _ _ . 1 8 4 A _	22.9	63b	X 6 1 1 0 2 M 0 2 5 - _ _ _	42
13	105.00	77	3.22	3500	1 0 0				
10	131.25	92	3.06	3495	1 2 5			X 6 1 1 0 3 M 0 2 5 - _ _ _	48
8.6	157.50	114	2.26	3485	1 5 0			X 6 1 1 0 2 M 0 2 5 - _ _ _	42
6.5	210.00	135	2.28	3481	2 0 0			X 6 1 1 0 3 M 0 2 5 - _ _ _	48
6.3	217.50	148	1.83	3476	2 2 5			X 6 1 1 0 2 M 0 2 5 - _ _ _	42
5.2	262.50	159	1.94	3466	2 5 0			X 6 1 1 0 3 M 0 2 5 - _ _ _	48
4.6	292.50	173	1.65	3466	3 0 0				
3.8	362.50	203	1.52	3450	3 5 0				
3.5	390.00	201	1.54	3450	4 0 0				
3.1	435.00	233	1.32	3440	4 5 0				
2.8	487.50	232	1.33	3440	5 0 0				
2.3	585.00	265	1.16	3430	6 0 0				
2.2	625.00	272	1.14	3420	6 2 5				
160	5.25	9	2.56	1428	A 0 2 8 0 5 . 0 _ M _ _ _ . 1 8 6 A _	12.8	71a	X 6 1 2 0 1 M 0 1 6 - _ _ _	38
115	7.33	12	2.30	1428	7 . 5				
80	10.50	17	2.08	1423	1 0 .				
67	12.50	19	1.87	1417	1 3 .				
58	14.50	22	1.69	1413	1 5 .				
42	20.00	26	1.49	1407	2 0 .				
34	25.00	31	1.34	1396	2 5 .				
28	30.00	36	1.10	1386	3 0 .				
43	19.50	30	3.36	2760	A 0 4 1 0 2 0 . _ M _ _ _ . 1 8 6 A _	15.8	71a	X 6 1 1 0 1 M 0 2 0 - _ _ _	38
34	25.00	34	3.33	2760	2 5 .				
28	30.00	39	2.94	2760	3 0 .				
21	40.00	49	2.17	2760	4 0 .				
17	50.00	57	1.41	2750	5 0 .			X 6 1 2 0 1 M 0 2 0 - _ _ _	38
14	60.00	60	1.04	2750	6 0 .				
11	76.13	96	1.71	2737	A 0 4 1 0 7 5 . _ N _ _ _ . 1 8 6 A _	20.8	71a	X 6 1 1 0 1 M 0 2 0 - _ _ _	38
8.0	105.00	123	1.03	2721	1 0 0				
6.4	131.25	139	1.28	2716	1 2 5				
5.5	152.25	169	1.12	2710	1 5 0			X 6 1 1 0 2 M 0 2 0 - _ _ _	42
11	78.75	102	2.36	3493	A 0 5 1 0 7 5 . _ N _ _ _ . 1 8 6 A _	24.8	71a	X 6 1 1 0 2 M 0 2 5 - _ _ _	42
8.0	105.00	121	2.36	3487	1 0 0			X 6 1 1 0 3 M 0 2 5 - _ _ _	48
6.4	131.25	144	2.14	3481	1 2 5				
5.3	157.50	180	1.53	3466	1 5 0			X 6 1 1 0 2 M 0 2 5 - _ _ _	42
4.0	210.00	211	1.46	3450	2 0 0			X 6 1 1 0 3 M 0 2 5 - _ _ _	48
3.9	217.50	232	1.23	3440	2 2 5				
3.2	262.50	248	1.24	3440	2 5 0				
2.9	292.50	269	1.05	3430	3 0 0				
8.2	102.38	126	3.85	6130	A 0 6 1 0 1 0 0 _ N _ _ _ . 1 8 6 A _	33.8	71a	X 6 1 1 0 4 M 0 2 8 - _ _ _	60
6.4	131.25	149	3.36	6130	1 2 5				
5.5	152.25	190	2.58	6060	1 5 0				
4.1	204.75	223	2.25	5920	2 0 0				
4.0	210.25	243	2.06	5840	2 2 5				
3.2	262.50	261	1.92	5750	2 5 0				
3.0	282.75	313	1.60	5500	3 0 0				
2.3	362.50	328	1.53	5450	3 5 0				
2.2	380.25	361	1.39	5270	4 0 0				
1.9	435.00	369	1.36	5250	4 5 0				
1.7	487.50	420	1.19	4990	5 0 0				
1.3	625.00	460	1.09	4810	6 2 5				
7.0	120.00	164	3.67	6970	A 0 7 3 0 1 2 5 _ N _ _ _ . 1 8 6 A _	46.8	71a	X 6 1 1 0 4 M 0 3 0 - _ _ _	60
5.5	152.25	200	3.01	6960	1 5 0				
4.1	204.75	255	2.36	6940	2 0 0				
4.0	210.25	255	2.36	6940	2 2 5				
3.2	262.50	288	2.09	6920	2 5 0				
2.9	290.00	329	1.83	6910	3 0 0				
2.5	336.00	363	1.66	6900	3 5 0				
2.3	362.50	306	0.95	6910	3 7 5			X 6 1 1 0 3 M 0 3 0 - _ _ _	48
2.2	390.00	417	1.44	6870	4 0 0			X 6 1 1 0 4 M 0 3 0 - _ _ _	60
1.9	435.00	417	1.44	6870	4 5 0				
1.7	500.00	466	1.29	6850	5 0 0				
1.4	600.00	534	1.13	6820	6 0 0				
1.3	625.00	510	1.18	6830	6 2 5				

NOTE
Other output speeds are available using 2 and 8 pole motors - Please contact our Application Engineers

SERIES AJ

SELECTION TABLES

GEARED MOTORS

0.25 kW

4 POLE

N2 R/MIN	i	M2 Nm	Fm	N	UNIT DESIGNATION	Kg			
Output Speed	Ratio	Output Torque	Service Factor	Overhung Load	Column Entry 1 Through 20 Spaces to be filled when entering order	Weight of Base Mount Unit	Motor Frame Size	Cone Ring Output Coupling Spaces to be filled when entering order	Max Bore Coupling Drive Half
261	5.25	7	2.53	1434	A 0 2 8 0 5 . 0 _ M _ _ _ . 2 5 4 A _	12.3	71a	X 6 1 2 0 1 M 0 1 6 - _ _ _	38
187	7.33	10	2.29	1429	7 . 5				
130	10.50	14	2.08	1424	1 0 .				
110	12.50	16	1.87	1419	1 3 .				
94	14.50	19	1.70	1419	1 5 .				
69	20.00	23	1.49	1409	2 0 .				
55	25.00	27	1.33	1398	2 5 .				
46	30.00	31	1.10	1393	3 0 .				
34	40.00	36	0.85	1380	4 0 .				
70	19.50	26	3.37	2760	A 0 4 1 0 2 0 . _ M _ _ _ . 2 5 4 A _	15.3	71a	X 6 1 2 0 1 M 0 2 0 - _ _ _ X 6 1 1 0 1 M 0 2 0 - _ _ _	38 38
55	25.00	30	3.32	2760	2 5 .				
46	30.00	34	2.93	2760	3 0 .				
34	40.00	42	2.18	2760	4 0 .				
27	50.00	50	1.54	2750	5 0 .			X 6 1 2 0 1 M 0 2 0 - _ _ _	38
23	60.00	53	1.13	2750	6 0 .				
20	70.00	58	0.84	2750	7 0 .				
18	76.13	84	1.77	2739	A 0 4 1 0 7 5 . _ N _ _ _ . 2 5 4 A _	20.3	71a	X 6 1 1 0 1 M 0 2 0 - _ _ _	38
13	105.00	108	1.14	2728	1 0 0				
10	131.25	121	1.34	2718	1 2 5				
9.0	152.25	147	1.19	2710	1 5 0				
6.5	210.25	189	0.99	1640	2 2 5			X 6 1 1 0 2 M 0 2 0 - _ _ _	42
17	78.75	89	2.34	3494	A 0 5 1 0 7 5 . _ N _ _ _ . 2 5 4 A _	24.3	71a X 6	1 1 0 2 M 0 2 5 - _ _ _ 42	
13	105.00	107	2.34	3489	1 0 0				
10	131.25	126	2.22	3478	1 2 5			X 6 1 1 0 3 M 0 2 5 - _ _ _	48
8.7	157.50	157	1.64	3468	1 5 0			X 6 1 1 0 2 M 0 2 5 - _ _ _	42
6.5	210.00	187	1.65	3460	2 0 0			X 6 1 1 0 3 M 0 2 5 - _ _ _	48
6.3	217.50	204	1.33	3450	2 2 5			X 6 1 1 0 2 M 0 2 5 - _ _ _	42
5.2	262.50	219	1.41	3440	2 5 0			X 6 1 1 0 3 M 0 2 5 - _ _ _	48
4.7	292.50	238	1.20	3440	3 0 0				
10	131.25	131	3.53	6130	A 0 6 1 0 1 2 5 _ N _ _ _ . 2 5 4 A _	33.3	71a	X 6 1 1 0 3 M 0 2 8 - _ _ _	48
9.0	152.25	165	2.73	6130	1 5 0				
6.7	204.75	196	2.55	6000	2 0 0			X 6 1 1 0 4 M 0 2 8 - _ _ _	60
6.5	210.25	211	2.28	5920	2 2 5				
5.2	262.50	229	2.18	5840	2 5 0				
4.8	282.75	274	1.83	5600	3 0 0				
3.8	362.50	288	1.73	5550	3 5 0				
3.6	380.25	317	1.58	5380	4 0 0				
3.1	435.00	324	1.55	5370	4 5 0				
2.8	487.50	369	1.36	5120	5 0 0				
2.3	585.00	412	1.21	4880	6 0 0				
2.2	625.00	404	1.24	4950	6 2 5				
1.9	723.33	413	0.85	4730	7 0 0			X 6 1 1 0 3 M 0 2 8 - _ _ _	48
9.0	152.25	175	3.44	6970	A 0 7 3 0 1 5 0 _ N _ _ _ . 2 5 4 A _	46.3	71a	X 6 1 1 0 4 M 0 3 0 - _ _ _	60
6.7	204.75	223	2.70	6950	2 0 0				
6.5	210.25	224	2.69	6950	2 2 5				
5.2	262.50	254	2.37	6940	2 5 0				
4.7	290.00	289	2.09	6920	3 0 0				
4.1	336.00	320	1.88	6900	3 5 0				
3.8	362.50	267	1.06	6920	3 7 5			X 6 1 1 0 3 M 0 3 0 - _ _ _	48
3.5	390.00	365	1.65	6890	4 0 0			X 6 1 1 0 4 M 0 3 0 - _ _ _	60
3.1	435.00	367	1.64	6890	4 5 0				
2.7	500.00	410	1.47	6860	5 0 0				
2.3	600.00	469	1.28	6830	6 0 0				
2.2	625.00	449	1.34	6840	6 2 5				
2.0	676.67	459	0.84	6820	7 0 0			X 6 1 1 0 3 M 0 3 0 - _ _ _	48
1.8	750.00	511	1.18	6810	7 5 0			X 6 1 1 0 4 M 0 3 0 - _ _ _	60

NOTE
Other output speeds are available using 2 and 8 pole motors - Please contact our Application Engineers

SERIES AJ

SELECTION TABLES GEARED MOTORS

0.25 kW

6 POLE

N2 R/MIN	i	M2 Nm	Fm	N	UNIT DESIGNATION	Kg			
Output Speed	Ratio	Output Torque	Service Factor	Overhung Load	Column Entry 1 Through 20 Spaces to be filled when entering order	Weight of Base Mount Unit	Motor Frame Size	Cone Ring Output Coupling Spaces to be filled when entering order	Max Bore Coupling Drive Half
161	5.25	12	1.86	1420	A 0 2 8 0 5 . 0 _ M _ - _ _ . 2 5 6 A _	13.3	71b	X 6 1 2 0 1 M 0 1 6 - _ _ _	38
115	7.33	17	1.67	1420	7 . 5				
80	10.50	23	1.50	1410	1 0 .				
68	12.50	26	1.36	1400	1 3 .				
58	14.50	30	1.23	1400	1 5 .				
42	20.00	36	1.08	1390	2 0 .				
34	25.00	43	0.97	1370	2 5 .				
115	7.33	17	3.70	2768	A 0 4 1 0 7 . 5 _ M _ - _ _ . 2 5 6 A _	16.3	71b	X 6 1 2 0 1 M 0 2 0 - _ _ _	38
80	10.50	24	3.63	2766	1 0 .				
68	12.50	28	3.34	2766	1 3 .			X 6 1 1 0 1 M 0 2 0 - _ _ _	38
58	14.50	31	3.21	2766	1 5 .				
43	19.50	41	2.43	2756	2 0 .				
34	25.00	48	2.42	2754	2 5 .				
28	30.00	55	2.13	2754	3 0 .				
21	40.00	67	1.57	2750	4 0 .				
17	50.00	79	1.02	2742	5 0 .			X 6 1 2 0 1 M 0 2 0 - _ _ _	38
11	76.13	133	1.24	2720	A 0 4 1 0 7 5 . _ N _ - _ _ . 2 5 6 A _	21.3	71b	X 6 1 1 0 1 M 0 2 0 - _ _ _	38
6.4	131.25	192	0.93	2690	1 2 5			X 6 1 1 0 2 M 0 2 0 - _ _ _	42
11	78.75	141	1.71	3480	A 0 5 1 0 7 5 . _ N _ - _ _ . 2 5 6 A _	25.3	71b	X 6 1 1 0 2 M 0 2 5 - _ _ _	42
8.0	105.00	168	1.71	3470	1 0 0			X 6 1 1 0 3 M 0 2 5 - _ _ _	48
6.4	131.25	199	1.55	3460	1 2 5				
5.4	157.50	249	1.11	3440	1 5 0			X 6 1 1 0 2 M 0 2 5 - _ _ _	42
11	76.13	146	2.91	5988	A 0 6 1 0 7 5 . _ N _ - _ _ . 2 5 6 A _	34.3	71b	X 6 1 1 0 3 M 0 2 8 - _ _ _	48
8.3	102.38	174	2.78	5933	1 0 0			X 6 1 1 0 4 M 0 2 8 - _ _ _	60
6.4	131.25	205	2.43	5870	1 2 5				
5.6	152.25	263	1.87	5698	1 5 0				
4.1	204.75	307	1.63	5492	2 0 0				
4.0	210.25	335	1.49	5370	2 2 5				
3.2	262.50	361	1.39	5250	2 5 0				
3.0	282.75	432	1.16	4890	3 0 0				
2.3	362.50	453	1.11	4790	3 5 0				
12	69.60	154	3.66	6981	A 0 7 3 0 7 5 . _ N _ - _ _ . 2 5 6 A _	47.3	71b	X 6 1 1 0 4 M 0 3 0 - _ _ _	60
9.0	93.60	197	3.05	6955	1 0 0				
7.0	120.00	227	2.65	6941	1 2 5				
5.6	152.25	276	2.18	6926	1 5 0				
4.1	204.75	352	1.71	6895	2 0 0				
4.0	210.25	353	1.71	6895	2 2 5				
3.2	262.50	398	1.51	6870	2 5 0				
2.9	290.00	455	1.32	6850	3 0 0				
2.5	336.00	502	1.20	6820	3 5 0				

NOTE
Other output speeds are available using 2 and 8 pole motors - Please contact our Application Engineers

SELECTION TABLES GEARED MOTORS

0.37 kW

4 POLE

6 POLE

N2 R/MIN	i	M2 Nm	Fm	N	UNIT DESIGNATION	Kg			
Output Speed	Ratio	Output Torque	Service Factor	Overhung Load	Column Entry <input type="checkbox"/> 1 Through <input type="checkbox"/> 20 Spaces to be filled when entering order	Weight of Base Mount Unit	Motor Frame Size	Cone Ring Output Coupling Spaces to be filled when entering order	Max Bore Coupling Drive Half
263	5.25	11	1.72	1420	A 0 2 8 0 5 . 0 _ M _ 3 7 4 A _	13.0	71b	X 6 1 2 0 1 M 0 1 6 -	38
188	7.33	15	1.56	1420	7 . 5				
131	10.50	21	1.41	1410	1 0 .				
110	12.50	24	1.28	1400	1 3 .				
95	14.50	28	1.16	1400	1 5 .				
69	20.00	34	1.01	1390	2 0 .				
55	25.00	40	0.91	1370	2 5 .				
263	5.25	11	3.91	2767	A 0 4 1 0 5 . 0 _ M _ 3 7 4 A _	16.0	71b	X 6 1 2 0 1 M 0 2 0 -	38
188	7.33	16	3.45	2767	7 . 5				
131	10.50	22	3.40	2767	1 0 .				
110	12.50	25	3.14	2765	1 3 .				
95	14.50	29	3.01	2765	1 5 .				
71	19.50	38	2.30	2755	2 0 .				
55	25.00	44	2.26	2755	2 5 .			X 6 1 1 0 1 M 0 2 0 -	38
46	30.00	51	1.99	2752	3 0 .				
35	40.00	63	1.48	2748	4 0 .				
28	50.00	73	1.05	2742	5 0 .			X 6 1 2 0 1 M 0 2 0 -	38
18	76.13	123	1.21	2720	A 0 4 1 0 7 5 . _ N _ 3 7 4 A _	21.0	71b	X 6 1 1 0 1 M 0 2 0 -	38
11	131.25	178	0.91	2690	1 2 5				
18	78.75	130	1.59	3480	A 0 5 1 0 7 5 . _ N _ 3 7 4 A _	25.0	71b	X 6 1 1 0 2 M 0 2 5 -	42
13	105.00	157	1.59	3470	1 0 0				
11	131.25	186	1.51	3450	1 2 5			X 6 1 1 0 3 M 0 2 5 -	48
8.8	157.50	232	1.12	3440	1 5 0			X 6 1 1 0 2 M 0 2 5 -	42
18	76.13	135	2.83	5976	A 0 6 1 0 7 5 . _ N _ 3 7 4 A _	34.0	71b	X 6 1 1 0 3 M 0 2 8 -	48
13	102.38	162	2.75	5911	1 0 0				
11	131.25	192	2.41	5837	1 2 5				
9.1	152.25	243	1.86	5702	1 5 0				
6.7	204.75	288	1.74	5490	2 0 0			X 6 1 1 0 4 M 0 2 8 -	60
6.6	210.25	311	1.55	5370	2 2 5				
5.3	262.50	337	1.48	5240	2 5 0				
4.9	282.75	403	1.24	4880	3 0 0				
3.8	362.50	424	1.18	4780	3 5 0				
20	69.60	142	3.40	6978	A 0 7 3 0 7 5 . _ N _ 3 7 4 A _	47.0	71b	X 6 1 1 0 4 M 0 3 0 -	60
15	93.60	183	3.16	6953	1 0 0				
11	120.00	213	2.83	6946	1 2 5				
9.1	152.25	257	2.34	6926	1 5 0				
6.7	204.75	328	1.84	6894	2 0 0				
6.6	210.25	329	1.83	6894	2 2 5				
5.3	262.50	373	1.61	6870	2 5 0				
4.8	290.00	424	1.42	6850	3 0 0				
4.1	336.00	470	1.28	6820	3 5 0				
176	5.25	17	3.12	2764	A 0 4 1 0 5 . 0 _ M _ 3 7 6 A _	19.8	80a	X 6 1 2 0 1 M 0 2 0 -	38
126	7.33	23	2.73	2764	7 . 5				
88	10.50	32	2.68	2759	1 0 .				
74	12.50	38	2.47	2759	1 3 .			X 6 1 1 0 1 M 0 2 0 -	38
64	14.50	42	2.37	2759	1 5 .				
47	19.50	56	1.80	2749	2 0 .				
37	25.00	64	1.79	2744	2 5 .				
31	30.00	74	1.57	2744	3 0 .				
23	40.00	91	1.16	2734	4 0 .				
64	14.50	45	3.33	3510	A 0 5 1 0 1 5 . _ M _ 3 7 6 A _	23.8	80a	X 6 1 1 0 1 M 0 2 5 -	38
46	20.00	55	3.54	3510	2 0 .			X 6 1 1 0 2 M 0 2 5 -	42
37	25.00	66	2.97	3500	2 5 .				
31	30.00	77	2.45	3500	3 0 .				
23	40.00	97	1.82	3490	4 0 .			X 6 1 1 0 1 M 0 2 5 -	38
19	50.00	112	1.32	3480	5 0 .				
15	60.00	126	0.91	3480	6 0 .				
31	30.00	79	3.78	6130	A 0 6 1 0 3 0 . _ M _ 3 7 6 A _	29.8	80a	X 6 1 1 0 3 M 0 2 8 -	48
23	40.00	99	2.79	6130	4 0 .			X 6 1 1 0 2 M 0 2 8 -	42
19	50.00	115	2.13	6130	5 0 .				
15	60.00	130	1.45	6130	6 0 .				
13	70.00	140	1.09	6110	7 0 .			X 6 1 1 0 1 M 0 2 8 -	38
12	76.13	197	2.15	5744	A 0 6 1 0 7 5 . _ N _ 3 7 6 A _	37.8	80a	X 6 1 1 0 3 M 0 2 8 -	48
9.0	102.38	235	2.06	5595	1 0 0			X 6 1 1 0 4 M 0 2 8 -	60
7.0	131.25	278	1.80	5426	1 2 5				
6.1	152.25	355	1.38	5080	1 5 0				
4.5	204.75	416	1.20	4760	2 0 0				
23	40.00	111	3.96	6980	A 0 7 3 0 4 0 . _ M _ 3 7 6 A _	42.8	80a	X 6 1 1 0 3 M 0 3 0 -	48
19	50.00	133	3.10	6980	5 0 .				
15	60.00	149	2.20	6970	6 0 .				
13	70.00	162	1.59	6960	7 0 .			X 6 1 1 0 2 M 0 3 0 -	42
13	69.60	208	2.71	6948	A 0 7 3 0 7 5 . _ N _ 3 7 6 A _	50.8	80a	X 6 1 1 0 4 M 0 3 0 -	60
10	93.60	267	2.26	6913	1 0 0				
7.7	120.00	307	1.96	6892	1 2 5				
6.1	152.25	373	1.61	6870	1 5 0				
4.5	204.75	476	1.27	6820	2 0 0				
4.4	210.25	477	1.26	6820	2 2 5				

NOTE
Other output speeds are available using 2 and 8 pole motors - Please contact our Application Engineers

SERIES AJ

SELECTION TABLES

GEARED MOTORS

0.55 kW

4 POLE

N2 R/MIN	i	M2 Nm	Fm	N	UNIT DESIGNATION	Kg			
Output Speed	Ratio	Output Torque	Service Factor	Overhung Load	Column Entry 1 Through 20 Spaces to be filled when entering order	Weight of Base Mount Unit	Motor Frame Size	Cone Ring Output Coupling Spaces to be filled when entering order	Max Bore Coupling Drive Half
261	5.25	17	2.61	2764	A 0 4 1 0 5 . 0 _ M _ _ _ . 5 5 4 A _	19.4	80a	X 6 1 2 0 1 M 0 2 0 - _ _ _	38
187	7.33	24	2.30	2764	7 . 5				
130	10.50	33	2.27	2764	1 0 .				
110	12.50	38	2.10	2758	1 3 .				
94	14.50	44	2.01	2758	1 5 .				
70	19.50	57	1.53	2748	2 0 .				
55	25.00	66	1.51	2748	2 5 .			X 6 1 1 0 1 M 0 2 0 - _ _ _	38
46	30.00	76	1.33	2742	3 0 .				
34	40.00	94	0.99	2730	4 0 .				
187	7.33	24	3.95	3520	A 0 5 1 0 7 . 5 _ M _ _ _ . 5 5 4 A _	23.4	80a	X 6 1 1 0 1 M 0 2 5 - _ _ _	38
130	10.50	34	3.97	3510	1 0 .				
110	12.50	39	3.50	3510	1 3 .				
94	14.50	45	3.13	3510	1 5 .				
69	20.00	57	2.99	3510	2 0 .				
55	25.00	69	2.49	3500	2 5 .				
46	30.00	80	2.06	3500	3 0 .				
34	40.00	101	1.56	3490	4 0 .				
27	50.00	116	1.21	3480	5 0 .				
23	60.00	131	0.84	3480	6 0 .				
55	25.00	71	3.92	6130	A 0 6 1 0 2 5 . _ M _ _ _ . 5 5 4 A _	29.4	80a	X 6 1 1 0 3 M 0 2 8 - _ _ _	48
46	30.00	81	3.18	6130	3 0 .			X 6 1 1 0 2 M 0 2 8 - _ _ _	42
34	40.00	102	2.35	6130	4 0 .				
27	50.00	120	1.84	6130	5 0 .				
23	60.00	136	1.33	6130	6 0 .			X 6 1 1 0 1 M 0 2 8 - _ _ _	38
20	70.00	146	1.00	6090	7 0 .				
18	76.13	203	1.89	5746	A 0 6 1 0 7 5 . _ N _ _ _ . 5 5 4 A _	37.4	80a	X 6 1 1 0 3 M 0 2 8 - _ _ _	48
13	102.38	243	1.84	5584	1 0 0				
10	131.25	288	1.61	5398	1 2 5				
9.0	152.25	364	1.24	5060	1 5 0				
34	40.00	114	3.37	6980	A 0 7 3 0 4 0 . _ M _ _ _ . 5 5 4 A _	42.4	80a	X 6 1 1 0 3 M 0 3 0 - _ _ _	48
27	50.00	136	2.65	6980	5 0 .				
23	60.00	154	2.03	6970	6 0 .				
20	70.00	167	1.47	6960	7 0 .			X 6 1 1 0 2 M 0 3 0 - _ _ _	42
20	69.60	213	2.27	6946	A 0 7 3 0 7 5 . _ N _ _ _ . 5 5 4 A _	50.4	80a	X 6 1 1 0 4 M 0 3 0 - _ _ _	60
15	93.60	275	2.11	6914	1 0 0				
11	120.00	319	1.89	6896	1 2 5				
9.0	152.25	385	1.56	6860	1 5 0				
6.7	204.75	491	1.23	6810	2 0 0				
6.5	210.25	493	1.22	6810	2 2 5				
176	5.25	26	2.10	2760	A 0 4 1 0 5 . 0 _ M _ _ _ . 5 5 6 A _	21.3	80b	X 6 1 2 0 1 M 0 2 0 - _ _ _	38
126	7.33	35	1.84	2760	7 . 5				
88	10.50	49	1.80	2750	1 0 .				
74	12.50	56	1.66	2750	1 3 .			X 6 1 1 0 1 M 0 2 0 - _ _ _	38
64	14.50	63	1.60	2750	1 5 .				
47	19.50	84	1.21	2740	2 0 .				
37	25.00	96	1.20	2730	2 5 .				
31	30.00	110	1.06	2730	3 0 .				
126	7.33	36	3.17	3515	A 0 5 1 0 7 . 5 _ M _ _ _ . 5 5 6 A _	25.3	80b	X 6 1 1 0 1 M 0 2 5 - _ _ _	38
88	10.50	49	3.17	3505	1 0 .				
74	12.50	58	2.79	3502	1 3 .				
64	14.50	66	2.24	3500	1 5 .				
46	20.00	83	2.38	3497	2 0 .			X 6 1 1 0 2 M 0 2 5 - _ _ _	42
37	25.00	99	2.00	3487	2 5 .				
31	30.00	115	1.65	3482	3 0 .				
23	40.00	145	1.22	3471	4 0 .			X 6 1 1 0 1 M 0 2 5 - _ _ _	38
19	50.00	166	0.89	3460	5 0 .				
62	15.00	69	3.75	6047	A 0 6 1 0 1 5 . _ M _ _ _ . 5 5 6 A _	31.3	80b	X 6 1 1 0 2 M 0 2 8 - _ _ _	42
46	20.00	85	3.50	6014	2 0 .			X 6 1 1 0 3 M 0 2 8 - _ _ _	48
37	25.00	102	3.15	5980	2 5 .				
31	30.00	118	2.54	5967	3 0 .				
23	40.00	147	1.87	5920	4 0 .			X 6 1 1 0 2 M 0 2 8 - _ _ _	42
19	50.00	172	1.43	5883	5 0 .				
15	60.00	194	0.97	5793	6 0 .				
12	76.13	293	1.45	5380	A 0 6 1 0 7 5 . _ N _ _ _ . 5 5 6 A _	39.3	80b	X 6 1 1 0 3 M 0 2 8 - _ _ _	48
9.0	102.38	349	1.39	5090	1 0 0			X 6 1 1 0 4 M 0 2 8 - _ _ _	60
7.0	131.25	413	1.21	4760	1 2 5				
31	30.00	130	3.68	6979	A 0 7 3 0 3 0 . _ M _ _ _ . 5 5 6 A _	44.3	80b	X 6 1 1 0 4 M 0 3 0 - _ _ _	60
23	40.00	165	2.66	6954	4 0 .			X 6 1 1 0 3 M 0 3 0 - _ _ _	48
19	50.00	198	2.08	6947	5 0 .				
15	60.00	222	1.48	6936	6 0 .				
13	70.00	241	1.07	6922	7 0 .			X 6 1 1 0 2 M 0 3 0 - _ _ _	42
13	69.60	309	1.82	6900	A 0 7 3 0 7 5 . _ N _ _ _ . 5 5 6 A _	52.3	80b	X 6 1 1 0 4 M 0 3 0 - _ _ _	60
10	93.60	396	1.52	6850	1 0 0				
7.7	120.00	456	1.32	6820	1 2 5				

NOTE
Other output speeds are available using 2 and 8 pole motors - Please contact our Application Engineers

SERIES AJ

SELECTION TABLES

GEARED MOTORS

0.75 kW

4 POLE

6 POLE

N2 R/MIN	i	M2 Nm	Fm	N	UNIT DESIGNATION	Kg			
Output Speed	Ratio	Output Torque	Service Factor	Overhung Load	Column Entry 1 Through 20 Spaces to be filled when entering order	Weight of Base Mount Unit	Motor Frame Size	Cone Ring Output Coupling Spaces to be filled when entering order	Max Bore Coupling Drive Half
264	5.25	23	1.94	2760	A 0 4 1 0 5 . 0 _ M _ _ _ . 7 5 4 A _	20.5	80b	X 6 1 2 0 1 M 0 2 0 - _ _ _	38
189	7.33	32	1.71	2760	7 . 5				
132	10.50	45	1.68	2760	1 0 .				
111	12.50	52	1.55	2750	1 3 .				
96	14.50	59	1.49	2750	1 5 .				
71	19.50	77	1.14	2740	2 0 .				
55	25.00	89	1.12	2740	2 5 .			X 6 1 1 0 1 M 0 2 0 - _ _ _	38
46	30.00	103	0.99	2730	3 0 .				
189	7.33	33	2.93	3515	A 0 5 1 0 7 . 5 _ M _ _ _ . 7 5 4 A _	24.5	80b	X 6 1 1 0 1 M 0 2 5 - _ _ _	38
132	10.50	46	2.94	3505	1 0 .				
111	12.50	53	2.60	3505	1 3 .				
96	14.50	61	2.32	3503	1 5 .				
69	20.00	77	2.22	3501	2 0 .				
55	25.00	93	1.85	3489	2 5 .				
46	30.00	107	1.53	3487	3 0 .				
35	40.00	136	1.16	3475	4 0 .				
28	50.00	157	0.90	3460	5 0 .				
143	9.67	43	4.00	6106	A 0 6 1 0 1 0 . _ M _ _ _ . 7 5 4 A _	30.5	80b	X 6 1 1 0 1 M 0 2 8 - _ _ _	38
92	15.00	64	3.50	6072	1 5 .			X 6 1 1 0 2 M 0 2 8 - _ _ _	42
69	20.00	79	3.52	6045	2 0 .			X 6 1 1 0 3 M 0 2 8 - _ _ _	48
55	25.00	96	2.90	6033	2 5 .				
46	30.00	110	2.36	6006	3 0 .			X 6 1 1 0 2 M 0 2 8 - _ _ _	42
35	40.00	138	1.74	5972	4 0 .				
28	50.00	162	1.36	5937	5 0 .				
23	60.00	183	0.99	5880	6 0 .				
18	76.13	274	1.40	5490	A 0 6 1 0 7 5 . _ N _ _ _ . 7 5 4 A _	38.5	80b	X 6 1 1 0 3 M 0 2 8 - _ _ _	48
14	102.38	328	1.36	5220	1 0 0				
11	131.25	388	1.19	4910	1 2 5				
46	30.00	121	3.41	6984	A 0 7 3 0 3 0 . _ M _ _ _ . 7 5 4 A _	43.5	80b	X 6 1 1 0 3 M 0 3 0 - _ _ _	48
35	40.00	153	2.50	6960	4 0 .				
28	50.00	184	1.96	6954	5 0 .				
23	60.00	208	1.50	6942	6 0 .				
20	70.00	226	1.09	6930	7 0 .			X 6 1 1 0 2 M 0 3 0 - _ _ _	42
20	69.60	287	1.68	6910	A 0 7 3 0 7 5 . _ N _ _ _ . 7 5 4 A _	51.5	80b	X 6 1 1 0 4 M 0 3 0 - _ _ _	60
15	93.60	371	1.57	6870	1 0 0				
12	120.00	430	1.40	6840	1 2 5				
190	4.80	33	3.29	3514	A 0 5 1 0 5 . 0 _ M _ _ _ . 7 5 6 A _	28.4	90S	X 6 1 1 0 1 M 0 2 5 - _ _ _	38
124	7.33	50	2.29	3509	7 . 5				
87	10.50	69	2.29	3499	1 0 .				
73	12.50	80	2.01	3494	1 3 .				
63	14.50	92	1.62	3489	1 5 .				
46	20.00	115	1.72	3483	2 0 .			X 6 1 1 0 2 M 0 2 5 - _ _ _	42
36	25.00	137	1.44	3473	2 5 .				
30	30.00	159	1.19	3463	3 0 .				
23	40.00	201	0.88	3450	4 0 .				
124	7.33	51	3.53	6094	A 0 6 1 0 7 . 5 _ M _ _ _ . 7 5 6 A _	34.4	90S	X 6 1 1 0 1 M 0 2 8 - _ _ _	38
94	9.67	65	3.11	6049	1 0 .			X 6 1 1 0 2 M 0 2 8 - _ _ _	42
73	12.50	82	3.16	5999	1 3 .				
61	15.00	96	2.70	5955	1 5 .				
46	20.00	118	2.53	5887	2 0 .			X 6 1 1 0 3 M 0 2 8 - _ _ _	48
36	25.00	141	2.27	5814	2 5 .				
30	30.00	163	1.83	5786	3 0 .				
23	40.00	204	1.35	5687	4 0 .			X 6 1 1 0 2 M 0 2 8 - _ _ _	42
18	50.00	238	1.03	5610	5 0 .				
47	19.50	129	3.10	6970	A 0 7 3 0 2 0 . _ M _ _ _ . 7 5 6 A _	47.4	90S	X 6 1 1 0 3 M 0 3 0 - _ _ _	48
36	25.00	154	3.13	6962	2 5 .			X 6 1 1 0 4 M 0 3 0 - _ _ _	60
30	30.00	180	2.65	6956	3 0 .				
23	40.00	229	1.92	6926	4 0 .			X 6 1 1 0 3 M 0 3 0 - _ _ _	48
18	50.00	275	1.50	6912	5 0 .				
15	60.00	307	1.07	6900	6 0 .				
23	40.00	233	2.93	8860	A 0 8 6 0 4 0 . _ M _ _ _ . 7 5 6 A _	64.4	90S	X 6 1 1 0 4 M 0 3 5 - _ _ _	60
18	50.00	277	2.21	8860	5 0 .				
15	60.00	314	1.63	8850	6 0 .				
13	70.00	344	1.21	8840	7 0 .			X 6 1 1 0 3 M 0 3 5 - _ _ _	48

NOTE
Other output speeds are available using 2 and 8 pole motors - Please contact our Application Engineers

SERIES AJ

SELECTION TABLES

GEARED MOTORS

1.1 kW

4 POLE

6 POLE

N2 R/MIN	i	M2 Nm	Fm	N	UNIT DESIGNATION	Kg			
Output Speed	Ratio	Output Torque	Service Factor	Overhung Load	Column Entry 1 Through 20 Spaces to be filled when entering order	Weight of Base Mount Unit	Motor Frame Size	Cone Ring Output Coupling Spaces to be filled when entering order	Max Bore Coupling Drive Half
288	4.80	33	2.82	3514	A 0 5 1 0 5 . 0 _ M _ - _ _ 1 . 1 4 A _	27.8	90S	X 6 1 1 0 1 M 0 2 5 - _ _ _	38
188	7.33	48	1.99	3508	7 . 5				
131	10.50	68	2.00	3498	1 0 .				
110	12.50	78	1.77	3498	1 3 .				
95	14.50	90	1.57	3492	1 5 .				
69	20.00	113	1.51	3486	2 0 .				
55	25.00	137	1.25	3471	2 5 .				
46	30.00	158	1.04	3465	3 0 .				
188	7.33	49	3.06	6109	A 0 6 1 0 7 . 5 _ M _ - _ _ 1 . 1 4 A _	33.8	90S	X 6 1 1 0 1 M 0 2 8 - _ _ _	38
143	9.67	64	2.72	6064	1 0 .				
110	12.50	80	2.77	6013	1 3 .			X 6 1 1 0 2 M 0 2 8 - _ _ _	42
92	15.00	94	2.38	5970	1 5 .				
69	20.00	117	2.39	5898	2 0 .			X 6 1 1 0 3 M 0 2 8 - _ _ _	48
55	25.00	141	1.97	5863	2 5 .				
46	30.00	162	1.60	5790	3 0 .			X 6 1 1 0 2 M 0 2 8 - _ _ _	42
35	40.00	203	1.19	5695	4 0 .				
28	50.00	238	0.93	5600	5 0 .				
134	10.33	71	3.82	6988	A 0 7 3 0 1 0 . _ M _ - _ _ 1 . 1 4 A _	46.8	90S	X 6 1 1 0 2 M 0 3 0 - _ _ _	42
95	14.50	96	3.65	6979	1 5 .			X 6 1 1 0 3 M 0 3 0 - _ _ _	48
71	19.50	126	2.73	6970	2 0 .				
55	25.00	152	2.74	6964	2 5 .				
46	30.00	178	2.32	6957	3 0 .				
35	40.00	226	1.70	6926	4 0 .				
28	50.00	271	1.33	6910	5 0 .				
23	60.00	307	1.02	6894	6 0 .				
55	25.00	154	3.93	8860	A 0 8 6 0 2 5 . _ M _ - _ _ 1 . 1 4 A _	63.8	90S	X 6 1 1 0 4 M 0 3 5 - _ _ _	60
46	30.00	181	3.51	8860	3 0 .				
35	40.00	231	2.57	8860	4 0 .				
28	50.00	274	1.95	8860	5 0 .				
23	60.00	314	1.56	8850	6 0 .				
20	70.00	344	1.17	8840	7 0 .			X 6 1 1 0 3 M 0 3 5 - _ _ _	48
192	4.80	49	2.27	3510	A 0 5 1 0 5 . 0 _ M _ - _ _ 1 . 1 6 A _	32.5	90L	X 6 1 1 0 1 M 0 2 5 - _ _ _	38
125	7.33	72	1.58	3500	7 . 5				
88	10.50	100	1.58	3490	1 0 .				
74	12.50	116	1.39	3480	1 3 .				
63	14.50	134	1.12	3470	1 5 .				
46	20.00	167	1.18	3460	2 0 .			X 6 1 1 0 2 M 0 2 5 - _ _ _	42
37	25.00	199	0.99	3450	2 5 .				
31	30.00	231	0.82	3430	3 0 .				
184	5.00	51	3.41	6130	A 0 6 1 0 5 . 0 _ M _ - _ _ 1 . 1 6 A _	38.5	90L	X 6 1 1 0 1 M 0 2 8 - _ _ _	38
125	7.33	74	2.43	6062	7 . 5				
95	9.67	95	2.14	5974	1 0 .			X 6 1 1 0 2 M 0 2 8 - _ _ _	42
74	12.50	119	2.18	5878	1 3 .				
61	15.00	139	1.86	5794	1 5 .				
46	20.00	172	1.74	5663	2 0 .			X 6 1 1 0 3 M 0 2 8 - _ _ _	48
37	25.00	205	1.57	5523	2 5 .				
31	30.00	237	1.26	5471	3 0 .				
23	40.00	296	0.93	5280	4 0 .				
127	7.25	75	3.66	6988	A 0 7 3 0 7 . 5 _ M _ - _ _ 1 . 1 6 A _	51.5	90L	X 6 1 1 0 2 M 0 3 0 - _ _ _	42
89	10.33	105	3.01	6976	1 0 .			X 6 1 1 0 3 M 0 3 0 - _ _ _	48
74	12.50	125	3.21	6968	1 3 .				
63	14.50	143	2.87	6960	1 5 .				
47	19.50	187	2.13	6944	2 0 .				
37	25.00	224	2.16	6928	2 5 .			X 6 1 1 0 4 M 0 3 0 - _ _ _	60
31	30.00	262	1.83	6916	3 0 .				
23	40.00	333	1.32	6876	4 0 .			X 6 1 1 0 3 M 0 3 0 - _ _ _	48
18	50.00	399	1.04	6850	5 0 .				
47	19.50	189	3.21	8848	A 0 8 6 0 2 0 . _ M _ - _ _ 1 . 1 6 A _	68.5	90L	X 6 1 1 0 4 M 0 3 5 - _ _ _	60
37	25.00	227	3.09	8843	2 5 .				
31	30.00	266	2.77	8056	3 0 .			X 6 1 1 0 5 M 0 3 5 - _ _ _	70
23	40.00	338	2.02	8833	4 0 .			X 6 1 1 0 4 M 0 3 5 - _ _ _	60
18	50.00	402	1.52	8826	5 0 .				
15	60.00	455	1.12	8812	6 0 .				
13	70.00	500	0.84	8790	7 0 .				

NOTE

Other output speeds are available using 2 and 8 pole motors - Please contact our Application Engineers

SELECTION TABLES GEARED MOTORS

1.5 kW

4 POLE

6 POLE

N2 R/MIN	i	M2 Nm	Fm	N	UNIT DESIGNATION	Kg			
Output Speed	Ratio	Output Torque	Service Factor	Overhung Load	Column Entry <input type="text" value="1"/> Through <input type="text" value="20"/> Spaces to be filled when entering order	Weight of Base Mount Unit	Motor Frame Size	Cone Ring Output Coupling Spaces to be filled when entering order	Max Bore Coupling Drive Half
290	4.80	44	2.08	3510	A 0 5 1 0 5 . 0 _ M _ _ _ 1 . 5 4 A _	30.0	90L	X 6 1 1 0 1 M 0 2 5 - _ _ _	38
190	7.33	66	1.47	3500	7 . 5				
132	10.50	92	1.48	3490	1 0 .				
111	12.50	106	1.30	3490	1 3 .				
96	14.50	122	1.16	3480	1 5 .				
70	20.00	153	1.11	3470	2 0 .				
56	25.00	185	0.93	3450	2 5 .			X 6 1 1 0 2 M 0 2 5 - _ _ _	42
278	5.00	46	3.13	6130	A 0 6 1 0 5 . 0 _ M _ _ _ 1 . 5 4 A _	36.0	90L	X 6 1 1 0 1 M 0 2 8 - _ _ _	38
190	7.33	67	2.26	6095	7 . 5				
144	9.67	87	2.01	6017	1 0 .				
111	12.50	109	2.05	5928	1 3 .			X 6 1 1 0 2 M 0 2 8 - _ _ _	42
93	15.00	128	1.76	5854	1 5 .				
70	20.00	159	1.76	5730	2 0 .			X 6 1 1 0 3 M 0 2 8 - _ _ _	48
56	25.00	192	1.46	5669	2 5 .				
46	30.00	219	1.18	5542	3 0 .			X 6 1 1 0 2 M 0 2 8 - _ _ _	42
35	40.00	275	0.88	5380	4 0 .				
192	7.25	68	3.41	6988	A 0 7 3 0 7 . 5 _ M _ _ _ 1 . 5 4 A _	49.0	90L	X 6 1 1 0 2 M 0 3 0 - _ _ _	42
135	10.33	96	2.82	6980	1 0 .				
111	12.50	113	3.03	6972	1 3 .			X 6 1 1 0 3 M 0 3 0 - _ _ _	48
96	14.50	131	2.70	6965	1 5 .				
71	19.50	171	2.01	6949	2 0 .				
56	25.00	206	2.03	6937	2 5 .				
46	30.00	242	1.71	6926	3 0 .				
35	40.00	306	1.25	6887	4 0 .				
28	50.00	367	0.98	6860	5 0 .				
71	19.50	173	3.03	8850	A 0 8 6 0 2 0 . _ M _ _ _ 1 . 5 4 A _	66.0	90L	X 6 1 1 0 4 M 0 3 5 - _ _ _	60
56	25.00	208	2.90	8847	2 5 .				
46	30.00	245	2.59	8846	3 0 .				
35	40.00	312	1.90	8841	4 0 .				
28	50.00	372	1.44	8830	5 0 .				
23	60.00	425	1.15	8817	6 0 .				
20	70.00	465	0.86	8810	7 0 .				
190	5.00	67	2.58	6130	A 0 6 1 0 5 . 0 _ M _ _ _ 1 . 5 6 A _	43.2	100La	X 6 1 1 0 1 M 0 2 8 - _ _ _	38
130	7.33	97	1.84	6025	7 . 5				
98	9.67	125	1.62	5889	1 0 .			X 6 1 1 0 2 M 0 2 8 - _ _ _	42
76	12.50	157	1.65	5740	1 3 .				
63	15.00	184	1.41	5611	1 5 .				
48	20.00	227	1.32	5407	2 0 .			X 6 1 1 0 3 M 0 2 8 - _ _ _	48
38	25.00	272	1.19	5191	2 5 .				
32	30.00	313	0.96	5110	3 0 .				
183	5.20	72	3.66	6987	A 0 7 3 0 5 . 0 _ M _ _ _ 1 . 5 6 A _	56.2	100La	X 6 1 1 0 2 M 0 3 0 - _ _ _	42
131	7.25	99	2.77	6981	7 . 5				
92	10.33	139	2.28	6962	1 0 .			X 6 1 1 0 3 M 0 3 0 - _ _ _	48
76	12.50	165	2.43	6950	1 3 .				
66	14.50	189	2.17	6938	1 5 .				
49	19.50	247	1.62	6913	2 0 .				
38	25.00	296	1.64	6888	2 5 .			X 6 1 1 0 4 M 0 3 0 - _ _ _	60
32	30.00	346	1.39	6870	3 0 .				
24	40.00	439	1.00	6820	4 0 .			X 6 1 1 0 3 M 0 3 0 - _ _ _	48
98	9.67	132	3.68	8853	A 0 8 6 0 1 0 . _ M _ _ _ 1 . 5 6 A _	73.2	100La	X 6 1 1 0 4 M 0 3 5 - _ _ _	60
75	12.67	170	3.31	8848	1 3 .				
66	14.50	191	3.29	8843	1 5 .				
49	19.50	250	2.43	8834	2 0 .				
38	25.00	300	2.34	8825	2 5 .				
32	30.00	352	2.10	7138	3 0 .			X 6 1 1 0 5 M 0 3 5 - _ _ _	70
24	40.00	446	1.53	8803	4 0 .			X 6 1 1 0 4 M 0 3 5 - _ _ _	60
19	50.00	530	1.15	8787	5 0 .				
16	60.00	601	0.85	8770	6 0 .				

NOTE

Other output speeds are available using 2 and 8 pole motors - Please contact our Application Engineers

SERIES AJ

SELECTION TABLES GEARED MOTORS

2.2 kW

4 POLE

6 POLE

N2 R/MIN	i	M2 Nm	Fm	N	UNIT DESIGNATION	Kg			
Output Speed	Ratio	Output Torque	Service Factor	Overhung Load	Column Entry 1 Through 20 Spaces to be filled when entering order	Weight of Base Mount Unit	Motor Frame Size	Cone Ring Output Coupling Spaces to be filled when entering order	Max Bore Coupling Drive Half
282	5.00	67	2.17	6130	A 0 6 1 0 5 . 0 _ M _ _ _ 2 . 2 4 A _	43.0	100La	X 6 1 1 0 1 M 0 2 8 - _ _ _	38
192	7.33	97	1.56	6069	7 . 5				
146	9.67	126	1.39	5934	1 0 .				
113	12.50	158	1.41	5779	1 3 .			X 6 1 1 0 2 M 0 2 8 - _ _ _	42
94	15.00	185	1.22	5651	1 5 .				
71	20.00	230	1.22	5436	2 0 .			X 6 1 1 0 3 M 0 2 8 - _ _ _	48
56	25.00	277	1.01	5330	2 5 .				
47	30.00	317	0.82	5110	3 0 .				
271	5.20	72	3.09	6993	A 0 7 3 0 5 . 0 _ M _ _ _ 2 . 2 4 A _	56.0	100La	X 6 1 1 0 2 M 0 3 0 - _ _ _	42
194	7.25	99	2.36	6979	7 . 5				
136	10.33	139	1.95	6966	1 0 .				
113	12.50	164	2.10	6952	1 3 .			X 6 1 1 0 3 M 0 3 0 - _ _ _	48
97	14.50	189	1.87	6939	1 5 .				
72	19.50	247	1.39	6912	2 0 .				
56	25.00	298	1.40	6892	2 5 .				
47	30.00	350	1.18	6872	3 0 .				
35	40.00	443	0.87	6820	4 0 .				
194	7.25	100	3.59	8856	A 0 8 6 0 7 . 5 _ M _ _ _ 2 . 2 4 A _	73.0	100La	X 6 1 1 0 3 M 0 3 5 - _ _ _	48
146	9.67	131	3.16	8851	1 0 .				
111	12.67	170	2.84	8844	1 3 .			X 6 1 1 0 4 M 0 3 5 - _ _ _	60
97	14.50	191	2.83	8842	1 5 .				
72	19.50	250	2.10	8835	2 0 .				
56	25.00	301	2.01	8825	2 5 .				
47	30.00	355	1.79	8822	3 0 .				
35	40.00	452	1.31	8807	4 0 .				
28	50.00	537	0.99	8780	5 0 .				
189	5.00	100	1.75	6130	A 0 6 1 0 5 . 0 _ M _ _ _ 2 . 2 6 A _	50.8	112M	X 6 1 1 0 1 M 0 2 8 - _ _ _	38
129	7.33	144	1.25	5960	7 . 5				
98	9.67	185	1.10	5740	1 0 .			X 6 1 1 0 2 M 0 2 8 - _ _ _	42
76	12.50	232	1.12	5500	1 3 .				
63	15.00	272	0.96	5290	1 5 .				
47	20.00	335	0.89	4960	2 0 .			X 6 1 1 0 3 M 0 2 8 - _ _ _	48
38	25.00	401	0.81	4610	2 5 .				
182	5.20	107	2.48	6980	A 0 7 3 0 5 . 0 _ M _ _ _ 2 . 2 6 A _	63.8	112M	X 6 1 1 0 2 M 0 3 0 - _ _ _	42
130	7.25	147	1.88	6970	7 . 5				
91	10.33	206	1.54	6940	1 0 .			X 6 1 1 0 3 M 0 3 0 - _ _ _	48
76	12.50	244	1.65	6920	1 3 .				
65	14.50	279	1.47	6900	1 5 .				
48	19.50	364	1.10	6860	2 0 .				
38	25.00	437	1.11	6820	2 5 .			X 6 1 1 0 4 M 0 3 0 - _ _ _	60
32	30.00	510	0.94	6790	3 0 .				
130	7.25	148	2.86	8860	A 0 8 6 0 7 . 5 _ M _ _ _ 2 . 2 6 A _	80.8	112M	X 6 1 1 0 3 M 0 3 5 - _ _ _	48
98	9.67	194	2.50	8846	1 0 .			X 6 1 1 0 4 M 0 3 5 - _ _ _	60
75	12.67	251	2.24	8837	1 3 .				
65	14.50	282	2.23	8828	1 5 .				
48	19.50	368	1.65	8810	2 0 .				
38	25.00	442	1.59	8793	2 5 .				
32	30.00	519	1.42	5531	3 0 .			X 6 1 1 0 5 M 0 3 5 - _ _ _	70
24	40.00	658	1.04	8750	4 0 .			X 6 1 1 0 4 M 0 3 5 - _ _ _	60

NOTE

Other output speeds are available using 2 and 8 pole motors - Please contact our Application Engineers

SERIES AJ

SELECTION TABLES GEARED MOTORS

3.0 kW

4 POLE

6 POLE

N2 R/MIN	i	M2 Nm	Fm	N	UNIT DESIGNATION	Kg			
Output Speed	Ratio	Output Torque	Service Factor	Overhung Load	Column Entry 1 Through 20 Spaces to be filled when entering order	Weight of Base Mount Unit	Motor Frame Size	Cone Ring Output Coupling Spaces to be filled when entering order	Max Bore Coupling Drive Half
284	5.00	91	1.60	6130	A 0 6 1 0 5 . 0 _ M _ - _ _ 3 . 0 4 A _	46.8	100Lb	X 6 1 1 0 1 M 0 2 8 - _ _ _	38
194	7.33	131	1.16	6040	7 . 5				
147	9.67	170	1.03	5840	1 0 .				
114	12.50	214	1.04	5610	1 3 .			X 6 1 1 0 2 M 0 2 8 - _ _ _	42
95	15.00	250	0.90	5420	1 5 .				
71	20.00	311	0.90	5100	2 0 .			X 6 1 1 0 3 M 0 2 8 - _ _ _	48
273	5.20	97	2.28	6990	A 0 7 3 0 5 . 0 _ M _ - _ _ 3 . 0 4 A _	59.8	100Lb	X 6 1 1 0 2 M 0 3 0 - _ _ _	42
196	7.25	134	1.74	6970	7 . 5				
137	10.33	188	1.44	6950	1 0 .				
114	12.50	222	1.55	6930	1 3 .			X 6 1 1 0 3 M 0 3 0 - _ _ _	48
98	14.50	256	1.38	6910	1 5 .				
73	19.50	335	1.03	6870	2 0 .				
57	25.00	403	1.03	6840	2 5 .				
47	30.00	474	0.87	6810	3 0 .			X 6 1 1 0 4 M 0 3 0 - _ _ _	60
294	4.83	91	3.95	8860	A 0 8 6 0 5 . 0 _ M _ - _ _ 3 . 0 4 A _	76.8	100Lb	X 6 1 1 0 3 M 0 3 5 - _ _ _	48
196	7.25	135	2.65	8854	7 . 5				
147	9.67	177	2.33	8845	1 0 .				
112	12.67	230	2.10	8833	1 3 .			X 6 1 1 0 4 M 0 3 5 - _ _ _	60
98	14.50	258	2.09	8830	1 5 .				
73	19.50	339	1.55	8816	2 0 .				
57	25.00	408	1.48	8799	2 5 .				
47	30.00	481	1.33	8794	3 0 .				
36	40.00	612	0.97	8770	4 0 .				
197	4.83	136	3.19	8860	A 0 8 6 0 5 . 0 _ M _ - _ _ 3 . 0 6 A _	93.0	132Sa	X 6 1 1 0 3 M 0 3 5 - _ _ _	48
131	7.25	201	2.11	8860	7 . 5				
98	9.67	264	1.84	8839	1 0 .			X 6 1 1 0 4 M 0 3 5 - _ _ _	60
75	12.67	341	1.65	8825	1 3 .				
66	14.50	383	1.65	8811	1 5 .				
49	19.50	500	1.22	8783	2 0 .				
38	25.00	600	1.17	8756	2 5 .				
32	30.00	704	1.05	3695	3 0 .			X 6 1 1 0 5 M 0 3 5 - _ _ _	70

NOTE
Other output speeds are available using 2 and 8 pole motors - Please contact our Application Engineers

SERIES AJ

SELECTION TABLES GEARED MOTORS

4.0 kW

4 POLE

6 POLE

N2 R/MIN	i	M2 Nm	Fm	N	UNIT DESIGNATION	Kg			
Output Speed	Ratio	Output Torque	Service Factor	Overhung Load	Column Entry <input type="text" value="1"/> Through <input type="text" value="20"/> Spaces to be filled when entering order	Weight of Base Mount Unit	Motor Frame Size	Cone Ring Output Coupling Spaces to be filled when entering order	Max Bore Coupling Drive Half
295	4.83	121	2.97	8860	A 0 8 6 0 5 . 0 _ M _ - _ - 4 . 0 4 A _	83.0	112M	X 6 1 1 0 3 M 0 3 5 - _ - -	48
197	7.25	179	2.00	8850	7 . 5				
147	9.67	236	1.75	8837	1 0 .				
113	12.67	306	1.58	8819	1 3 .				
98	14.50	344	1.57	8814	1 5 .			X 6 1 1 0 4 M 0 3 5 - _ - -	60
73	19.50	450	1.16	8794	2 0 .				
57	25.00	542	1.12	8767	2 5 .				
48	30.00	639	1.00	8760	3 0 .				
198	4.83	180	2.40	8860	A 0 8 6 0 5 . 0 _ M _ - _ - 4 . 0 6 A _	102.0	132Ma	X 6 1 1 0 3 M 0 3 5 - _ - -	48
132	7.25	267	1.59	8860	7 . 5				
99	9.67	350	1.39	8830	1 0 .				
75	12.67	452	1.25	8810	1 3 .				
66	14.50	508	1.24	8790	1 5 .			X 6 1 1 0 4 M 0 3 5 - _ - -	60
49	19.50	663	0.92	8750	2 0 .				
38	25.00	796	0.88	8710	2 5 .				

NOTE
Other output speeds are available using 2 and 8 pole motors - Please contact our Application Engineers

SERIES AJ

SELECTION TABLES GEARED MOTORS

5.5 kW		N2 R/MIN	i	M2 Nm	Fm	N	UNIT DESIGNATION	Kg			
4 POLE	Output Speed	Ratio	Output Torque	Service Factor	Overhung Load	Column Entry 1 Through 20 Spaces to be filled when entering order	Weight of Base Mount Unit	Motor Frame Size	Cone Ring Output Coupling Spaces to be filled when entering order	Max Bore Coupling Drive Half	
	300	4.83	164	2.20	8860	A 0 8 6 0 5 . 0 _ M _ - _ - 5 . 5 4 A _	96.0	132Sa	X 6 1 1 0 3 M 0 3 5 - _ - -	48	
	200	7.25	243	1.48	8846	7 . 5					
	150	9.67	318	1.30	8825	1 0 .			X 6 1 1 0 4 M 0 3 5 - _ - -	60	
	114	12.67	413	1.17	8798	1 3 .					
	100	14.50	464	1.16	8791	1 5 .					
	74	19.50	609	0.86	8760	2 0 .					
	58	25.00	732	0.83	8720	2 5 .			X 6 1 1 0 5 M 0 3 5 - _ - -	70	
7.5 kW											
4 POLE	300	4.83	224	1.61	8860	A 0 8 6 0 5 . 0 _ M _ - _ - 7 . 5 4 A _	106.0	132Ma	X 6 1 1 0 3 M 0 3 5 - _ - -	48	
	200	7.25	331	1.08	8840	7 . 5					
	150	9.67	434	0.95	8810	1 0 .					
	114	12.67	564	0.86	8770	1 3 .			X 6 1 1 0 4 M 0 3 5 - _ - -	60	
	100	14.50	633	0.85	8760	1 5 .					

NOTE

Other output speeds are available using 2 and 8 pole motors - Please contact our Application Engineers

SERIES AJ

DIMENSIONS

SINGLE REDUCTION

A 0 0 0 0 W M

STANDARD UNIT

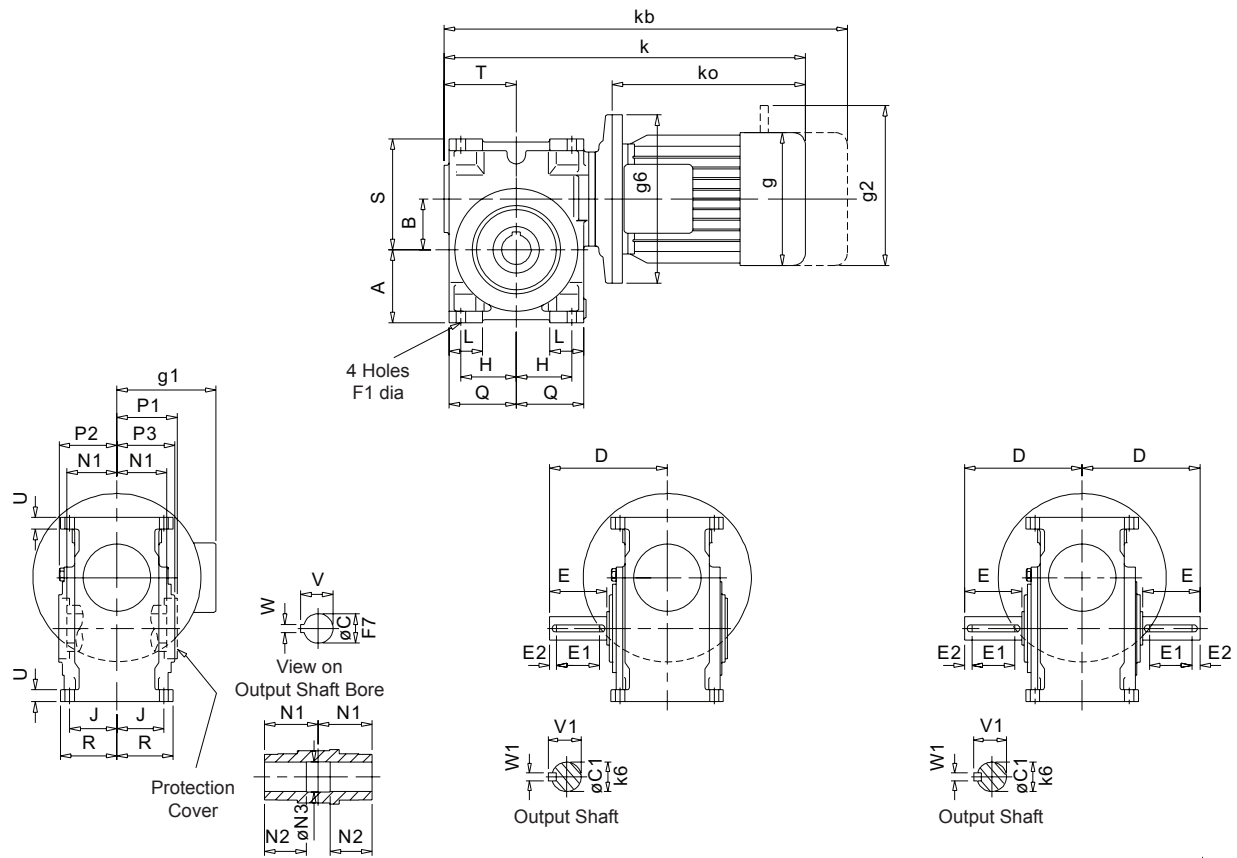

SIZE	A	B	øC	øC1	D	E	E1	E2	F1	H	J	L	N1	N2
A0280	58	28.6	16	16	79	35	23	5.5	9	52.5	41.5	30	40	32
A0410	66	41.3	22	20	98	45	34	6	11.5	58.5	49	32	50	40
A0510	74	50.8	25	25	117	57	42	7	11.5	57	52	35	56	45
A0610	87	60.3	35	28	140	70	55	7	11.5	66	56	40	64	50
A0730	105	73.0	40	30	168	83	62	7	13.5	81	70	45	77	60
A0860	117	85.7	50	35	200	98	80	8	17.5	90	79	55	93	73

SIZE	.N3	P1	P2	P3	Q	R	S	T	U	V	V1	W	W1
A0280	16.2	48	45	44	61.5	50.5	81	53	9	18.4 18.3	18.00 17.87	5.015 4.985	5.000 4.970
A0410	22.2	58	55	55	69	60	101	62	10	24.9 24.8	22.50 22.37	6.015 5.985	6.000 5.970
A0510	25.2	63	61	61	67	62	112	75	12	28.5 28.3	28.00 27.71	8.018 7.982	8.000 7.964
A0610	35.2	79	67	69	80	67	132	86	14	38.5 38.3	31.00 30.71	10.018 9.982	8.000 7.964
A0730	40.2	95	81	84	95	84	153	103	16	43.5 43.3	33.00 32.71	12.021 11.979	8.000 7.964
A0860	50.2	104	97	99	108	97	178	116	18	54.0 53.8	38.00 27.71	14.021 13.979	10.000 9.964

MOTORS		ALL SIZES					A0280	A0410	A0510	A0610	A0730	A0860				
		ko	g	g1	g2	g6	k	kb	k	kb	k	kb	k	kb	k	kb
MOTOR FRAME SIZE	63	185	122	101	160	140	314	356	-	-	-	-	-	-	-	-
	71	210	137	107	167	160	340	381	354	395	385	426	-	-	-	-
	80	230	158	118	190	200	-	-	379	429	405	455	430	480	471	521
	90S/L	270	177	149	218	200	-	-	-	-	445	504	470	529	511	570
	100/112	340	197	159	238	250	-	-	-	-	-	-	544	612	581	649
	132	402	253	184	288	300	-	-	-	-	-	-	-	-	-	676 747

SERIES AJ

DIMENSIONS

SINGLE REDUCTION

A 0 0 F M STANDARD UNIT FLANGE MOUNTED

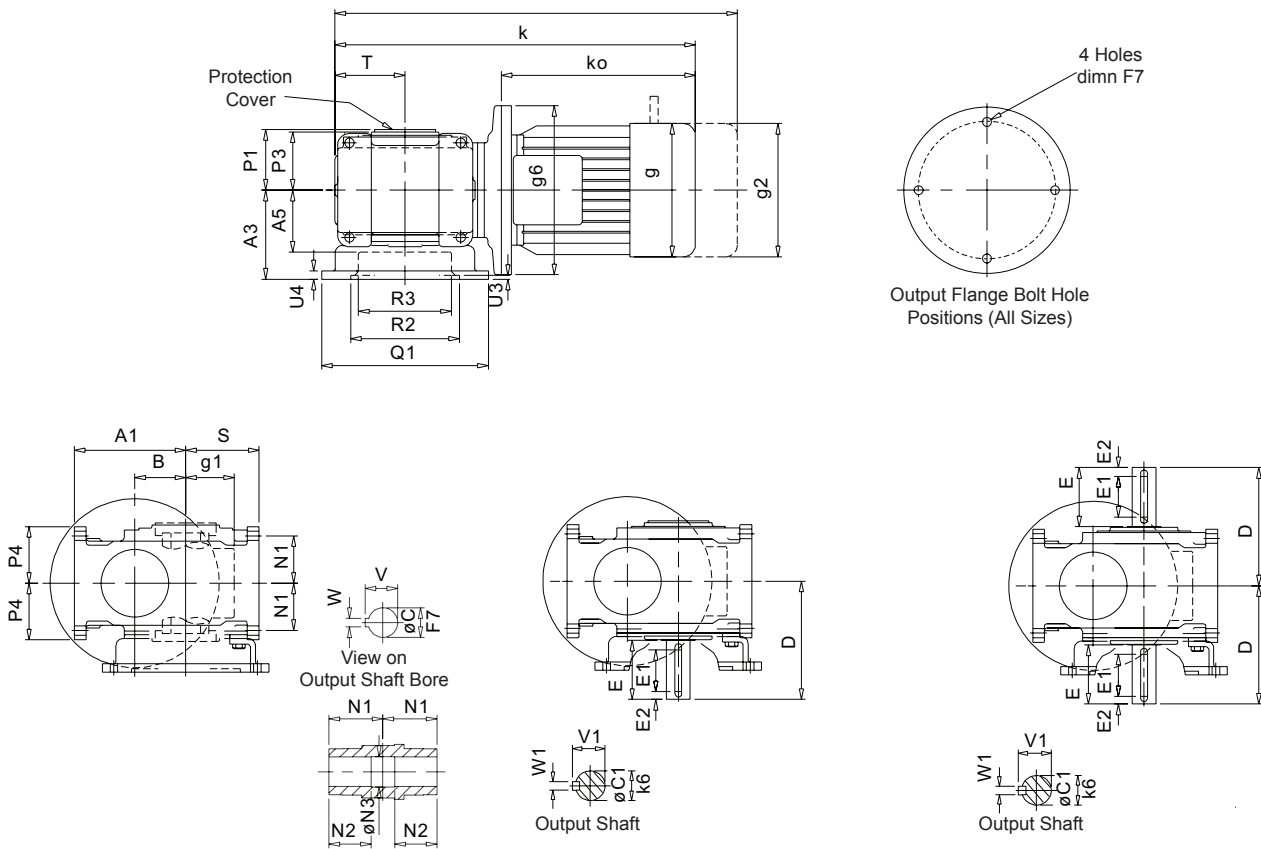

SIZE	A1	A3	A5	B	øC	øC1	D	E	E1	E2	F7	N1	N2	øN3
A0280	81	63	49	28.6	16	16	79	35	23	5.5	.6.6 on 100 PCD	40	32	16.2
A0410	101	80	60	41.3	22	20	98	45	34	6	.9 on 115 PCD	50	40	22.2
A0510	112	90	65	50.8	25	25	117	57	42	7	.9 on 130 PCD	56	45	25.2
A0610	132	105	71	60.3	35	28	140	70	55	7	.11 on 165 PCD	64	50	35.2
A0730	153	120	91	73.0	40	30	168	83	62	7	.13.5 on 215 PCD	77	60	40.2
A0860	178	132	100	85.7	50	35	200	98	80	8	.13.5 on 215 PCD	93	73	50.2

SIZE	P1	P3	P4	Q1	R2	R3	S	T	U3	U4	V	V1	W	W1
A0280	48	44	50.5	120	80.030 80.000	60	58	53	3	7	18.4 18.3	18.00 17.87	5.015 4.985	5.000 4.970
A0410	58	55	60	140	95.035 95.000	72	66	62	3.5	8	24.9 24.8	22.50 22.37	6.015 5.985	6.000 5.970
A0510	63	61	62	160	110.035 110.000	88	74	75	4	9	28.5 28.3	28.00 27.71	8.018 7.982	8.000 7.964
A0610	79	69	67	200	130.040 130.000	110	87	86	4.5	10	38.5 38.3	31.00 30.71	10.018 9.982	8.000 7.964
A0730	95	84	84	250	180.040 180.000	136	105	103	5	12	43.5 43.3	33.00 32.71	12.021 11.979	8.000 7.964
A0860	104	99	97	250	180.040 180.000	150	117	116	5	12	54.0 53.8	38.00 37.71	14.021 13.979	10.000 9.964

MOTORS		ALL SIZES					A0280		A0410		A0510		A0610		A0730		A0860	
		ko	g	g1	g2	g6	k	kb	k	kb	k	kb	k	kb	k	kb	k	kb
MOTOR FRAME SIZE	63	185	122	101	160	140	314	356	-	-	-	-	-	-	-	-	-	-
	71	210	137	107	167	160	340	381	354	395	385	426	-	-	-	-	-	-
	80	230	158	118	190	200	-	-	379	429	405	455	430	480	471	521	-	-
	90S/L	270	177	149	218	200	-	-	-	-	445	504	470	529	511	570	537	596
	100/112	340	197	159	238	250	-	-	-	-	-	-	544	612	581	649	607	675
	132	402	253	184	288	300	-	-	-	-	-	-	-	-	-	-	676	747

SERIES AJ

DIMENSIONS

SINGLE REDUCTION

A 0 0 0 0 G M

STANDARD UNIT SIDE MOUNTED FEET

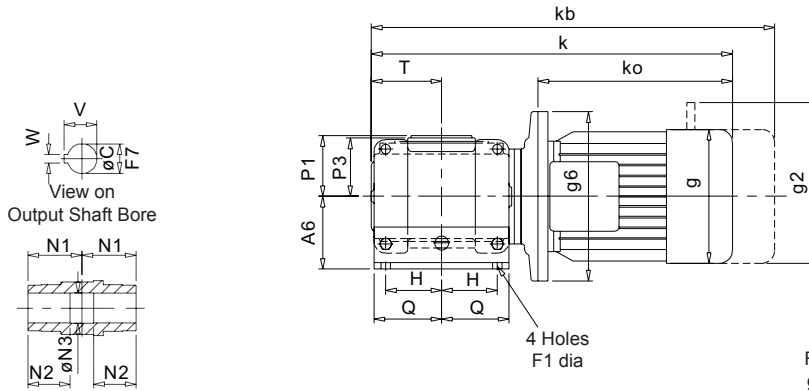

Feet can be fitted on either side of the gearcase as shown by the dotted line

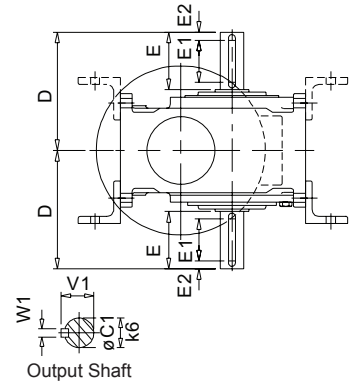
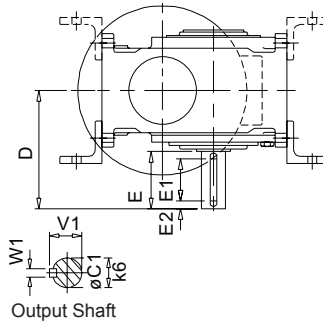
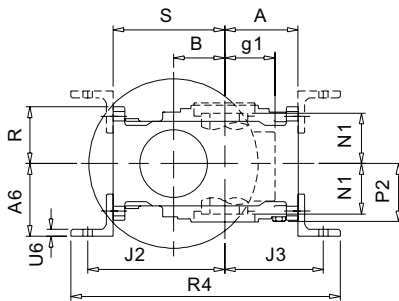

SIZE	A	A6	B	øC	øC1	D	E	E1	E2	F1	H	J2	J3	N1
A0280	58	62	28.6	16	16	79	35	23	5.5	9	52.5	101.5	78.5	40
A0410	66	75	41.3	22	20	98	45	34	6	11.5	58.5	127	92	50
A0510	74	78	50.8	25	25	117	57	42	7	11.5	57	138	100	56
A0610	87	86	60.3	35	28	140	70	55	7	11.5	66	162	117	64
A0730	105	103	73.0	40	30	168	83	62	7	13.5	81	186	138	77
A0860	117	118	85.7	50	35	200	98	80	8	17.5	90	217	156	93

SIZE	N2	øN3	P1	P2	P3	R	R4	S	T	U6	V	V1	W	W1
A0280	32	16.2	48	45	44	50.5	199	81	53	5	18.4 18.3	18.00 17.87	5.015 4.985	5.000 4.970
A0410	40	22.2	58	55	55	60	247	101	62	6	24.9 24.8	22.50 22.37	6.015 5.985	6.000 5.970
A0510	45	25.2	63	61	61	62	266	112	75	6	28.5 28.3	28.00 27.71	8.018 7.982	8.000 7.964
A0610	50	35.2	79	67	69	67	319	132	86	8	38.5 38.3	31.00 30.71	10.018 9.982	8.000 7.964
A0730	60	40.2	95	81	84	84	358	153	103	8	43.5 43.3	33.00 32.71	12.021 11.979	8.000 7.964
A0860	73	50.2	104	97	99	97	415	178	116	10	54.0 53.8	38.00 37.71	14.021 13.979	10.000 9.964

MOTORS		ALL SIZES					A0280		A0410		A0510		A0610		A0730		A0860	
		ko	g	g1	g2	g6	k	kb	k	kb	k	kb	k	kb	k	kb	k	kb
MOTOR FRAME SIZE	63	185	122	101	160	140	314	356	-	-	-	-	-	-	-	-	-	-
	71	210	137	107	167	160	340	381	354	395	385	426	-	-	-	-	-	-
	80	230	158	118	190	200	-	-	379	429	405	455	430	480	471	521	-	-
	90S/L	270	177	149	218	200	-	-	-	-	445	504	470	529	511	570	537	596
	100/112	340	197	159	238	250	-	-	-	-	-	-	544	612	581	649	607	675
	132	402	253	184	288	300	-	-	-	-	-	-	-	-	-	-	-	676 747

SERIES AJ

DIMENSIONS

SINGLE REDUCTION

A 0 0 H M STANDARD UNIT END MOUNTED FEET

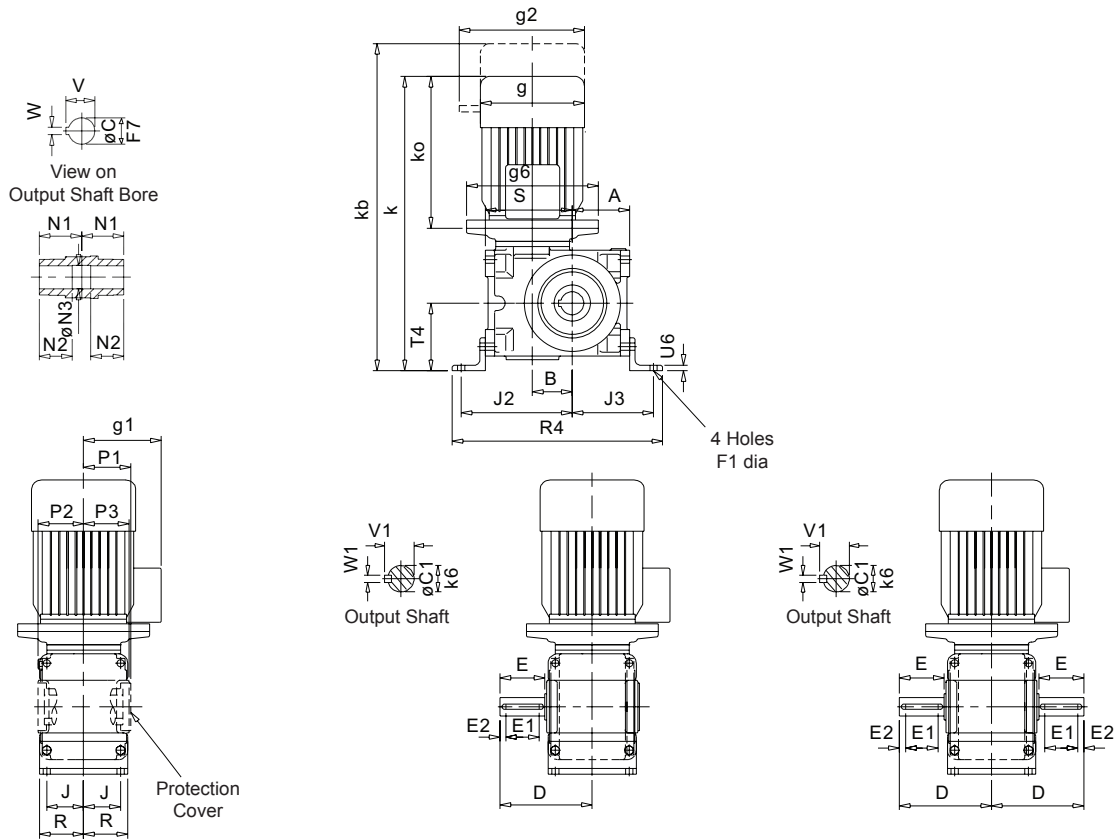

SIZE	A	B	$\varnothing C$	$\varnothing C1$	D	E	E1	E2	F1	J	J2	J3	N1	N2
A0280	58	28.6	16	16	79	35	23	5.5	9	41.5	101.5	78.5	40	32
A0410	66	41.3	22	20	98	45	34	6	11.5	49	127	92	50	40
A0510	74	50.8	25	25	117	57	42	7	11.5	52	138	100	56	45
A0610	87	60.3	35	28	140	70	55	7	11.5	56	162	117	64	50
A0730	105	73.0	40	30	168	83	62	7	13.5	70	186	138	77	60
A0860	117	85.7	50	35	200	98	80	8	17.5	79	217	156	93	73

SIZE	$\varnothing N3$	P1	P2	P3	R	R4	S	T4	U6	V	V1	W	W1
A0280	16.2	48	45	44	50.5	199	81	73	5	18.4 18.3	18.00 17.87	5.015 4.985	5.000 4.970
A0410	22.2	58	55	55	60	247	101	84.5	6	24.9 24.8	22.50 22.37	6.015 5.985	6.000 5.970
A0510	25.2	63	61	61	62	266	112	83	6	28.5 28.3	28.00 27.71	8.018 7.982	8.000 7.964
A0610	35.2	79	67	69	67	319	132	96	8	38.5 38.3	31.00 30.71	10.018 9.982	8.000 7.964
A0730	40.2	95	81	84	84	358	153	114	8	43.5 43.3	33.00 32.71	12.021 11.979	8.000 7.964
A0860	50.2	104	97	99	97	415	178	129	10	54.0 53.8	38.00 37.71	14.021 13.979	10.000 9.964

MOTORS		ALL SIZES					A0280		A0410		A0510		A0610		A0730		A0860	
		ko	g	g1	g2	g6	k	kb	k	kb	k	kb	k	kb	k	kb	k	kb
MOTOR FRAMESIZE	63	185	122	101	160	140	334	376	-	-	-	-	-	-	-	-	-	-
	71	210	137	107	167	160	360	401	376.5	417.5	393	434	-	-	-	-	-	-
	80	230	158	118	190	200	-	-	401.5	451.5	413	463	440	490	482	532	-	-
	90S/L	270	177	149	218	200	-	-	-	-	453	512	480	539	522	581	550	609
	100/112	340	197	159	238	250	-	-	-	-	-	-	544	622	592	660	620	688
	132	402	253	184	288	300	-	-	-	-	-	-	-	-	-	-	-	689 760

SERIES AJ

DIMENSIONS

DOUBLE REDUCTION

A 0 0 0 0 W N

STANDARD UNIT

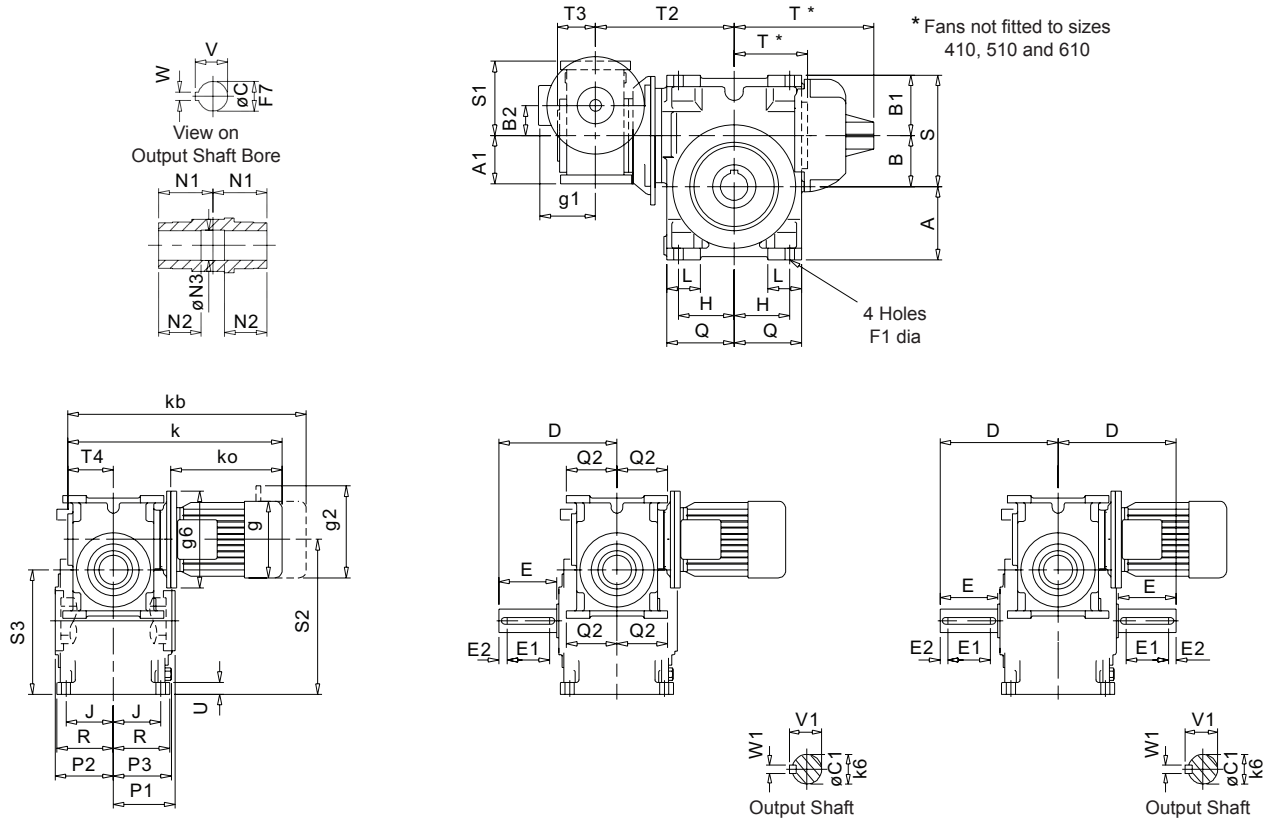

SIZE	A	A1	B	B1	B2	øC	øC1	D	E	E1	E2	F1	H	J	L	N1	N2	øN3	P1
A0410	66	58	41.3	59.7	28.6	22	20	98	45	34	6	11.5	58.5	49	32	50	40	22.2	58
A0510	74	58	50.8	61.2	28.6	25	25	117	57	42	7	11.5	57	52	35	56	45	25.2	63
A0610	87	66	60.3	71.7	41.3	35	28	140	70	55	7	11.5	66	56	40	64	50	35.2	79
A0730	105	66	73.0	80	41.3	40	30	168	83	62	7	13.5	81	70	45	77	60	40.2	95
A0860	117	74	85.7	92.3	50.8	50	35	200	98	80	8	17.5	90	79	55	93	73	50.2	104

SIZE	P2	P3	Q	Q2	R	S	S1	S2	S3	T	T2	T3	T4	U	V	V1	W	W1
A0410	55	55	69	61.5	60	101	81	135.9	107.3	62	126	48	53	10	24.9 24.8	22.50 22.37	6.015 5.985	6.000 5.970
A0510	61	61	67	61.5	62	112	81	153.4	124.8	75	143	48	53	12	28.5 28.3	28.00 27.71	8.018 7.982	8.000 7.964
A0610	69	67	80	69	67	132	101	188.6	147.3	86	171	58	62	14	38.5 38.3	31.00 30.71	10.018 9.982	8.000 7.964
A0730	84	81	95	69	84	153	101	219.6	178	197	192	58	62	16	43.5 43.3	33.00 32.71	12.021 11.979	8.000 7.964
A0860	99	97	108	67	97	178	112	253.5	202.7	227	208	63	75	18	54.0 53.8	38.00 37.71	14.021 13.979	10.000 9.964

MOTORS		ALL SIZES					A0410		A0510		A0610		A0730		A0860	
		ko	g	g1	g2	g6	k	kb	k	kb	k	kb	k	kb	k	kb
MOTOR FRAME SIZE	63	185	122	101	160	140	314	356	314	356	-	-	-	-	-	-
	71	210	137	107	167	160	340	381	340	381	354	395	354	395	385	426
	80	230	158	118	190	200	-	-	-	-	379	429	379	429	405	455
	90S/L	270	177	149	218	200	-	-	-	-	-	-	-	-	445	504

SERIES AJ

DIMENSIONS

DOUBLE REDUCTION

A 0 0 F N

STANDARD UNIT FLANGE MOUNTED

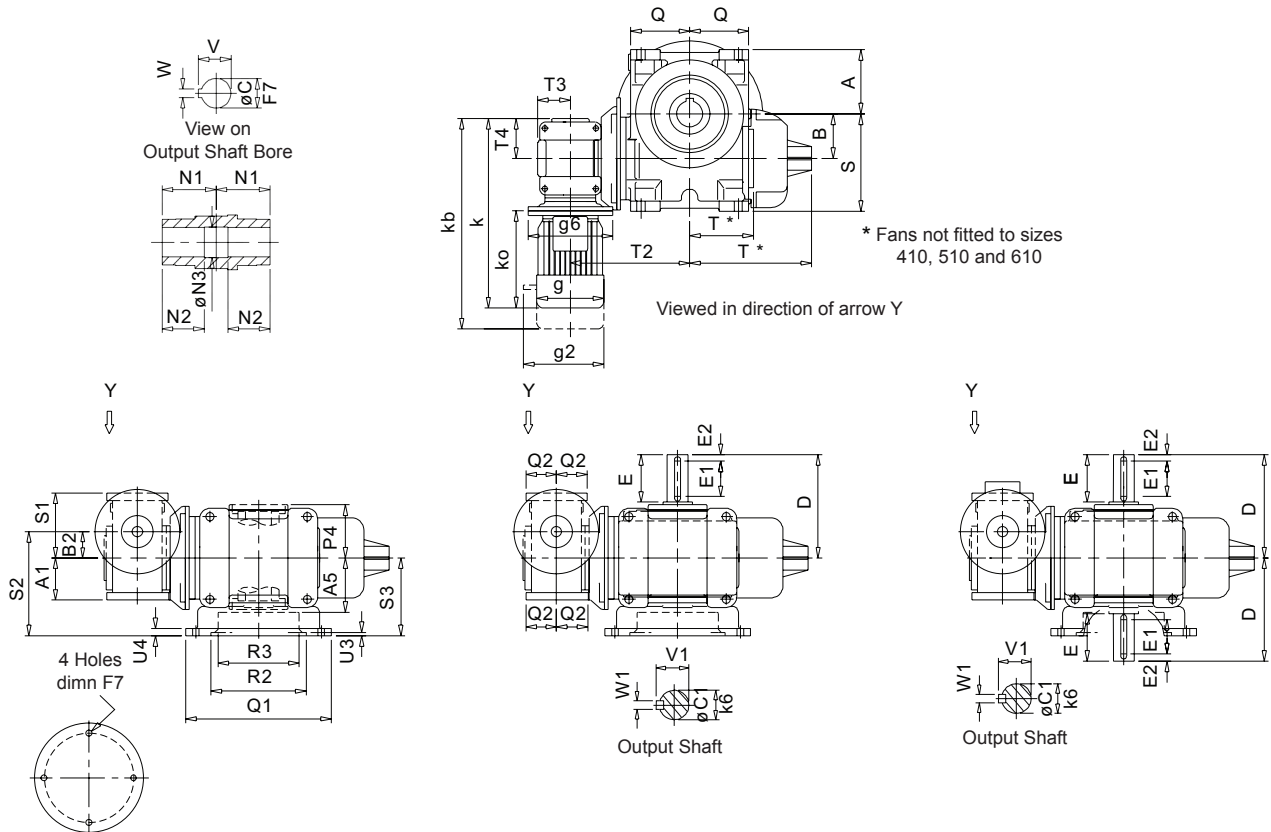

Output Flange Bolt Hole Positions (All Sizes)

SIZE	A	A1	A5	B	B2	øC	øC1	D	E	E1	E2	F7	N1	N2	øN3	P4	Q	Q1
A0410	66	58	60	41.3	28.6	22	20	98	45	34	6	ø9 on 115 PCD	50	40	22.2	55	69	140
A0510	74	58	65	50.8	28.6	25	25	117	57	42	7	ø9 on 130 PCD	56	45	25.2	61	67	160
A0610	87	66	71	60.3	41.3	35	28	140	70	55	7	ø11 on 165 PCD	64	50	35.2	69	80	200
A0730	105	66	91	73.0	41.3	40	30	168	83	62	7	ø13.5 on 215 PCD	77	60	40.2	84	95	250
A0860	117	74	100	85.7	50.8	50	35	200	98	80	8	ø13.5 on 215 PCD	93	73	50.2	99	108	250

SIZE	Q2	R2	R3	S	S1	S2	S3	T	T2	T3	T4	U3	U4	V	V1	W	W1
A0410	61.5	95.035 95.000	72	101	81	108.6	80	62	126	48	53	3.5	8	24.9 24.8	22.50 22.37	6.015 5.985	6.000 5.970
A0510	61.5	110.035 110.000	88	112	81	118.6	90	75	143	48	53	4	9	28.5 28.3	28.00 27.71	8.018 7.982	8.000 7.964
A0610	69	130.040 130.000	110	132	101	146.3	105	86	171	58	62	4.5	10	38.5 38.3	31.00 30.71	10.018 9.982	8.000 7.964
A0730	69	180.040 180.000	136	153	101	161.3	120	197	192	58	62	5	12	43.5 43.3	33.00 32.71	12.021 11.979	8.000 7.964
A0860	67	180.040 180.000	150	178	112	182.8	132	227	208	63	75	5	12	54.0 53.8	38.00 37.71	14.021 13.979	10.000 9.964

MOTORS		ALL SIZES					A0410		A0510		A0610		A0730		A0860	
		ko	g	g1	g2	g6	k	kb	k	kb	k	kb	k	kb	k	kb
MOTOR FRAME SIZE	63	185	122	101	160	140	314	356	314	356	-	-	-	-	-	-
	71	210	137	107	167	160	340*	381*	340	381	354	395	354	395	385	426
	80	230	158	118	190	200	-	-	-	-	379*	429*	379*	429*	405	455
	90S/L	270	177	149	218	200	-	-	-	-	-	-	-	-	445	504

* When motor shaft vertically up these motors cannot be fitted

SERIES AJ

DIMENSIONS

DOUBLE REDUCTION

A 0 0 0 0 G N

STANDARD UNIT SIDE MOUNTED FEET

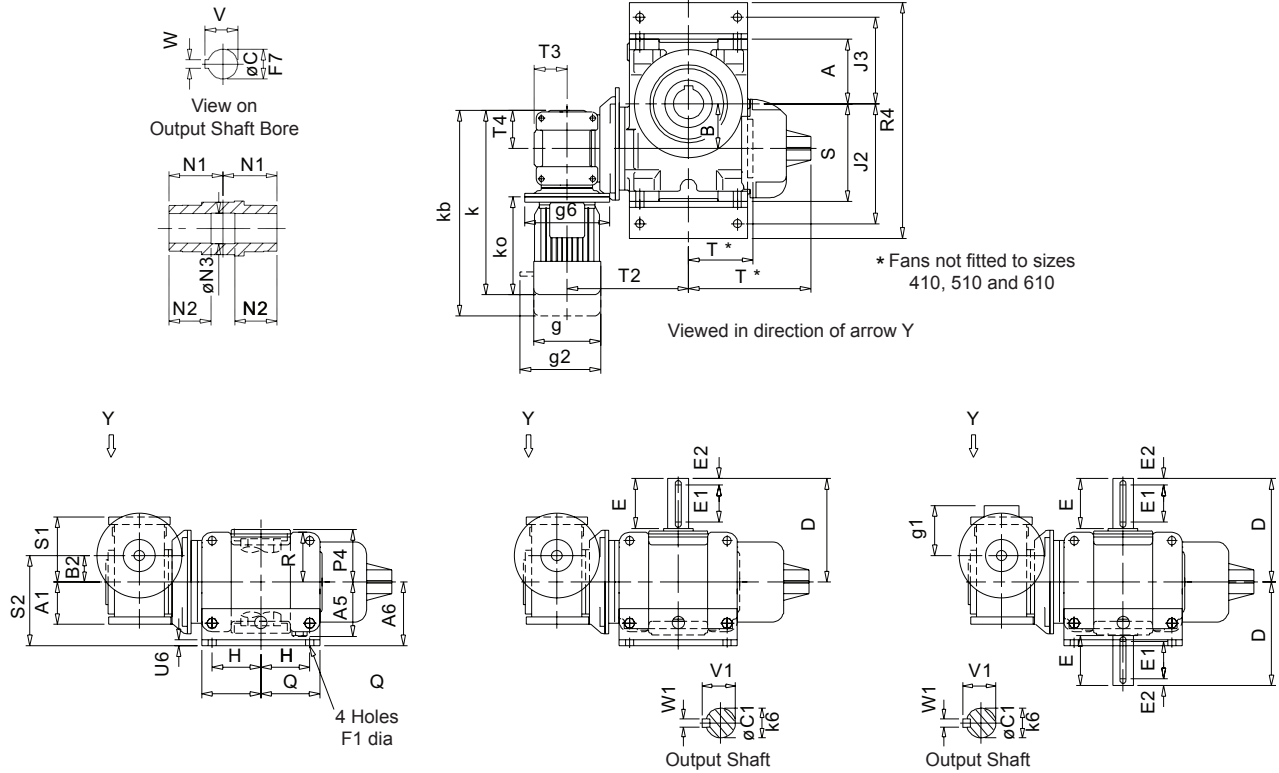

SIZE	A	A1	A5	A6	B	B2	øC	øC1	D	E	E1	E2	F1	H	J2	J3	N1	N2
A0280	66	58	55	75	41.3	28.6	22	20	98	45	34	6	11.5	58.5	127	92	50	40
A0410	74	58	61	78	50.8	28.6	25	25	117	57	42	7	11.5	57	138	100	56	45
A0610	87	66	67	86	60.3	41.3	35	28	140	70	55	7	11.5	66	162	117	64	50
A0730	105	66	81	103	73.0	41.3	40	30	168	83	62	7	13.5	81	186	138	77	60
A0860	117	74	97	118	85.7	50.8	50	35	200	98	80	8	17.5	90	217	156	93	73

SIZE	øN3	P4	Q	R	S	S1	S2	T	T2	T3	T4	U6	V	V1	W	W1
A0280	22.2	55	69	60	101	81	103.6	62	126	48	53	6	24.9 24.8	22.50 22.37	6.015 5.985	6.000 5.970
A0410	25.2	61	67	62	112	81	106.6	75	143	48	53	6	28.5 28.3	28.00 27.71	8.018 7.982	8.000 7.964
A0610	35.2	69	80	67	132	101	127.3	86	171	58	62	8	38.5 38.3	31.00 30.71	10.018 9.982	8.000 7.964
A0730	40.2	84	95	84	153	101	144.3	197	192	58	62	8	43.5 43.3	33.00 32.71	12.021 11.979	8.000 7.964
A0860	50.2	99	108	97	178	112	168.8	227	208	63	75	10	54.0 53.8	38.00 37.71	14.021 13.979	10.000 9.964

MOTORS		ALL SIZES					A0410		A0510		A0610		A0730		A0860	
		ko	g	g1	g2	g6	k	kb	k	kb	k	kb	k	kb	k	kb
MOTOR FRAME SIZE	63	185	122	101	160	140	314*	356*	314	356	-	-	-	-	-	-
	71	210	137	107	167	160	340*	381*	340	381	354	395	354	395	385	426
	80	230	158	118	190	200	-	-	-	-	379*	429*	379	429	405	455
	90S/L	270	177	149	218	200	-	-	-	-	-	-	-	-	445	504

* When motor shaft vertically up these motors cannot be fitted

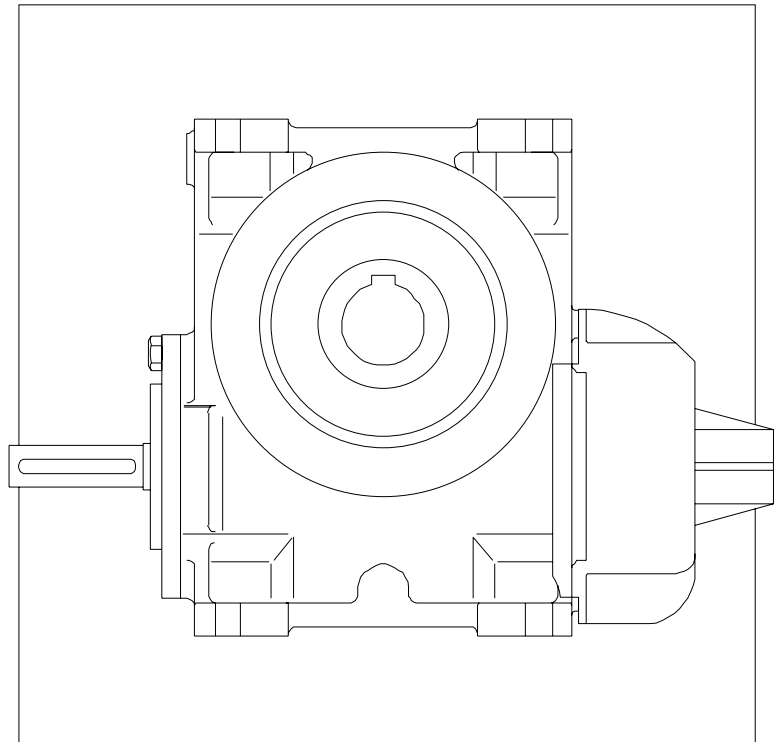

REDUCER
SERIES AJ

OVERHUNG LOADS (NEWTONS) ON OUTPUT SHAFTS

Maximum permissible overhung loads

When a sprocket, gear etc. is mounted on the shaft a calculation, as below, must be made to determine the overhung load on the shaft, and the results compared to the maximum permissible overhung loads tabulated. Overhung loads can be reduced by increasing the diameter to the sprocket, gear, etc. If the maximum permissible overhung load is exceeded, the sprocket, gear, etc. should be mounted on a separate shaft, flexibly coupled and supported in its own bearings, or the gear unit shaft should be extended to run in an outboard bearing. Alternatively, a larger gear is often a less expensive solution.

Permissible overhung loads vary according to the direction of rotation. The values tabulated are for the most unfavourable direction with the unit transmitting full rated power and the load P applied midway along the shaft extension. Hence they can sometimes be increased for a more favourable direction of rotation, or if the power transmitted is less than the rated capacity of the gear unit, or if the load is applied nearer to the gear unit case. Refer to our Application Engineers for further details. In any event, the sprocket, gear etc. should be positioned as close as possible to the gear unit case in order to reduce bearing loads and shaft stresses, and to prolong life.

Overhung loads (Newtons)

$$P = \frac{\text{kW} \times 9,500,000 \times K}{N \times R}$$

where

- P = Equivalent overhung load (Newtons)
- kW = Power transmitted by the shaft (kilowatts)
- N = Speed of shaft (rev/min)
- R = Pitch radius of sproket (mm)
- K = Factor

Overhung member	K (factor)
Chain sprocket*	1.00
Spur or helical pinion	1.25
Vee belt sheave	1.50
Flat belt pulley	2.00

* If multistrand chain drives are equally loaded and the outer strand is further than dimension A output or B or C input refer to our Application Engineers.

Note: 1 Newton = 0.10197 kg = 0.2248 lbs.

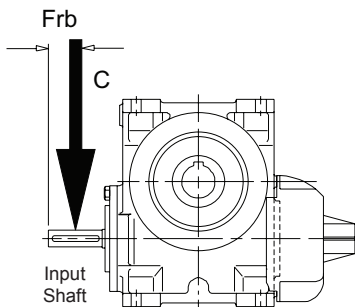

Single reduction
(worm)

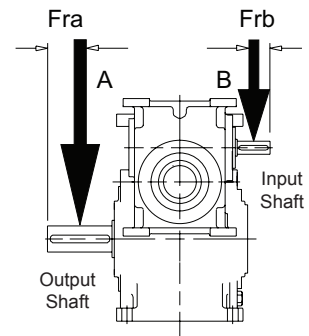
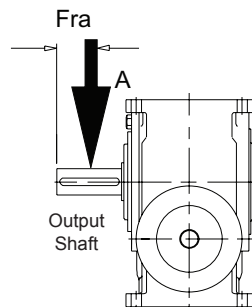

Double reduction
(worm/worm)

Distance midway along the shaft extension

Size of Unit	Dimension A (mm)	Dimension B (mm)	Dimension C (mm)
A0280	17.5	-	14.5
A0410	22.5	14.5	20.5
A0510	28.5	14.5	24
A0610	35	20.5	28.5
A0730	41.5	20.5	35
A0860	49	24	41.5

OVERHUNG LOADS (NEWTONS) & AXIAL THRUSTS (NEWTONS)

OVERHUNG LOADS (Fra) 7 AXIAL THRUST CAPACITIES ON OUTPUT SHAFT

		OUTPUT REV / MIN						
		580	290	190	145	95	70	15 & UNDER
A0280	OHL (Fra)	1410	1400	1390	1390	1380	1380	1330
	THRUST	4780	4920	5010	5020	5080	5080	4320
A0410	OHL (Fra)	2760	2750	2750	2740	2720	2700	2180
	THRUST	6520	6110	6110	6110	6170	6170	4660
A0510	OHL (Fra)	3500	3490	3490	3470	3470	3440	3420
	THRUST	8040	7780	7770	7470	7470	7470	6600
A0610	OHL (Fra)	6130	5800	5800	5530	5530	5520	4570
	THRUST	7480	7160	7160	7060	6750	6700	5760
A0730	OHL (Fra)	6960	6920	6920	6900	6860	6860	6790
	THRUST	12200	11100	11100	11100	11100	10800	10500
A0860	OHL (Fra)	8860	8820	8820	8810	8770	6920	6920
	THRUST	14100	12300	14300	14600	14500	14800	12000

REDUCER OVERHUNG LOADS (Frb) ON INPUT SHAFT

at 1450 rev / min

		RATIO	SIZE				
			A0280	A0410	A0510	A0610	A0730
SINGLE REDUCTION UNIT	5	300	1030	615	705	1840	1400
	7.5	340	860	945	995	1210	1790
	10	305	380	665	905	845	1630
	12.5	650	820	855	650	965	890
	15	400	890	305	725	905	1230
	20	520	335	1040	825	605	796
	25	435	635	1210	1130	1430	2060
	30	560	660	725	1090	803	1330
	40	650	550	405	830	645	1240
	50	670	410	560	760	512	935
	60	680	835	525	665	825	900
70	690	565	485	955	1180	1530	

		RATIO	SIZE			
			A0410	A0510	A0610	A0730
SINGLE REDUCTION UNIT	75	425	310	1100	990	785
	150	485	400	680	650	1050
	200	515	450	700	690	1150
	300	680	660	662	590	1430
	400	695	660	690	655	1530
	600	695	665	710	705	1610
	800	690	650	895	850	845
	1200	690	655	915	905	920
	1600	700	660	925	925	960
	2400	700	660	1020	990	855
	3000	700	665	1030	1020	885
4200	700	665	715	705	785	

SERIES AJ

RATINGS AT 2900 REV/MIN INPUT

	NOMINAL RATIO	NOMINAL OUTPUT SPEED REV / MIN	CAPACITY		SIZE OF UNIT					
					A0280	A0410	A0510	A0610	A0730	A0860
SINGLE REDUCTION	5.0	580.00	Mechanical	Input Power kW	0.98	2.21	4.69	7.03	10.10	17.40
				Output Torque Nm	15.	34.	68.	106.	161.	261.
			Thermal	Input Power kW	2.36	3.17	5.46	7.57	20.00	25.80
				Output Torque Nm	37.	49.	79.	115.	323.	389.
			Efficiency %	88	88	91	92	93	94	
	7.5	386.67	Mechanical	Input Power kW	0.89	1.97	3.36	5.16	7.83	11.90
				Output Torque Nm	18.	41.	72.	112.	172.	262.
			Thermal	Input Power kW	1.87	2.61	4.29	6.19	17.40	21.70
				Output Torque Nm	40.	55.	92.	135.	389.	485.
			Efficiency %	85	86	88	90	92	92	
	10.0	290.00	Mechanical	Input Power kW	0.82	1.97	3.41	4.63	6.58	10.50
				Output Torque Nm	23.	57.	102.	130.	203.	307.
			Thermal	Input Power kW	1.42	2.10	3.28	5.31	14.50	18.20
				Output Torque Nm	41.	61.	97.	150.	455.	535.
			Efficiency %	82	84	86	88	91	92	
	12.5	232.00	Mechanical	Input Power kW	0.74	1.83	3.03	4.74	7.08	9.61
				Output Torque Nm	24.	61.	105.	168.	259.	363.
			Thermal	Input Power kW	1.19	1.79	2.93	4.22	11.50	16.30
				Output Torque Nm	39.	60.	101.	149.	428.	626.
			Efficiency %	78	81	84	86	89	91	
	15.0	193.33	Mechanical	Input Power kW	0.68	1.76	2.73	4.09	6.35	9.59
				Output Torque Nm	25.	67.	109.	171.	267.	408.
			Thermal	Input Power kW	1.18	1.64	2.89	3.78	10.80	13.50
				Output Torque Nm	45.	62.	116.	157.	464.	579.
		Efficiency %	78	79	84	84	88	89		
20.0	145.00	Mechanical	Input Power kW	0.59	1.36	2.58	4.09	4.80	7.18	
			Output Torque Nm	27.	68.	131.	215.	264.	401.	
		Thermal	Input Power kW	0.79	1.55	1.86	2.68	9.18	11.40	
			Output Torque Nm	37.	78.	92.	137.	517.	646.	
		Efficiency %	68	78	75	78	86	87		
25.0	116.00	Mechanical	Input Power kW	0.53	1.33	2.17	3.40	4.81	6.85	
			Output Torque Nm	29.	78.	132.	215.	321.	463.	
		Thermal	Input Power kW	0.73	1.10	1.68	2.39	6.29	7.77	
			Output Torque Nm	41.	63.	100.	148.	426.	529.	
		Efficiency %	66	69	72	75	81	82		
30.0	96.67	Mechanical	Input Power kW	0.44	1.17	1.80	2.75	4.08	6.13	
			Output Torque Nm	27.	79.	128.	201.	320.	490.	
		Thermal	Input Power kW	0.69	1.01	1.60	2.17	5.90	7.32	
			Output Torque Nm	44.	67.	112.	155.	473.	590.	
		Efficiency %	63	67	71	72	79	81		
40.0	72.50	Mechanical	Input Power kW	0.35	0.88	1.38	2.05	2.99	4.51	
			Output Torque Nm	25.	73.	123.	187.	297.	458.	
		Thermal	Input Power kW	0.56	0.90	1.46	1.91	5.08	6.31	
			Output Torque Nm	43.	75.	131.	173.	521.	654.	
		Efficiency %	54	63	68	69	75	77		
50.0	58.00	Mechanical	Input Power kW	0.27	0.71	1.07	1.62	2.36	3.44	
			Output Torque Nm	23.	69.	110.	173.	282.	415.	
		Thermal	Input Power kW	0.44	0.68	1.02	1.38	3.75	4.48	
			Output Torque Nm	39.	65.	105.	145.	463.	552.	
		Efficiency %	51	59	63	64	73	73		
60.0	48.33	Mechanical	Input Power kW	0.20	0.53	0.86	1.34	1.90	2.79	
			Output Torque Nm	17.	55.	100.	163.	256.	385.	
		Thermal	Input Power kW	0.37	0.54	0.89	1.19	3.01	3.71	
			Output Torque Nm	36.	55.	103.	143.	423.	525.	
		Efficiency %	44	52	59	61	68	70		
70.0	41.43	Mechanical	Input Power kW	0.16	0.41	0.64	1.03	1.55	2.42	
			Output Torque Nm	14.	45.	79.	135.	227.	369.	
		Thermal	Input Power kW	0.30	0.46	0.71	0.93	2.30	2.83	
			Output Torque Nm	31.	52.	91.	118.	355.	439.	
		Efficiency %	39	48	54	55	64	66		

RATINGS AT 2900 REV/MIN INPUT

NOMINAL RATIO	NOMINAL OUTPUT SPEED REV / MIN	CAPACITY		SIZE OF UNIT				
				A0410	A0510	A0610	A0730	A0860
75.0	38.67	Mechanical	Input Power kW	0.75	0.90	1.76	1.94	4.13
			Output Torque Nm	123.	156.	314.	360.	742.
		Thermal	Input Power kW	1.00	1.66	2.33	3.06	4.49
			Output Torque Nm	169.	297.	425.	586.	809.
100.	29.00	Mechanical	Input Power kW	0.54	0.90	1.79	1.94	3.08
			Output Torque Nm	114.	191.	391.	471.	713.
		Thermal	Input Power kW	0.94	1.15	1.72	3.06	3.80
			Output Torque Nm	207.	246.	374.	765.	888.
125.	23.20	Mechanical	Input Power kW	0.57	0.90	1.50	1.94	2.99
			Output Torque Nm	137.	228.	386.	557.	822.
		Thermal	Input Power kW	0.69	1.04	1.52	2.29	2.77
			Output Torque Nm	167.	266.	392.	666.	757.
150.	19.33	Mechanical	Input Power kW	0.52	0.74	1.20	1.73	2.65
			Output Torque Nm	149.	229.	384.	597.	943.
		Thermal	Input Power kW	0.82	1.42	1.88	2.03	2.83
			Output Torque Nm	246.	459.	628.	707.	1010.
200.	14.50	Mechanical	Input Power kW	0.35	0.76	1.17	1.33	1.98
			Output Torque Nm	123.	285.	448.	582.	892.
		Thermal	Input Power kW	0.79	0.94	1.37	2.03	2.43
			Output Torque Nm	311.	357.	538.	919.	1120.
225.	12.89	Mechanical	Input Power kW	0.44	0.61	1.02	1.36	2.03
			Output Torque Nm	162.	243.	416.	603.	950.
		Thermal	Input Power kW	0.75	1.29	1.74	1.58	2.44
			Output Torque Nm	296.	548.	758.	709.	1160.
250.	11.60	Mechanical	Input Power kW	0.40	0.65	1.03	1.20	1.81
			Output Torque Nm	163.	282.	463.	603.	950.
		Thermal	Input Power kW	0.57	0.85	1.22	1.66	1.81
			Output Torque Nm	241.	379.	564.	867.	947.
300.	9.67	Mechanical	Input Power kW	0.41	0.54	0.84	1.06	1.66
			Output Torque Nm	174.	257.	445.	603.	950.
		Thermal	Input Power kW	0.77	0.85	1.61	1.50	1.62
			Output Torque Nm	365.	426.	918.	885.	924.
350.	8.29	Mechanical	Input Power kW	0.34	0.54	0.88	0.95	0.83
			Output Torque Nm	175.	304.	498.	603.	437.
		Thermal	Input Power kW	0.53	0.79	1.14	1.55	1.16
			Output Torque Nm	293.	459.	676.	1040.	651.
375.	7.73	Mechanical	Input Power kW	0.15	0.22	0.40	0.53	1.39
			Output Torque Nm	54.	94.	161.	271.	950.
		Thermal	Input Power kW	0.34	0.50	0.74	0.98	1.57
			Output Torque Nm	160.	262.	360.	578.	1080.
400.	7.25	Mechanical	Input Power kW	0.26	0.55	0.80	0.84	1.32
			Output Torque Nm	130.	309.	501.	603.	950.
		Thermal	Input Power kW	0.75	0.85	1.17	1.50	1.62
			Output Torque Nm	464.	505.	772.	1150.	1200.
450.	6.44	Mechanical	Input Power kW	0.30	0.45	0.73	0.83	1.21
			Output Torque Nm	174.	286.	454.	603.	950.
		Thermal	Input Power kW	0.50	0.77	1.06	1.46	1.48
			Output Torque Nm	311.	519.	713.	1140.	1190.
500.	5.80	Mechanical	Input Power kW	0.32	0.48	0.69	0.75	1.17
			Output Torque Nm	187.	309.	501.	603.	950.
		Thermal	Input Power kW	0.55	0.80	1.05	1.46	1.56
			Output Torque Nm	359.	561.	810.	1280.	1330.
600.	4.83	Mechanical	Input Power kW	0.29	0.42	0.60	0.66	1.03
			Output Torque Nm	186.	305.	482.	603.	950.
		Thermal	Input Power kW	0.52	0.79	0.98	1.38	1.48
			Output Torque Nm	381.	640.	856.	1410.	1460.
625.	4.64	Mechanical	Input Power kW	0.28	0.41	0.63	0.68	1.00
			Output Torque Nm	189.	309.	501.	603.	950.
		Thermal	Input Power kW	0.53	0.78	1.07	1.06	1.47
			Output Torque Nm	415.	647.	946.	1030.	1480.
700.	4.14	Mechanical	Input Power kW	0.19	0.18	0.42	0.41	0.65
			Output Torque Nm	109.	105.	328.	358.	617.
		Thermal	Input Power kW	0.30	0.33	0.60	0.44	0.63
			Output Torque Nm	217.	246.	527.	398.	594.
750.	3.87	Mechanical	Input Power kW	0.26	0.36	0.57	0.60	0.89
			Output Torque Nm	189.	309.	501.	603.	950.
		Thermal	Input Power kW	0.50	0.76	1.00	1.06	1.43
			Output Torque Nm	441.	740.	1000.	1200.	1690.
800.	3.63	Mechanical	Input Power kW	0.20	0.35	0.54	0.56	0.80
			Output Torque Nm	136.	282.	501.	603.	950.
		Thermal	Input Power kW	0.56	0.59	1.13	0.88	1.28
			Output Torque Nm	546.	536.	1220.	1050.	1670.
			Efficiency %	27	31	35	42	46

SINGLE REDUCTION

SERIES AJ

RATINGS AT 2900 REV/MIN INPUT

	NOMINAL RATIO	NOMINAL OUTPUT SPEED REV / MIN	CAPACITY		SIZE OF UNIT				
					A0410	A0510	A0610	A0730	A0860
SINGLE REDUCTION	900.	3.22	Mechanical	Input Power kW	0.23	0.32	0.51	0.54	0.77
				Output Torque Nm	189.	309.	501.	603.	950.
			Thermal	Input Power kW	0.49	0.72	0.98	0.98	1.38
				Output Torque Nm	497.	795.	1130.	1260.	1900.
	1000.	2.90	Mechanical	Input Power kW	0.23	0.33	0.47	0.51	0.72
				Output Torque Nm	189.	309.	501.	603.	950.
			Thermal	Input Power kW	0.54	0.59	1.01	0.88	1.28
				Output Torque Nm	567.	634.	1280.	1190.	1900.
	1200.	2.42	Mechanical	Input Power kW	0.21	0.29	0.43	0.45	0.64
				Output Torque Nm	189.	309.	501.	603.	950.
			Thermal	Input Power kW	0.51	0.59	0.95	0.88	1.28
				Output Torque Nm	604.	738.	1360.	1390.	2220.
	1250.	2.32	Mechanical	Input Power kW	0.20	0.28	0.41	0.44	0.64
				Output Torque Nm	189.	309.	501.	603.	950.
			Thermal	Input Power kW	0.44	0.48	0.	8 0.66	0.90
				Output Torque Nm	533.	601.	1310.	1010.	1460.
	1400.	2.07	Mechanical	Input Power kW	0.16	0.18	0.39	0.41	0.57
				Output Torque Nm	141.	162.	501.	603.	950.
			Thermal	Input Power kW	0.30	0.33	0.60	0.44	0.63
				Output Torque Nm	364.	380.	876.	679.	1080.
	1500.	1.93	Mechanical	Input Power kW	0.19	0.25	0.38	0.39	0.57
				Output Torque Nm	189.	309.	501.	603.	950.
			Thermal	Input Power kW	0.44	0.48	0.88	0.66	0.90
				Output Torque Nm	606.	699.	1490.	1180.	1710.
	1600.	1.81	Mechanical	Input Power kW	0.16	0.21	0.33	0.39	0.54
				Output Torque Nm	136.	249.	411.	603.	950.
			Thermal	Input Power kW	0.48	0.59	0.88	0.88	1.20
				Output Torque Nm	685.	929.	1530.	1730.	2570.
1750.	1.66	Mechanical	Input Power kW	0.18	0.18	0.35	0.37	0.52	
			Output Torque Nm	189.	192.	501.	603.	950.	
		Thermal	Input Power kW	0.30	0.33	0.60	0.44	0.63	
			Output Torque Nm	394.	448.	1030.	766.	1220.	
1800.	1.61	Mechanical	Input Power kW	0.18	0.22	0.36	0.38	0.51	
			Output Torque Nm	189.	280.	501.	603.	950.	
		Thermal	Input Power kW	0.37	0.40	0.71	0.52	0.78	
			Output Torque Nm	531.	616.	1250.	959.	1660.	
2000.	1.45	Mechanical	Input Power kW	0.14	0.19	0.29	0.34	0.49	
			Output Torque Nm	137.	252.	416.	603.	950.	
		Thermal	Input Power kW	0.44	0.48	0.86	0.66	0.90	
			Output Torque Nm	746.	880.	1780.	1470.	2130.	
2100.	1.38	Mechanical	Input Power kW	0.17	0.18	0.32	0.34	0.47	
			Output Torque Nm	189.	223.	501.	603.	950.	
		Thermal	Input Power kW	0.30	0.33	0.60	0.44	0.63	
			Output Torque Nm	447.	521.	1170.	893.	1430.	
2400.	1.21	Mechanical	Input Power kW	0.14	0.18	0.29	0.33	0.44	
			Output Torque Nm	138.	254.	419.	603.	950.	
		Thermal	Input Power kW	0.37	0.40	0.71	0.52	0.78	
			Output Torque Nm	654.	775.	1540.	1190.	2060.	
2500.	1.16	Mechanical	Input Power kW	0.11	0.14	0.23	0.28	0.40	
			Output Torque Nm	99.	180.	299.	522.	817.	
		Thermal	Input Power kW	0.43	0.48	0.76	0.66	0.90	
			Output Torque Nm	859.	999.	1800.	1750.	2490.	
2800.	1.04	Mechanical	Input Power kW	0.13	0.17	0.26	0.30	0.40	
			Output Torque Nm	139.	256.	422.	603.	950.	
		Thermal	Input Power kW	0.30	0.33	0.60	0.44	0.63	
			Output Torque Nm	550.	656.	1440.	1110.	1780.	
3000.	0.97	Mechanical	Input Power kW	0.11	0.14	0.23	0.28	0.36	
			Output Torque Nm	99.	182.	302.	526.	824.	
		Thermal	Input Power kW	0.37	0.40	0.71	0.52	0.78	
			Output Torque Nm	776.	880.	1780.	1420.	2410.	
3500.	0.83	Mechanical	Input Power kW	0.11	0.14	0.21	0.25	0.34	
			Output Torque Nm	100.	184.	305.	532.	833.	
		Thermal	Input Power kW	0.30	0.33	0.60	0.44	0.63	
			Output Torque Nm	653.	744.	1680.	1320.	2070.	
3600.	0.81	Mechanical	Input Power kW	0.10	0.12	0.20	0.23	0.29	
			Output Torque Nm	76.	140.	231.	400.	624.	
		Thermal	Input Power kW	0.37	0.40	0.71	0.52	0.78	
			Output Torque Nm	820.	1000.	2040.	1570.	2720.	
4200.	0.69	Mechanical	Input Power kW	0.10	0.12	0.18	0.21	0.27	
			Output Torque Nm	77.	141.	233.	404.	631.	
		Thermal	Input Power kW	0.30	0.33	0.60	0.44	0.63	
			Output Torque Nm	689.	850.	1910.	1460.	2340.	
			Efficiency %	6	9	10	14	17	

SERIES AJ

RATINGS AT 1750 REV/MIN INPUT

	NOMINAL RATIO	NOMINAL OUTPUT SPEED REV / MIN	CAPACITY		SIZE OF UNIT					
					A0280	A0410	A0510	A0610	A0730	A0860
SINGLE REDUCTION	5.0	350.00	Mechanical	Input Power kW	0.74	1.68	3.61	5.41	7.73	13.40
				Output Torque Nm	19.	43.	86.	135.	205.	332.
			Thermal	Input Power kW	1.82	2.65	4.38	6.14	14.10	17.70
				Output Torque Nm	46.	68.	104.	153.	376.	441.
			Efficiency %	88	88	91	91	93	94	
	7.5	233.33	Mechanical	Input Power kW	0.68	1.49	2.55	3.93	5.94	9.02
				Output Torque Nm	23.	51.	90.	141.	217.	331.
			Thermal	Input Power kW	1.46	2.20	3.54	5.15	12.20	15.00
				Output Torque Nm	51.	77.	126.	185.	450.	552.
			Efficiency %	85	86	88	90	92	93	
	10.0	175.00	Mechanical	Input Power kW	0.62	1.48	2.5	8 3.50	4.94	7.95
				Output Torque Nm	29.	71.	126.	162.	252.	384.
			Thermal	Input Power kW	1.12	1.77	2.73	4.43	10.10	12.50
				Output Torque Nm	53.	85.	134.	206.	522.	608.
			Efficiency %	81	83	85	88	90	92	
	12.5	140.00	Mechanical	Input Power kW	0.56	1.36	2.27	3.57	5.29	7.18
				Output Torque Nm	29.	76.	130.	208.	321.	449.
			Thermal	Input Power kW	0.94	1.52	2.43	3.55	8.13	11.20
				Output Torque Nm	51.	85.	139.	207.	497.	703.
			Efficiency %	77	81	84	85	89	90	
	15.0	116.67	Mechanical	Input Power kW	0.50	1.31	2.03	3.07	4.72	7.15
				Output Torque Nm	31.	83.	134.	210.	329.	503.
			Thermal	Input Power kW	0.93	1.39	2.37	3.17	7.62	9.30
				Output Torque Nm	58.	87.	157.	217.	536.	657.
			Efficiency %	77	80	83	84	88	89	
	20.0	87.50	Mechanical	Input Power kW	0.44	1.00	1.93	3.07	3.53	5.31
				Output Torque Nm	32.	83.	160.	262.	322.	489.
			Thermal	Input Power kW	0.64	1.29	1.57	2.29	6.42	7.80
Output Torque Nm				48.	108.	129.	194.	593.	725.	
		Efficiency %	67	78	75	78	86	87		
25.0	70.00	Mechanical	Input Power kW	0.40	0.98	1.62	2.54	3.55	5.07	
			Output Torque Nm	35.	94.	160.	261.	390.	564.	
		Thermal	Input Power kW	0.59	0.93	1.41	2.04	4.50	5.46	
			Output Torque Nm	53.	89.	139.	208.	499.	609.	
		Efficiency %	65	70	72	75	81	82		
30.0	58.33	Mechanical	Input Power kW	0.33	0.87	1.34	2.06	3.00	4.53	
			Output Torque Nm	33.	95.	154.	243.	388.	595.	
		Thermal	Input Power kW	0.55	0.85	1.33	1.84	4.18	5.10	
			Output Torque Nm	57.	93.	153.	217.	547.	672.	
		Efficiency %	61	67	70	72	79	80		
40.0	43.75	Mechanical	Input Power kW	0.26	0.65	1.02	1.52	2.19	3.32	
			Output Torque Nm	30.	88.	148.	225.	359.	555.	
		Thermal	Input Power kW	0.45	0.76	1.21	1.62	3.59	4.38	
			Output Torque Nm	55.	104.	177.	239.	598.	739.	
		Efficiency %	53	62	66	68	75	77		
50.0	35.00	Mechanical	Input Power kW	0.18	0.48	0.79	1.20	1.72	2.52	
			Output Torque Nm	24.	75.	132.	207.	339.	501.	
		Thermal	Input Power kW	0.35	0.57	0.86	1.19	2.67	3.13	
			Output Torque Nm	51.	93.	146.	206.	536.	627.	
		Efficiency %	49	58	61	63	72	73		
60.0	29.17	Mechanical	Input Power kW	0.13	0.35	0.57	0.90	1.38	2.09	
			Output Torque Nm	19.	58.	107.	177.	307.	476.	
		Thermal	Input Power kW	0.30	0.46	0.75	1.03	2.16	2.60	
			Output Torque Nm	47.	81.	144.	204.	493.	599.	
		Efficiency %	43	51	58	60	68	70		
70.0	25.00	Mechanical	Input Power kW	0.10	0.26	0.41	0.68	1.00	1.58	
			Output Torque Nm	15.	48.	84.	144.	242.	393.	
		Thermal	Input Power kW	0.24	0.39	0.61	0.80	1.67	2.00	
			Output Torque Nm	42.	78.	130.	173.	419.	509.	
		Efficiency %	39	48	54	55	63	65		

SERIES AJ

RATINGS AT 1750 REV/MIN INPUT

	NOMINAL RATIO	NOMINAL OUTPUT SPEED REV / MIN	CAPACITY		SIZE OF UNIT				
					A0410	A0510	A0610	A0730	A0860
SINGLE REDUCTION	75.0	23.33	Mechanical	Input Power kW	0.53	0.69	1.25	1.47	3.00
				Output Torque Nm	142.	193.	365.	447.	872.
			Thermal	Input Power kW	0.81	1.41	1.91	2.57	3.16
				Output Torque Nm	221.	405.	566.	799.	920.
	100.	17.50	Mechanical	Input Power kW	0.35	0.69	1.23	1.40	2.21
				Output Torque Nm	121.	233.	434.	555.	829.
			Thermal	Input Power kW	0.78	0.94	1.37	2.32	2.69
				Output Torque Nm	279.	323.	482.	936.	1010.
	125.	14.00	Mechanical	Input Power kW	0.41	0.67	1.07	1.31	2.15
				Output Torque Nm	156.	270.	443.	603.	950.
			Thermal	Input Power kW	0.55	0.84	1.22	1.70	1.96
				Output Torque Nm	217.	343.	509.	794.	862.
	150.	11.67	Mechanical	Input Power kW	0.36	0.50	0.83	1.09	1.66
				Output Torque Nm	169.	251.	434.	603.	950.
			Thermal	Input Power kW	0.68	1.16	1.57	1.71	2.24
				Output Torque Nm	333.	601.	854.	975.	1300.
	200.	8.75	Mechanical	Input Power kW	0.22	0.52	0.79	0.85	1.30
				Output Torque Nm	128.	309.	493.	603.	950.
			Thermal	Input Power kW	0.66	0.79	1.13	1.71	1.93
				Output Torque Nm	423.	483.	721.	1260.	1440.
	225.	7.78	Mechanical	Input Power kW	0.30	0.41	0.69	0.85	1.26
				Output Torque Nm	181.	264.	465.	603.	950.
			Thermal	Input Power kW	0.65	0.94	1.48	1.34	2.07
				Output Torque Nm	412.	637.	1050.	986.	1590.
	250.	7.00	Mechanical	Input Power kW	0.28	0.44	0.69	0.75	1.13
				Output Torque Nm	182.	309.	501.	603.	950.
			Thermal	Input Power kW	0.47	0.71	1.00	1.40	1.43
				Output Torque Nm	329.	515.	755.	1180.	1210.
300.	5.83	Mechanical	Input Power kW	0.27	0.37	0.57	0.66	1.04	
			Output Torque Nm	189.	278.	494.	603.	950.	
		Thermal	Input Power kW	0.60	0.63	1.38	1.26	1.39	
			Output Torque Nm	454.	498.	1270.	1200.	1300.	
350.	5.00	Mechanical	Input Power kW	0.23	0.35	0.55	0.59	0.53	
			Output Torque Nm	189.	309.	501.	603.	453.	
		Thermal	Input Power kW	0.45	0.68	0.95	1.34	0.82	
			Output Torque Nm	404.	630.	923.	1470.	752.	
375.	4.67	Mechanical	Input Power kW	0.09	0.14	0.25	0.33	0.87	
			Output Torque Nm	56.	98.	167.	281.	950.	
		Thermal	Input Power kW	0.28	0.43	0.62	0.73	1.32	
			Output Torque Nm	222.	363.	507.	698.	1490.	
400.	4.38	Mechanical	Input Power kW	0.17	0.35	0.50	0.52	0.83	
			Output Torque Nm	135.	309.	501.	603.	950.	
		Thermal	Input Power kW	0.60	0.63	0.99	1.26	1.39	
			Output Torque Nm	597.	585.	1060.	1560.	1680.	
450.	3.89	Mechanical	Input Power kW	0.20	0.30	0.49	0.52	0.75	
			Output Torque Nm	189.	309.	501.	603.	950.	
		Thermal	Input Power kW	0.42	0.66	0.89	1.28	1.25	
			Output Torque Nm	429.	721.	976.	1630.	1650.	
500.	3.50	Mechanical	Input Power kW	0.20	0.30	0.43	0.46	0.73	
			Output Torque Nm	189.	309.	501.	603.	950.	
		Thermal	Input Power kW	0.47	0.63	0.88	1.25	1.33	
			Output Torque Nm	499.	692.	1110.	1780.	1840.	
600.	2.92	Mechanical	Input Power kW	0.18	0.27	0.3	8 0.41	0.64	
			Output Torque Nm	189.	309.	501.	603.	950.	
		Thermal	Input Power kW	0.44	0.63	0.83	1.22	1.26	
			Output Torque Nm	531.	805.	1180.	2010.	2030.	
625.	2.80	Mechanical	Input Power kW	0.17	0.26	0.39	0.42	0.63	
			Output Torque Nm	189.	309.	501.	603.	950.	
		Thermal	Input Power kW	0.46	0.57	0.91	0.90	1.25	
			Output Torque Nm	581.	750.	1310.	1430.	2050.	
700.	2.50	Mechanical	Input Power kW	0.12	0.12	0.27	0.26	0.42	
			Output Torque Nm	115.	111.	346.	377.	650.	
		Thermal	Input Power kW	0.24	0.27	0.50	0.38	0.54	
			Output Torque Nm	296.	329.	748.	606.	875.	
750.	2.33	Mechanical	Input Power kW	0.16	0.23	0.35	0.37	0.55	
			Output Torque Nm	189.	309.	501.	603.	950.	
		Thermal	Input Power kW	0.43	0.57	0.86	0.90	1.25	
			Output Torque Nm	619.	872.	1390.	1670.	2390.	
800.	2.19	Mechanical	Input Power kW	0.12	0.24	0.33	0.35	0.49	
			Output Torque Nm	140.	309.	501.	603.	950.	
		Thermal	Input Power kW	0.42	0.44	0.88	0.74	1.07	
			Output Torque Nm	646.	627.	1520.	1450.	2260.	
800.	2.19		Efficiency %	27	30	35	41	45	

RATINGS AT 1750 REV/MIN INPUT

NOMINAL RATIO	NOMINAL OUTPUT SPEED REV / MIN	CAPACITY		SIZE OF UNIT				
				A0410	A0510	A0610	A0730	A0860
900.	1.94	Mechanical	Input Power kW	0.14	0.20	0.32	0.33	0.48
			Output Torque Nm	189.	309.	501.	603.	950.
		Thermal	Input Power kW	0.43	0.53	0.85	0.83	1.18
			Output Torque Nm	704.	924.	1570.	1730.	2630.
			Efficiency %	27	31	32	37	40
1000.	1.75	Mechanical	Input Power kW	0.14	0.21	0.29	0.31	0.44
			Output Torque Nm	189.	309.	501.	603.	950.
		Thermal	Input Power kW	0.42	0.44	0.88	0.74	1.07
			Output Torque Nm	699.	741.	1790.	1640.	2560.
			Efficiency %	24	27	32	35	39
1200.	1.46	Mechanical	Input Power kW	0.13	0.18	0.26	0.28	0.39
			Output Torque Nm	189.	309.	501.	603.	950.
		Thermal	Input Power kW	0.42	0.44	0.83	0.74	1.07
			Output Torque Nm	794.	862.	1920.	1910.	2990.
			Efficiency %	22	26	29	33	37
1250.	1.40	Mechanical	Input Power kW	0.12	0.18	0.25	0.27	0.40
			Output Torque Nm	189.	309.	501.	603.	950.
		Thermal	Input Power kW	0.35	0.38	0.74	0.56	0.77
			Output Torque Nm	690.	748.	1770.	1430.	2050.
			Efficiency %	22	26	29	33	35
1400.	1.25	Mechanical	Input Power kW	0.10	0.12	0.24	0.25	0.35
			Output Torque Nm	144.	170.	501.	603.	950.
		Thermal	Input Power kW	0.24	0.27	0.50	0.38	0.54
			Output Torque Nm	495.	505.	1230.	1030.	1590.
			Efficiency %	20	19	27	33	36
1500.	1.17	Mechanical	Input Power kW	0.11	0.16	0.23	0.24	0.35
			Output Torque Nm	189.	309.	501.	603.	950.
		Thermal	Input Power kW	0.35	0.38	0.74	0.56	0.77
			Output Torque Nm	783.	869.	2010.	1670.	2400.
			Efficiency %	20	24	27	31	33
1600.	1.09	Mechanical	Input Power kW	0.09	0.13	0.20	0.24	0.33
			Output Torque Nm	139.	255.	421.	603.	950.
		Thermal	Input Power kW	0.42	0.44	0.77	0.74	1.07
			Output Torque Nm	978.	1080.	2170.	2370.	3720.
			Efficiency %	17	22	24	29	33
1750.	1.00	Mechanical	Input Power kW	0.11	0.12	0.21	0.23	0.32
			Output Torque Nm	189.	201.	501.	603.	950.
		Thermal	Input Power kW	0.24	0.27	0.50	0.38	0.54
			Output Torque Nm	532.	596.	1450.	1150.	1780.
			Efficiency %	18	18	25	28	31
1800.	0.97	Mechanical	Input Power kW	0.11	0.14	0.22	0.23	0.31
			Output Torque Nm	189.	293.	501.	603.	950.
		Thermal	Input Power kW	0.30	0.32	0.60	0.45	0.66
			Output Torque Nm	699.	799.	1720.	1410.	2350.
			Efficiency %	17	21	23	27	31
2000.	0.88	Mechanical	Input Power kW	0.08	0.12	0.1	0.21	0.30
			Output Torque Nm	141.	259.	426.	603.	950.
		Thermal	Input Power kW	0.35	0.38	0.74	0.56	0.77
			Output Torque Nm	963.	1090.	2470.	2070.	2980.
			Efficiency %	15	20	22	27	29
2100.	0.83	Mechanical	Input Power kW	0.10	0.12	0.20	0.21	0.28
			Output Torque Nm	189.	233.	501.	603.	950.
		Thermal	Input Power kW	0.24	0.27	0.50	0.38	0.54
			Output Torque Nm	604.	692.	1650.	1340.	2080.
			Efficiency %	16	18	22	26	29
2400.	0.73	Mechanical	Input Power kW	0.08	0.11	0.17	0.20	0.27
			Output Torque Nm	143.	262.	432.	603.	950.
		Thermal	Input Power kW	0.30	0.32	0.60	0.45	0.66
			Output Torque Nm	860.	1010.	2110.	1750.	2910.
			Efficiency %	13	18	19	23	27
2500.	0.70	Mechanical	Input Power kW	0.07	0.09	0.13	0.17	0.24
			Output Torque Nm	102.	186.	308.	538.	843.
		Thermal	Input Power kW	0.35	0.38	0.67	0.56	0.77
			Output Torque Nm	1140.	1240.	2580.	2460.	3480.
			Efficiency %	11	15	17	23	25
2800.	0.63	Mechanical	Input Power kW	0.08	0.11	0.16	0.18	0.24
			Output Torque Nm	144.	265.	436.	603.	950.
		Thermal	Input Power kW	0.24	0.27	0.50	0.38	0.54
			Output Torque Nm	743.	871.	2020.	1660.	2580.
			Efficiency %	12	16	18	22	26
3000.	0.58	Mechanical	Input Power kW	0.07	0.09	0.13	0.17	0.22
			Output Torque Nm	103.	188.	312.	545.	853.
		Thermal	Input Power kW	0.30	0.32	0.60	0.45	0.66
			Output Torque Nm	1020.	1140.	2450.	2080.	3400.
			Efficiency %	10	13	14	20	24
3500.	0.50	Mechanical	Input Power kW	0.06	0.08	0.12	0.15	0.20
			Output Torque Nm	104.	190.	315.	550.	862.
		Thermal	Input Power kW	0.24	0.27	0.50	0.38	0.54
			Output Torque Nm	880.	986.	2340.	1980.	3000.
			Efficiency %	9	12	14	19	22
3600.	0.49	Mechanical	Input Power kW	0.06	0.07	0.11	0.14	0.17
			Output Torque Nm	79.	144.	239.	414.	645.
		Thermal	Input Power kW	0.30	0.32	0.60	0.45	0.66
			Output Torque Nm	1070.	1300.	2800.	2300.	3830.
			Efficiency %	7	10	11	16	19
4200.	0.42	Mechanical	Input Power kW	0.06	0.07	0.10	0.12	0.16
			Output Torque Nm	79.	146.	241.	418.	652.
		Thermal	Input Power kW	0.24	0.27	0.50	0.38	0.54
			Output Torque Nm	927.	1130.	2680.	2180.	3380.
			Efficiency %	6	9	11	15	18

SINGLE REDUCTION

SERIES AJ

RATINGS AT 1450 REV/MIN INPUT

	NOMINAL RATIO	NOMINAL OUTPUT SPEED REV / MIN	CAPACITY		SIZE OF UNIT					
					A0280	A0410	A0510	A0610	A0730	A0860
SINGLE REDUCTION	5.0	290.00	Mechanical	Input Power kW	0.67	1.52	3.26	4.90	6.98	12.10
				Output Torque Nm	20.	46.	93.	147.	223.	362.
			Thermal	Input Power kW	1.65	2.45	4.01	5.65	12.30	15.30
				Output Torque Nm	51.	75.	115.	170.	394.	457.
			Efficiency %	87	88	91	91	93	94	
	7.5	193.33	Mechanical	Input Power kW	0.61	1.34	2.30	3.54	5.34	8.12
				Output Torque Nm	25.	56.	98.	152.	235.	359.
			Thermal	Input Power kW	1.33	2.04	3.26	4.77	10.60	12.90
				Output Torque Nm	55.	86.	140.	206.	471.	574.
			Efficiency %	85	86	88	89	92	93	
	10.0	145.00	Mechanical	Input Power kW	0.55	1.32	2.31	3.14	4.42	7.14
				Output Torque Nm	31.	76.	136.	175.	272.	414.
			Thermal	Input Power kW	1.02	1.64	2.53	4.12	8.78	10.80
				Output Torque Nm	58.	95.	149.	230.	545.	632.
			Efficiency %	80	83	85	88	90	91	
	12.5	116.00	Mechanical	Input Power kW	0.50	1.22	2.04	3.20	4.74	6.43
				Output Torque Nm	31.	81.	139.	224.	345.	484.
			Thermal	Input Power kW	0.86	1.41	2.25	3.30	7.10	9.63
				Output Torque Nm	56.	95.	155.	231.	521.	729.
			Efficiency %	77	81	83	85	88	90	
15.0	96.67	Mechanical	Input Power kW	0.45	1.17	1.82	2.75	4.22	6.40	
			Output Torque Nm	33.	89.	143.	225.	354.	541.	
		Thermal	Input Power kW	0.85	1.29	2.20	2.95	6.64	8.05	
			Output Torque Nm	63.	98.	174.	242.	561.	683.	
		Efficiency %	77	79	82	83	88	89		
20.0	72.50	Mechanical	Input Power kW	0.39	0.89	1.74	2.76	3.15	4.74	
			Output Torque Nm	35.	88.	171.	281.	345.	525.	
		Thermal	Input Power kW	0.58	1.20	1.47	2.15	5.59	6.74	
			Output Torque Nm	52.	120.	144.	217.	620.	751.	
		Efficiency %	67	77	74	77	85	86		
25.0	58.00	Mechanical	Input Power kW	0.35	0.88	1.45	2.28	3.17	4.54	
			Output Torque Nm	37.	100.	172.	280.	418.	605.	
		Thermal	Input Power kW	0.54	0.87	1.32	1.91	3.95	4.75	
			Output Torque Nm	58.	99.	155.	233.	524.	635.	
		Efficiency %	64	69	71	74	80	81		
30.0	48.33	Mechanical	Input Power kW	0.29	0.77	1.20	1.85	2.68	4.06	
			Output Torque Nm	35.	102.	165.	260.	415.	638.	
		Thermal	Input Power kW	0.50	0.80	1.24	1.73	3.67	4.43	
			Output Torque Nm	62.	104.	171.	242.	573.	699.	
		Efficiency %	61	67	70	71	78	80		
40.0	36.25	Mechanical	Input Power kW	0.23	0.58	0.91	1.37	1.96	2.97	
			Output Torque Nm	31.	94.	158.	241.	384.	594.	
		Thermal	Input Power kW	0.41	0.71	1.12	1.51	3.14	3.81	
			Output Torque Nm	59.	117.	197.	268.	626.	767.	
		Efficiency %	53	62	66	67	74	76		
50.0	29.00	Mechanical	Input Power kW	0.16	0.41	0.70	1.07	1.54	2.25	
			Output Torque Nm	25.	77.	141.	221.	362.	535.	
		Thermal	Input Power kW	0.33	0.54	0.81	1.12	2.35	2.73	
			Output Torque Nm	56.	105.	163.	231.	563.	653.	
		Efficiency %	49	58	61	63	71	72		
60.0	24.17	Mechanical	Input Power kW	0.11	0.30	0.49	0.77	1.18	1.80	
			Output Torque Nm	19.	60.	110.	181.	314.	490.	
		Thermal	Input Power kW	0.27	0.44	0.70	0.97	1.91	2.27	
			Output Torque Nm	51.	91.	162.	230.	519.	624.	
		Efficiency %	43	51	57	59	67	69		
70.0	20.71	Mechanical	Input Power kW	0.09	0.22	0.35	0.58	0.86	1.35	
			Output Torque Nm	15.	49.	86.	147.	247.	402.	
		Thermal	Input Power kW	0.23	0.37	0.57	0.76	1.48	1.76	
			Output Torque Nm	46.	88.	146.	196.	442.	533.	
		Efficiency %	38	48	53	55	62	65		

RATINGS AT 1450 REV/MIN INPUT

	NOMINAL RATIO	NOMINAL OUTPUT SPEED REV / MIN	CAPACITY		SIZE OF UNIT				
					A0410	A0510	A0610	A0730	A0860
SINGLE REDUCTION	75.0	19.33	Mechanical	Input Power kW	0.47	0.62	1.10	1.32	2.65
				Output Torque Nm	149.	208.	384.	483.	920.
			Thermal	Input Power kW	0.75	1.33	1.77	2.38	2.81
				Output Torque Nm	246.	459.	628.	884.	976.
	100.	14.50	Mechanical	Input Power kW	0.30	0.62	1.07	1.23	1.95
				Output Torque Nm	123.	250.	448.	582.	872.
			Thermal	Input Power kW	0.73	0.87	1.28	2.12	2.39
				Output Torque Nm	311.	357.	538.	1020.	1080.
	125.	11.60	Mechanical	Input Power kW	0.36	0.59	0.94	1.10	1.81
				Output Torque Nm	163.	282.	463.	603.	950.
			Thermal	Input Power kW	0.51	0.78	1.13	1.56	1.75
				Output Torque Nm	241.	379.	564.	867.	913.
	150.	9.67	Mechanical	Input Power kW	0.32	0.43	0.72	0.91	1.39
				Output Torque Nm	176.	259.	452.	603.	950.
			Thermal	Input Power kW	0.65	1.03	1.48	1.59	2.11
				Output Torque Nm	377.	640.	962.	1080.	1460.
	200.	7.25	Mechanical	Input Power kW	0.19	0.44	0.68	0.71	1.09
				Output Torque Nm	130.	309.	501.	603.	950.
			Thermal	Input Power kW	0.63	0.75	1.06	1.59	1.82
				Output Torque Nm	479.	544.	809.	1400.	1620.
	225.	6.44	Mechanical	Input Power kW	0.26	0.35	0.60	0.71	1.06
				Output Torque Nm	187.	272.	483.	603.	950.
			Thermal	Input Power kW	0.61	0.84	1.40	1.25	1.95
				Output Torque Nm	466.	679.	1180.	1100.	1800.
	250.	5.80	Mechanical	Input Power kW	0.24	0.37	0.58	0.63	0.95
				Output Torque Nm	189.	309.	501.	603.	950.
			Thermal	Input Power kW	0.45	0.68	0.94	1.34	1.34
				Output Torque Nm	371.	579.	848.	1350.	1370.
300.	4.83	Mechanical	Input Power kW	0.23	0.32	0.48	0.55	0.8	
			Output Torque Nm	189.	286.	501.	603.	950.	
		Thermal	Input Power kW	0.54	0.56	1.31	1.17	1.30	
			Output Torque Nm	483.	531.	1440.	1340.	1450.	
350.	4.14	Mechanical	Input Power kW	0.19	0.29	0.46	0.50	0.45	
			Output Torque Nm	189.	309.	501.	603.	459.	
		Thermal	Input Power kW	0.43	0.64	0.90	1.25	0.74	
			Output Torque Nm	457.	712.	1040.	1630.	802.	
375.	3.87	Mechanical	Input Power kW	0.08	0.12	0.21	0.28	0.73	
			Output Torque Nm	56.	99.	169.	284.	950.	
		Thermal	Input Power kW	0.27	0.41	0.59	0.67	1.25	
			Output Torque Nm	252.	413.	579.	766.	1680.	
400.	3.63	Mechanical	Input Power kW	0.14	0.30	0.42	0.44	0.69	
			Output Torque Nm	136.	309.	501.	603.	950.	
		Thermal	Input Power kW	0.54	0.56	0.94	1.17	1.30	
			Output Torque Nm	636.	621.	1200.	1730.	1880.	
450.	3.22	Mechanical	Input Power kW	0.17	0.25	0.41	0.43	0.63	
			Output Torque Nm	189.	309.	501.	603.	950.	
		Thermal	Input Power kW	0.40	0.63	0.84	1.23	1.19	
			Output Torque Nm	486.	816.	1100.	1870.	1860.	
500.	2.90	Mechanical	Input Power kW	0.17	0.26	0.36	0.39	0.62	
			Output Torque Nm	189.	309.	501.	603.	950.	
		Thermal	Input Power kW	0.45	0.56	0.84	1.17	1.28	
			Output Torque Nm	567.	735.	1260.	1970.	2100.	
600.	2.42	Mechanical	Input Power kW	0.15	0.22	0.32	0.34	0.54	
			Output Torque Nm	189.	309.	501.	603.	950.	
		Thermal	Input Power kW	0.42	0.56	0.78	1.15	1.21	
			Output Torque Nm	604.	854.	1340.	2270.	2320.	
625.	2.32	Mechanical	Input Power kW	0.15	0.22	0.33	0.36	0.53	
			Output Torque Nm	189.	309.	501.	603.	950.	
		Thermal	Input Power kW	0.44	0.52	0.87	0.84	1.17	
			Output Torque Nm	664.	797.	1490.	1590.	2280.	
700.	2.07	Mechanical	Input Power kW	0.10	0.10	0.23	0.22	0.36	
			Output Torque Nm	117.	113.	352.	384.	661.	
		Thermal	Input Power kW	0.23	0.25	0.47	0.36	0.51	
			Output Torque Nm	329.	365.	840.	691.	991.	
750.	1.93	Mechanical	Input Power kW	0.13	0.19	0.30	0.31	0.46	
			Output Torque Nm	189.	309.	501.	603.	950.	
		Thermal	Input Power kW	0.41	0.52	0.82	0.84	1.17	
			Output Torque Nm	707.	927.	1580.	1850.	2670.	
800.	1.81	Mechanical	Input Power kW	0.10	0.20	0.28	0.29	0.41	
			Output Torque Nm	142.	309.	501.	603.	950.	
		Thermal	Input Power kW	0.38	0.40	0.79	0.69	1.00	
			Output Torque Nm	690.	668.	1630.	1610.	2510.	
			Efficiency %	27	29	34	41	45	

SERIES AJ

RATINGS AT 1450 REV/MIN INPUT

	NOMINAL RATIO	NOMINAL OUTPUT SPEED REV / MIN	CAPACITY		SIZE OF UNIT				
					A0410	A0510	A0610	A0730	A0860
SINGLE REDUCTION	900.	1.61	Mechanical	Input Power kW	0.12	0.17	0.26	0.28	0.40
				Output Torque Nm	189.	309.	501.	603.	950.
			Thermal	Input Power kW	0.41	0.48	0.81	0.77	1.10
				Output Torque Nm	805.	984.	1790.	1930.	2910.
	1000.	1.45	Mechanical	Input Power kW	0.12	0.17	0.24	0.26	0.37
				Output Torque Nm	189.	309.	501.	603.	950.
			Thermal	Input Power kW	0.38	0.40	0.79	0.69	1.00
				Output Torque Nm	746.	788.	1930.	1820.	2840.
	1200.	1.21	Mechanical	Input Power kW	0.11	0.16	0.22	0.23	0.33
				Output Torque Nm	189.	309.	501.	603.	950.
			Thermal	Input Power kW	0.38	0.40	0.79	0.69	1.00
				Output Torque Nm	847.	916.	2190.	2120.	3310.
	1250.	1.16	Mechanical	Input Power kW	0.10	0.15	0.21	0.23	0.33
				Output Torque Nm	189.	309.	501.	603.	950.
			Thermal	Input Power kW	0.33	0.34	0.68	0.52	0.72
				Output Torque Nm	755.	799.	1930.	1600.	2300.
	1400.	1.04	Mechanical	Input Power kW	0.08	0.10	0.20	0.21	0.30
				Output Torque Nm	145.	173.	501.	603.	950.
			Thermal	Input Power kW	0.23	0.25	0.47	0.36	0.51
				Output Torque Nm	550.	558.	1380.	1170.	1790.
	1500.	0.97	Mechanical	Input Power kW	0.10	0.13	0.19	0.20	0.29
				Output Torque Nm	189.	309.	501.	603.	950.
			Thermal	Input Power kW	0.33	0.34	0.68	0.52	0.72
				Output Torque Nm	857.	929.	2190.	1870.	2680.
	1600.	0.91	Mechanical	Input Power kW	0.08	0.11	0.17	0.20	0.28
				Output Torque Nm	141.	258.	425.	603.	950.
			Thermal	Input Power kW	0.38	0.40	0.74	0.69	1.00
				Output Torque Nm	1040.	1150.	2480.	2630.	4110.
	1750.	0.83	Mechanical	Input Power kW	0.09	0.10	0.18	0.19	0.27
				Output Torque Nm	189.	203.	501.	603.	950.
			Thermal	Input Power kW	0.23	0.25	0.47	0.36	0.51
				Output Torque Nm	590.	657.	1630.	1310.	2010.
	1800.	0.81	Mechanical	Input Power kW	0.09	0.12	0.18	0.19	0.26
				Output Torque Nm	189.	297.	501.	603.	950.
			Thermal	Input Power kW	0.27	0.30	0.56	0.42	0.62
				Output Torque Nm	770.	876.	1920.	1590.	2630.
2000.	0.73	Mechanical	Input Power kW	0.07	0.10	0.15	0.17	0.25	
			Output Torque Nm	143.	262.	432.	603.	950.	
		Thermal	Input Power kW	0.33	0.34	0.68	0.52	0.72	
			Output Torque Nm	1050.	1170.	2690.	2310.	3330.	
2100.	0.69	Mechanical	Input Power kW	0.09	0.10	0.16	0.17	0.24	
			Output Torque Nm	189.	237.	501.	603.	950.	
		Thermal	Input Power kW	0.23	0.25	0.47	0.36	0.51	
			Output Torque Nm	669.	764.	1840.	1520.	2340.	
2400.	0.60	Mechanical	Input Power kW	0.07	0.10	0.15	0.17	0.22	
			Output Torque Nm	145.	265.	437.	603.	950.	
		Thermal	Input Power kW	0.27	0.30	0.56	0.42	0.62	
			Output Torque Nm	946.	1100.	2350.	1970.	3260.	
2500.	0.58	Mechanical	Input Power kW	0.05	0.07	0.11	0.14	0.20	
			Output Torque Nm	103.	188.	312.	545.	854.	
		Thermal	Input Power kW	0.33	0.34	0.64	0.52	0.72	
			Output Torque Nm	1250.	1320.	2960.	2760.	3880.	
2800.	0.52	Mechanical	Input Power kW	0.07	0.09	0.13	0.15	0.20	
			Output Torque Nm	146.	268.	442.	603.	950.	
		Thermal	Input Power kW	0.23	0.25	0.47	0.36	0.51	
			Output Torque Nm	823.	961.	2260.	1880.	2900.	
3000.	0.48	Mechanical	Input Power kW	0.05	0.07	0.11	0.14	0.19	
			Output Torque Nm	104.	190.	316.	552.	864.	
		Thermal	Input Power kW	0.27	0.30	0.56	0.42	0.62	
			Output Torque Nm	1120.	1250.	2730.	2350.	3800.	
3500.	0.41	Mechanical	Input Power kW	0.05	0.07	0.10	0.13	0.17	
			Output Torque Nm	105.	192.	319.	557.	872.	
		Thermal	Input Power kW	0.23	0.25	0.47	0.36	0.51	
			Output Torque Nm	975.	1090.	2620.	2240.	3380.	
3600.	0.40	Mechanical	Input Power kW	0.05	0.06	0.09	0.11	0.14	
			Output Torque Nm	80.	146.	242.	419.	653.	
		Thermal	Input Power kW	0.27	0.30	0.56	0.42	0.62	
			Output Torque Nm	1180.	1420.	3120.	2590.	4280.	
4200.	0.35	Mechanical	Input Power kW	0.05	0.06	0.08	0.10	0.13	
			Output Torque Nm	80.	148.	244.	423.	659.	
		Thermal	Input Power kW	0.23	0.25	0.47	0.36	0.51	
			Output Torque Nm	1030.	1240.	2990.	2470.	3800.	
			Efficiency %	6	9	11	15	18	

SERIES AJ

RATINGS AT 1160 REV/MIN INPUT

	NOMINAL RATIO	NOMINAL OUTPUT SPEED REV / MIN	CAPACITY		SIZE OF UNIT					
					A0280	A0410	A0510	A0610	A0730	A0860
SINGLE REDUCTION	5.0	232.00	Mechanical	Input Power kW	0.59	1.34	2.89	4.34	6.17	10.70
				Output Torque Nm	22.	51.	103.	162.	246.	400.
			Thermal	Input Power kW	1.46	2.22	3.62	5.12	10.40	12.70
				Output Torque Nm	56.	85.	129.	191.	414.	475.
			Efficiency %	87	88	90	91	93	94	
	7.5	154.67	Mechanical	Input Power kW	0.53	1.17	2.02	3.12	4.70	7.15
				Output Torque Nm	27.	61.	107.	167.	257.	394.
			Thermal	Input Power kW	1.19	1.86	2.96	4.35	8.98	10.80
				Output Torque Nm	61.	97.	157.	234.	495.	598.
			Efficiency %	84	86	88	89	92	92	
	10.0	116.00	Mechanical	Input Power kW	0.48	1.16	2.03	2.76	3.87	6.26
				Output Torque Nm	33.	83.	148.	191.	296.	453.
			Thermal	Input Power kW	0.92	1.50	2.30	3.76	7.43	9.07
				Output Torque Nm	64.	108.	168.	261.	574.	659.
			Efficiency %	80	82	84	87	90	91	
	12.5	92.80	Mechanical	Input Power kW	0.43	1.07	1.78	2.81	4.14	5.62
				Output Torque Nm	34.	88.	151.	243.	376.	526.
			Thermal	Input Power kW	0.77	1.29	2.06	3.03	6.02	8.06
				Output Torque Nm	62.	107.	175.	262.	549.	759.
			Efficiency %	76	80	82	84	88	90	
15.0	77.33	Mechanical	Input Power kW	0.39	1.02	1.59	2.40	3.69	5.60	
			Output Torque Nm	36.	96.	155.	244.	384.	589.	
		Thermal	Input Power kW	0.76	1.18	2.00	2.71	5.64	6.76	
			Output Torque Nm	70.	111.	197.	276.	591.	712.	
		Efficiency %	76	79	82	82	87	88		
20.0	58.00	Mechanical	Input Power kW	0.34	0.78	1.52	2.42	2.75	4.14	
			Output Torque Nm	37.	95.	185.	304.	374.	569.	
		Thermal	Input Power kW	0.52	1.10	1.34	1.98	4.75	5.67	
			Output Torque Nm	57.	136.	163.	247.	653.	783.	
		Efficiency %	66	76	74	76	85	86		
25.0	46.40	Mechanical	Input Power kW	0.31	0.77	1.28	2.01	2.78	3.98	
			Output Torque Nm	40.	109.	186.	303.	454.	657.	
		Thermal	Input Power kW	0.47	0.80	1.21	1.76	3.38	4.02	
			Output Torque Nm	63.	113.	176.	265.	554.	664.	
		Efficiency %	63	69	71	73	79	80		
30.0	38.67	Mechanical	Input Power kW	0.25	0.68	1.05	1.62	2.35	3.55	
			Output Torque Nm	38.	110.	179.	281.	450.	692.	
		Thermal	Input Power kW	0.44	0.73	1.14	1.60	3.13	3.74	
			Output Torque Nm	67.	119.	193.	276.	604.	729.	
		Efficiency %	60	66	69	70	78	79		
40.0	29.00	Mechanical	Input Power kW	0.19	0.50	0.80	1.20	1.71	2.60	
			Output Torque Nm	32.	101.	170.	260.	414.	642.	
		Thermal	Input Power kW	0.37	0.65	1.03	1.40	2.69	3.22	
			Output Torque Nm	65.	133.	223.	305.	660.	800.	
		Efficiency %	51	61	65	66	74	75		
50.0	23.20	Mechanical	Input Power kW	0.13	0.34	0.59	0.94	1.34	1.97	
			Output Torque Nm	26.	79.	145.	238.	390.	577.	
		Thermal	Input Power kW	0.30	0.50	0.75	1.04	2.02	2.32	
			Output Torque Nm	62.	120.	186.	265.	595.	683.	
		Efficiency %	48	57	60	62	71	71		
60.0	19.33	Mechanical	Input Power kW	0.09	0.25	0.41	0.65	0.99	1.50	
			Output Torque Nm	20.	61.	112.	186.	322.	502.	
		Thermal	Input Power kW	0.25	0.41	0.65	0.90	1.64	1.93	
			Output Torque Nm	57.	105.	185.	263.	549.	653.	
		Efficiency %	42	50	56	58	66	68		
70.0	16.57	Mechanical	Input Power kW	0.07	0.18	0.29	0.49	0.71	1.12	
			Output Torque Nm	16.	50.	88.	150.	253.	411.	
		Thermal	Input Power kW	0.21	0.34	0.53	0.71	1.28	1.50	
			Output Torque Nm	51.	102.	168.	226.	470.	561.	
		Efficiency %	38	48	52	53	62	64		

SERIES AJ

RATINGS AT 1160 REV/MIN INPUT

	NOMINAL RATIO	NOMINAL OUTPUT SPEED REV / MIN	CAPACITY		SIZE OF UNIT				
					A0410	A0510	A0610	A0730	A0860
SINGLE REDUCTION	75.0	15.47	Mechanical	Input Power kW	0.40	0.54	0.94	1.17	2.22
				Output Torque Nm	158.	226.	406.	526.	950.
			Thermal	Input Power kW	0.70	1.26	1.63	2.16	2.49
				Output Torque Nm	279.	535.	715.	992.	1070.
			Efficiency %	63	66	66	72	75	
			100.	11.60	Mechanical	Input Power kW	0.25	0.54	0.91
	Output Torque Nm	125.				270.	468.	603.	921.
	Thermal	Input Power kW			0.67	0.81	1.17	1.96	2.13
		Output Torque Nm			355.	405.	610.	1160.	1180.
	Efficiency %	60			58	59	69	72	
	125.	9.28			Mechanical	Input Power kW	0.30	0.50	0.80
			Output Torque Nm	172.		297.	487.	603.	950.
			Thermal	Input Power kW	0.48	0.72	1.04	1.44	1.56
				Output Torque Nm	277.	430.	639.	984.	1000.
			Efficiency %	53	55	56	62	65	
			150.	7.73	Mechanical	Input Power kW	0.27	0.36	0.61
	Output Torque Nm	184.				268.	474.	603.	950.
	Thermal	Input Power kW			0.61	0.91	1.38	1.46	1.98
		Output Torque Nm			436.	691.	1110.	1220.	1690.
	Efficiency %	55			59	60	65	67	
	200.	5.80			Mechanical	Input Power kW	0.16	0.36	0.55
			Output Torque Nm	133.		309.	501.	603.	950.
			Thermal	Input Power kW	0.59	0.70	0.99	1.46	1.70
				Output Torque Nm	560.	627.	931.	1580.	1880.
			Efficiency %	51	50	53	62	64	
			225.	5.16	Mechanical	Input Power kW	0.21	0.30	0.51
	Output Torque Nm	189.				282.	501.	603.	950.
	Thermal	Input Power kW			0.58	0.75	1.32	1.15	1.79
Output Torque Nm		540.			738.	1370.	1240.	2030.	
Efficiency %	51	55			55	60	64		
250.	4.64	Mechanical			Input Power kW	0.20	0.30	0.47	0.51
			Output Torque Nm	189.	309.	501.	603.	950.	
		Thermal	Input Power kW	0.42	0.63	0.88	1.27	1.26	
			Output Torque Nm	428.	668.	976.	1570.	1580.	
		Efficiency %	45	47	49	55	57		
		300.	3.87	Mechanical	Input Power kW	0.19	0.26	0.39	0.45
Output Torque Nm	189.				285.	501.	603.	950.	
Thermal	Input Power kW			0.48	0.50	1.24	1.07	1.20	
	Output Torque Nm			524.	573.	1680.	1510.	1650.	
Efficiency %	42			46	53	58	56		
350.	3.31			Mechanical	Input Power kW	0.15	0.24	0.37	0.41
		Output Torque Nm	189.		309.	501.	603.	466.	
		Thermal	Input Power kW	0.40	0.61	0.84	1.15	0.66	
			Output Torque Nm	530.	825.	1200.	1830.	884.	
		Efficiency %	41	44	45	50	46		
		375.	3.09	Mechanical	Input Power kW	0.06	0.09	0.17	0.23
Output Torque Nm	57.				100.	171.	288.	950.	
Thermal	Input Power kW			0.25	0.39	0.56	0.62	1.18	
	Output Torque Nm			295.	484.	681.	875.	1950.	
Efficiency %	30			35	33	41	54		
400.	2.90			Mechanical	Input Power kW	0.11	0.24	0.34	0.36
		Output Torque Nm	138.		309.	501.	603.	950.	
		Thermal	Input Power kW	0.48	0.50	0.89	1.07	1.20	
			Output Torque Nm	689.	668.	1400.	1950.	2120.	
		Efficiency %	38	39	46	54	52		
		450.	2.58	Mechanical	Input Power kW	0.14	0.21	0.33	0.35
Output Torque Nm	189.				309.	501.	603.	950.	
Thermal	Input Power kW			0.38	0.60	0.79	1.15	1.12	
	Output Torque Nm			564.	946.	1270.	2130.	2150.	
Efficiency %	38			42	42	48	52		
500.	2.32			Mechanical	Input Power kW	0.14	0.21	0.29	0.32
		Output Torque Nm	189.		309.	501.	603.	950.	
		Thermal	Input Power kW	0.42	0.50	0.79	1.07	1.20	
			Output Torque Nm	664.	791.	1460.	2210.	2410.	
		Efficiency %	33	36	43	47	46		
		600.	1.93	Mechanical	Input Power kW	0.12	0.18	0.26	0.28
Output Torque Nm	189.				309.	501.	603.	950.	
Thermal	Input Power kW			0.40	0.50	0.74	1.07	1.18	
	Output Torque Nm			707.	919.	1560.	2580.	2760.	
Efficiency %	31			34	40	45	44		
625.	1.86			Mechanical	Input Power kW	0.12	0.18	0.27	0.29
		Output Torque Nm	189.		309.	501.	603.	950.	
		Thermal	Input Power kW	0.42	0.46	0.83	0.77	1.08	
			Output Torque Nm	777.	859.	1740.	1780.	2570.	
		Efficiency %	31	34	36	41	43		
		700.	1.66	Mechanical	Input Power kW	0.08	0.08	0.19	0.18
Output Torque Nm	119.				115.	359.	391.	674.	
Thermal	Input Power kW			0.21	0.22	0.44	0.34	0.47	
	Output Torque Nm			371.	410.	961.	800.	1140.	
Efficiency %	24			24	35	36	41		
750.	1.55			Mechanical	Input Power kW	0.11	0.16	0.24	0.25
		Output Torque Nm	189.		309.	501.	603.	950.	
		Thermal	Input Power kW	0.39	0.46	0.77	0.77	1.08	
			Output Torque Nm	829.	999.	1840.	2080.	3000.	
		Efficiency %	29	32	34	38	41		
		800.	1.45	Mechanical	Input Power kW	0.08	0.16	0.23	0.24
Output Torque Nm	143.				309.	501.	603.	950.	
Thermal	Input Power kW			0.34	0.35	0.71	0.63	0.92	
	Output Torque Nm			755.	724.	1780.	1800.	2840.	
Efficiency %	26			29	34	40	44		

SERIES AJ

RATINGS AT 1160 REV/MIN INPUT

NOMINAL RATIO	NOMINAL OUTPUT SPEED REV / MIN	CAPACITY		SIZE OF UNIT					
				A0410	A0510	A0610	A0730	A0860	
900.	1.29	Mechanical	Input Power kW	0.10	0.14	0.21	0.23	0.33	
			Output Torque Nm	189.	309.	501.	603.	950.	
		Thermal	Input Power kW	0.39	0.43	0.77	0.71	1.02	
			Output Torque Nm	946.	1060.	2090.	2160.	3280.	
				Efficiency %	27	30	32	36	39
				Input Power kW	0.10	0.14	0.20	0.21	0.31
1000.	1.16	Mechanical	Output Torque Nm	189.	309.	501.	603.	950.	
			Input Power kW	0.34	0.35	0.71	0.63	0.92	
		Thermal	Output Torque Nm	813.	854.	2090.	2020.	3190.	
			Efficiency %	24	26	31	34	38	
				Input Power kW	0.09	0.13	0.18	0.19	0.27
		1200.	0.97	Mechanical	Output Torque Nm	189.	309.	501.	603.
Input Power kW	0.34				0.35	0.71	0.63	0.92	
Thermal	Output Torque Nm			923.	993.	2370.	2360.	3730.	
	Efficiency %			21	25	28	32	36	
				Input Power kW	0.08	0.12	0.17	0.19	0.27
1250.	0.93			Mechanical	Output Torque Nm	189.	309.	501.	603.
		Input Power kW	0.29		0.30	0.61	0.49	0.67	
		Thermal	Output Torque Nm	828.	869.	2110.	1820.	2610.	
			Efficiency %	22	25	28	32	34	
				Input Power kW	0.07	0.08	0.16	0.17	0.24
		1400.	0.83	Mechanical	Output Torque Nm	147.	175.	501.	603.
Input Power kW	0.21				0.22	0.44	0.34	0.47	
Thermal	Output Torque Nm			620.	625.	1570.	1350.	2060.	
	Efficiency %			19	19	27	32	35	
				Input Power kW	0.08	0.11	0.16	0.16	0.24
1500.	0.77			Mechanical	Output Torque Nm	189.	309.	501.	603.
		Input Power kW	0.29		0.30	0.61	0.49	0.67	
		Thermal	Output Torque Nm	939.	1010.	2390.	2120.	3040.	
			Efficiency %	20	23	26	30	32	
				Input Power kW	0.06	0.09	0.14	0.16	0.22
		1600.	0.73	Mechanical	Output Torque Nm	143.	262.	432.	603.
Input Power kW	0.34				0.35	0.70	0.63	0.92	
Thermal	Output Torque Nm			1140.	1250.	2900.	2920.	4630.	
	Efficiency %			17	21	24	29	32	
				Input Power kW	0.08	0.08	0.15	0.16	0.22
1750.	0.66			Mechanical	Output Torque Nm	189.	207.	501.	603.
		Input Power kW	0.21		0.22	0.44	0.34	0.47	
		Thermal	Output Torque Nm	665.	737.	1850.	1510.	2300.	
			Efficiency %	17	18	24	27	30	
				Input Power kW	0.07	0.10	0.15	0.16	0.21
		1800.	0.64	Mechanical	Output Torque Nm	189.	302.	501.	603.
Input Power kW	0.25				0.27	0.51	0.39	0.58	
Thermal	Output Torque Nm			860.	958.	2140.	1820.	3000.	
	Efficiency %			17	20	23	26	30	
				Input Power kW	0.06	0.08	0.12	0.14	0.20
2000.	0.58			Mechanical	Output Torque Nm	145.	266.	438.	603.
		Input Power kW	0.29		0.30	0.61	0.49	0.67	
		Thermal	Output Torque Nm	1160.	1270.	2940.	2630.	3770.	
			Efficiency %	16	20	22	26	29	
				Input Power kW	0.07	0.08	0.13	0.14	0.19
		2100.	0.55	Mechanical	Output Torque Nm	189.	240.	501.	603.
Input Power kW	0.21				0.22	0.44	0.34	0.47	
Thermal	Output Torque Nm			753.	857.	2100.	1760.	2690.	
	Efficiency %			16	17	22	25	28	
				Input Power kW	0.06	0.08	0.12	0.13	0.18
2400.	0.48			Mechanical	Output Torque Nm	147.	269.	444.	603.
		Input Power kW	0.25		0.27	0.51	0.39	0.58	
		Thermal	Output Torque Nm	1060.	1210.	2620.	2260.	3710.	
			Efficiency %	13	17	19	23	27	
				Input Power kW	0.04	0.06	0.09	0.12	0.17
		2500.	0.46	Mechanical	Output Torque Nm	104.	191.	317.	553.
Input Power kW	0.29				0.30	0.61	0.49	0.67	
Thermal	Output Torque Nm			1370.	1440.	3400.	3130.	4400.	
	Efficiency %			12	15	17	23	25	
				Input Power kW	0.05	0.07	0.11	0.12	0.16
2800.	0.41			Mechanical	Output Torque Nm	148.	272.	448.	603.
		Input Power kW	0.21		0.22	0.44	0.34	0.47	
		Thermal	Output Torque Nm	926.	1080.	2570.	2170.	3320.	
			Efficiency %	12	16	18	22	25	
				Input Power kW	0.04	0.06	0.09	0.11	0.15
		3000.	0.39	Mechanical	Output Torque Nm	106.	193.	321.	559.
Input Power kW	0.25				0.27	0.51	0.39	0.58	
Thermal	Output Torque Nm			1250.	1360.	3040.	2690.	4320.	
	Efficiency %			10	13	15	20	23	
				Input Power kW	0.04	0.06	0.08	0.10	0.14
3500.	0.33			Mechanical	Output Torque Nm	107.	195.	324.	565.
		Input Power kW	0.21		0.22	0.44	0.34	0.47	
		Thermal	Output Torque Nm	1100.	1220.	2980.	2590.	3870.	
			Efficiency %	9	12	14	19	22	
				Input Power kW	0.04	0.05	0.07	0.09	0.12
		3600.	0.32	Mechanical	Output Torque Nm	81.	148.	245.	425.
Input Power kW	0.25				0.27	0.51	0.39	0.58	
Thermal	Output Torque Nm			1320.	1560.	3470.	2960.	4860.	
	Efficiency %			7	10	11	16	19	
				Input Power kW	0.04	0.05	0.07	0.08	0.11
4200.	0.28			Mechanical	Output Torque Nm	81.	150.	247.	428.
		Input Power kW	0.21		0.22	0.44	0.34	0.47	
		Thermal	Output Torque Nm	1150.	1390.	3400.	2850.	4350.	
			Efficiency %	6	9	11	15	18	

SINGLE REDUCTION

SERIES AJ

RATINGS AT 960 REV/MIN INPUT

	NOMINAL RATIO	NOMINAL OUTPUT SPEED REV / MIN	CAPACITY		SIZE OF UNIT					
					A0280	A0410	A0510	A0610	A0730	A0860
SINGLE REDUCTION	5.0	192.00	Mechanical	Input Power kW	0.53	1.20	2.60	3.91	5.55	9.66
				Output Torque Nm	24.	55.	111.	175.	266.	434.
			Thermal	Input Power kW	1.32	2.05	3.31	4.71	8.97	10.90
				Output Torque Nm	61.	95.	142.	211.	432.	490.
			Efficiency %	87	87	89	90	93	93	
	7.5	128.00	Mechanical	Input Power kW	0.47	1.05	1.81	2.79	4.20	6.40
				Output Torque Nm	29.	65.	115.	180.	277.	425.
			Thermal	Input Power kW	1.08	1.72	2.73	4.02	7.79	9.28
				Output Torque Nm	67.	108.	174.	260.	516.	618.
			Efficiency %	84	85	87	88	91	92	
	10.0	96.00	Mechanical	Input Power kW	0.43	1.03	1.81	2.46	3.45	5.58
				Output Torque Nm	35.	89.	158.	204.	318.	486.
			Thermal	Input Power kW	0.83	1.39	2.13	3.48	6.45	7.80
				Output Torque Nm	70.	120.	187.	291.	599.	681.
			Efficiency %	79	82	84	86	90	91	
	12.5	76.80	Mechanical	Input Power kW	0.39	0.95	1.59	2.50	3.69	5.01
				Output Torque Nm	36.	94.	162.	260.	403.	564.
			Thermal	Input Power kW	0.71	1.20	1.90	2.81	5.24	6.94
				Output Torque Nm	68.	120.	194.	292.	574.	784.
			Efficiency %	76	80	82	84	88	89	
	15.0	64.00	Mechanical	Input Power kW	0.35	0.91	1.41	2.14	3.29	4.99
				Output Torque Nm	38.	102.	166.	261.	412.	631.
			Thermal	Input Power kW	0.70	1.10	1.85	2.52	4.91	5.83
				Output Torque Nm	77.	124.	218.	307.	617.	737.
		Efficiency %	76	78	82	82	87	88		
20.0	48.00	Mechanical	Input Power kW	0.31	0.69	1.36	2.17	2.45	3.69	
			Output Torque Nm	40.	102.	198.	325.	400.	609.	
		Thermal	Input Power kW	0.47	1.02	1.25	1.85	4.14	4.89	
			Output Torque Nm	61.	152.	181.	276.	682.	810.	
		Efficiency %	65	76	73	75	84	85		
25.0	38.40	Mechanical	Input Power kW	0.28	0.69	1.14	1.80	2.48	3.55	
			Output Torque Nm	43.	116.	198.	323.	485.	703.	
		Thermal	Input Power kW	0.43	0.74	1.13	1.65	2.95	3.48	
			Output Torque Nm	68.	126.	195.	296.	579.	688.	
		Efficiency %	62	68	69	72	79	80		
30.0	32.00	Mechanical	Input Power kW	0.23	0.60	0.94	1.45	2.10	3.18	
			Output Torque Nm	40.	117.	190.	300.	480.	739.	
		Thermal	Input Power kW	0.40	0.68	1.06	1.49	2.74	3.24	
			Output Torque Nm	73.	132.	215.	308.	631.	756.	
		Efficiency %	59	65	68	69	77	78		
40.0	24.00	Mechanical	Input Power kW	0.16	0.45	0.71	1.07	1.52	2.32	
			Output Torque Nm	33.	107.	180.	276.	441.	684.	
		Thermal	Input Power kW	0.33	0.61	0.96	1.31	2.36	2.79	
			Output Torque Nm	70.	148.	248.	340.	690.	828.	
		Efficiency %	51	60	64	65	73	74		
50.0	19.20	Mechanical	Input Power kW	0.11	0.29	0.51	0.82	1.19	1.75	
			Output Torque Nm	26.	81.	148.	246.	414.	613.	
		Thermal	Input Power kW	0.27	0.47	0.70	0.98	1.77	2.02	
			Output Torque Nm	68.	134.	207.	297.	623.	709.	
		Efficiency %	47	56	59	61	70	70		
60.0	16.00	Mechanical	Input Power kW	0.08	0.21	0.35	0.56	0.84	1.29	
			Output Torque Nm	20.	62.	115.	189.	328.	512.	
		Thermal	Input Power kW	0.23	0.38	0.61	0.85	1.45	1.69	
			Output Torque Nm	63.	118.	207.	296.	576.	679.	
		Efficiency %	42	49	55	57	65	67		
70.0	13.71	Mechanical	Input Power kW	0.06	0.16	0.25	0.42	0.61	0.96	
			Output Torque Nm	16.	51.	90.	153.	258.	419.	
		Thermal	Input Power kW	0.19	0.32	0.50	0.67	1.13	1.32	
			Output Torque Nm	56.	114.	188.	255.	494.	584.	
		Efficiency %	38	47	52	53	61	63		

SERIES AJ

RATINGS AT 960 REV/MIN INPUT

	NOMINAL RATIO	NOMINAL OUTPUT SPEED REV / MIN	CAPACITY		SIZE OF UNIT				
					A0410	A0510	A0610	A0730	A0860
SINGLE REDUCTION	75.0	12.80	Mechanical	Input Power kW	0.35	0.49	0.83	1.04	1.86
				Output Torque Nm	165.	242.	425.	564.	950.
			Thermal	Input Power kW	0.65	1.19	1.54	1.99	2.26
				Output Torque Nm	313.	601.	807.	1090.	1160.
	100.	9.60	Mechanical	Input Power kW	0.21	0.49	0.79	0.87	1.44
				Output Torque Nm	127.	288.	485.	603.	950.
			Thermal	Input Power kW	0.63	0.76	1.10	1.85	1.94
				Output Torque Nm	399.	454.	682.	1310.	1280.
	125.	7.68	Mechanical	Input Power kW	0.26	0.44	0.69	0.75	1.25
				Output Torque Nm	179.	309.	501.	603.	950.
			Thermal	Input Power kW	0.45	0.68	0.97	1.36	1.42
				Output Torque Nm	310.	485.	714.	1110.	1080.
	150.	6.40	Mechanical	Input Power kW	0.23	0.31	0.53	0.62	0.95
				Output Torque Nm	189.	276.	492.	603.	950.
			Thermal	Input Power kW	0.58	0.82	1.31	1.35	1.87
				Output Torque Nm	494.	741.	1260.	1350.	1910.
	200.	4.80	Mechanical	Input Power kW	0.13	0.30	0.46	0.49	0.74
				Output Torque Nm	134.	309.	501.	603.	950.
			Thermal	Input Power kW	0.56	0.67	0.94	1.35	1.62
				Output Torque Nm	636.	709.	1050.	1750.	2130.
	225.	4.27	Mechanical	Input Power kW	0.18	0.25	0.42	0.49	0.72
				Output Torque Nm	189.	285.	501.	603.	950.
			Thermal	Input Power kW	0.55	0.68	1.20	1.07	1.66
				Output Torque Nm	616.	797.	1490.	1370.	2240.
	250.	3.84	Mechanical	Input Power kW	0.16	0.26	0.39	0.43	0.65
				Output Torque Nm	189.	309.	501.	603.	950.
			Thermal	Input Power kW	0.40	0.60	0.83	1.19	1.20
				Output Torque Nm	485.	755.	1100.	1760.	1780.
300.	3.20	Mechanical	Input Power kW	0.16	0.22	0.33	0.38	0.60	
			Output Torque Nm	189.	284.	501.	603.	950.	
		Thermal	Input Power kW	0.43	0.45	1.13	0.99	1.11	
			Output Torque Nm	566.	616.	1830.	1670.	1820.	
350.	2.74	Mechanical	Input Power kW	0.13	0.20	0.31	0.34	0.31	
			Output Torque Nm	189.	309.	501.	603.	471.	
		Thermal	Input Power kW	0.38	0.58	0.80	1.07	0.60	
			Output Torque Nm	604.	938.	1360.	2020.	962.	
375.	2.56	Mechanical	Input Power kW	0.05	0.08	0.14	0.20	0.50	
			Output Torque Nm	58.	101.	173.	291.	950.	
		Thermal	Input Power kW	0.24	0.37	0.54	0.59	1.14	
			Output Torque Nm	340.	559.	786.	990.	2250.	
400.	2.40	Mechanical	Input Power kW	0.10	0.20	0.29	0.30	0.48	
			Output Torque Nm	140.	309.	501.	603.	950.	
		Thermal	Input Power kW	0.43	0.45	0.85	0.99	1.11	
			Output Torque Nm	744.	716.	1590.	2150.	2350.	
450.	2.13	Mechanical	Input Power kW	0.12	0.17	0.28	0.30	0.43	
			Output Torque Nm	189.	309.	501.	603.	950.	
		Thermal	Input Power kW	0.36	0.57	0.75	1.07	1.08	
			Output Torque Nm	644.	1080.	1450.	2350.	2490.	
500.	1.92	Mechanical	Input Power kW	0.12	0.18	0.25	0.27	0.42	
			Output Torque Nm	189.	309.	501.	603.	950.	
		Thermal	Input Power kW	0.41	0.45	0.75	0.99	1.11	
			Output Torque Nm	759.	846.	1670.	2440.	2660.	
600.	1.60	Mechanical	Input Power kW	0.10	0.15	0.22	0.23	0.37	
			Output Torque Nm	189.	309.	501.	603.	950.	
		Thermal	Input Power kW	0.38	0.45	0.71	0.99	1.11	
			Output Torque Nm	809.	984.	1770.	2840.	3110.	
625.	1.54	Mechanical	Input Power kW	0.10	0.15	0.22	0.24	0.36	
			Output Torque Nm	189.	309.	501.	603.	950.	
		Thermal	Input Power kW	0.40	0.41	0.79	0.70	1.00	
			Output Torque Nm	880.	921.	1970.	1920.	2840.	
700.	1.37	Mechanical	Input Power kW	0.07	0.07	0.16	0.16	0.25	
			Output Torque Nm	121.	117.	364.	397.	684.	
		Thermal	Input Power kW	0.19	0.21	0.41	0.32	0.45	
			Output Torque Nm	411.	452.	1070.	902.	1280.	
750.	1.28	Mechanical	Input Power kW	0.09	0.13	0.20	0.21	0.32	
			Output Torque Nm	189.	309.	501.	603.	950.	
		Thermal	Input Power kW	0.38	0.41	0.74	0.70	1.00	
			Output Torque Nm	951.	1070.	2100.	2230.	3320.	
800.	1.20	Mechanical	Input Power kW	0.07	0.14	0.19	0.20	0.28	
			Output Torque Nm	144.	309.	501.	603.	950.	
		Thermal	Input Power kW	0.31	0.32	0.64	0.57	0.86	
			Output Torque Nm	816.	779.	1910.	1960.	3150.	
			Efficiency %	26	28	33	39	43	

SERIES AJ

RATINGS AT 960 REV/MIN INPUT

	NOMINAL RATIO	NOMINAL OUTPUT SPEED REV / MIN	CAPACITY		SIZE OF UNIT					
					A0410	A0510	A0610	A0730	A0860	
SINGLE REDUCTION	900.	1.07	Mechanical	Input Power kW	0.08	0.12	0.18	0.19	0.28	
				Output Torque Nm	189.	309.	501.	603.	950.	
			Thermal	Input Power kW	0.37	0.39	0.72	0.64	0.95	
				Output Torque Nm	1060.	1140.	2330.	2330.	3620.	
					Efficiency %	26	30	31	35	38
					Efficiency %	26	30	31	35	38
	1000.	0.96	Mechanical	Input Power kW	0.08	0.12	0.17	0.18	0.26	
				Output Torque Nm	189.	309.	501.	603.	950.	
			Thermal	Input Power kW	0.31	0.32	0.64	0.57	0.86	
				Output Torque Nm	878.	918.	2250.	2190.	3530.	
					Efficiency %	23	26	30	34	37
					Efficiency %	23	26	30	34	37
	1200.	0.80	Mechanical	Input Power kW	0.07	0.11	0.15	0.16	0.23	
				Output Torque Nm	189.	309.	501.	603.	950.	
			Thermal	Input Power kW	0.31	0.32	0.64	0.57	0.86	
				Output Torque Nm	996.	1070.	2560.	2550.	4120.	
					Efficiency %	21	24	28	32	35
					Efficiency %	21	24	28	32	35
	1250.	0.77	Mechanical	Input Power kW	0.07	0.10	0.14	0.16	0.23	
				Output Torque Nm	189.	309.	501.	603.	950.	
			Thermal	Input Power kW	0.27	0.28	0.55	0.45	0.62	
				Output Torque Nm	895.	938.	2280.	2030.	2900.	
					Efficiency %	22	24	28	31	34
					Efficiency %	22	24	28	31	34
	1400.	0.69	Mechanical	Input Power kW	0.06	0.07	0.14	0.14	0.20	
				Output Torque Nm	149.	178.	501.	603.	950.	
			Thermal	Input Power kW	0.19	0.21	0.41	0.32	0.45	
				Output Torque Nm	685.	688.	1750.	1520.	2310.	
					Efficiency %	19	19	26	31	35
					Efficiency %	19	19	26	31	35
	1500.	0.64	Mechanical	Input Power kW	0.06	0.09	0.13	0.14	0.20	
				Output Torque Nm	189.	309.	501.	603.	950.	
			Thermal	Input Power kW	0.27	0.28	0.55	0.45	0.62	
				Output Torque Nm	1010.	1090.	2590.	2360.	3380.	
					Efficiency %	20	23	26	29	32
					Efficiency %	20	23	26	29	32
1600.	0.60	Mechanical	Input Power kW	0.05	0.08	0.12	0.13	0.19		
			Output Torque Nm	145.	265.	437.	603.	950.		
		Thermal	Input Power kW	0.31	0.32	0.64	0.57	0.86		
			Output Torque Nm	1220.	1340.	3140.	3160.	5110.		
				Efficiency %	17	21	24	28	32	
				Efficiency %	17	21	24	28	32	
1750.	0.55	Mechanical	Input Power kW	0.06	0.07	0.12	0.13	0.19		
			Output Torque Nm	189.	209.	501.	603.	950.		
		Thermal	Input Power kW	0.19	0.21	0.41	0.32	0.45		
			Output Torque Nm	733.	811.	2060.	1690.	2580.		
				Efficiency %	17	18	24	26	29	
				Efficiency %	17	18	24	26	29	
1800.	0.53	Mechanical	Input Power kW	0.06	0.09	0.13	0.13	0.18		
			Output Torque Nm	189.	306.	501.	603.	950.		
		Thermal	Input Power kW	0.23	0.24	0.46	0.37	0.54		
			Output Torque Nm	944.	1040.	2310.	2040.	3340.		
				Efficiency %	17	20	22	26	30	
				Efficiency %	17	20	22	26	30	
2000.	0.48	Mechanical	Input Power kW	0.05	0.07	0.10	0.12	0.17		
			Output Torque Nm	147.	269.	444.	603.	950.		
		Thermal	Input Power kW	0.27	0.28	0.55	0.45	0.62		
			Output Torque Nm	1250.	1370.	3180.	2920.	4190.		
				Efficiency %	16	20	22	26	28	
				Efficiency %	16	20	22	26	28	
2100.	0.46	Mechanical	Input Power kW	0.06	0.07	0.11	0.12	0.16		
			Output Torque Nm	189.	243.	501.	603.	950.		
		Thermal	Input Power kW	0.19	0.21	0.41	0.32	0.45		
			Output Torque Nm	831.	942.	2340.	1970.	3010.		
				Efficiency %	16	17	22	25	28	
				Efficiency %	16	17	22	25	28	
2400.	0.40	Mechanical	Input Power kW	0.05	0.07	0.10	0.11	0.15		
			Output Torque Nm	148.	272.	449.	603.	950.		
		Thermal	Input Power kW	0.23	0.24	0.46	0.37	0.54		
			Output Torque Nm	1160.	1300.	2840.	2520.	4130.		
				Efficiency %	13	17	19	23	26	
				Efficiency %	13	17	19	23	26	
2500.	0.38	Mechanical	Input Power kW	0.04	0.05	0.07	0.10	0.14		
			Output Torque Nm	106.	193.	321.	560.	876.		
		Thermal	Input Power kW	0.27	0.28	0.55	0.45	0.62		
			Output Torque Nm	1480.	1550.	3680.	3480.	4880.		
				Efficiency %	12	15	17	23	25	
				Efficiency %	12	15	17	23	25	
2800.	0.34	Mechanical	Input Power kW	0.04	0.06	0.09	0.10	0.14		
			Output Torque Nm	150.	275.	453.	603.	950.		
		Thermal	Input Power kW	0.19	0.21	0.41	0.32	0.45		
			Output Torque Nm	1020.	1180.	2870.	2440.	3720.		
				Efficiency %	12	16	18	22	25	
				Efficiency %	12	16	18	22	25	
3000.	0.32	Mechanical	Input Power kW	0.04	0.05	0.07	0.10	0.13		
			Output Torque Nm	107.	195.	324.	566.	886.		
		Thermal	Input Power kW	0.23	0.24	0.46	0.37	0.54		
			Output Torque Nm	1370.	1470.	3290.	3000.	4810.		
				Efficiency %	10	13	15	20	23	
				Efficiency %	10	13	15	20	23	
3500.	0.27	Mechanical	Input Power kW	0.03	0.05	0.07	0.09	0.12		
			Output Torque Nm	108.	197.	327.	571.	894.		
		Thermal	Input Power kW	0.19	0.21	0.41	0.32	0.45		
			Output Torque Nm	1210.	1340.	3320.	2900.	4330.		
				Efficiency %	9	12	14	19	22	
				Efficiency %	9	12	14	19	22	
3600.	0.27	Mechanical	Input Power kW	0.03	0.04	0.06	0.08	0.10		
			Output Torque Nm	82.	150.	248.	429.	669.		
		Thermal	Input Power kW	0.23	0.24	0.46	0.37	0.54		
			Output Torque Nm	1440.	1680.	3750.	3310.	5410.		
				Efficiency %	7	11	12	16	19	
				Efficiency %	7	11	12	16	19	
4200.	0.23	Mechanical	Input Power kW	0.03	0.04	0.05	0.07	0.09		
			Output Torque Nm	82.	151.	250.	433.	675.		
		Thermal	Input Power kW	0.19	0.21	0.41	0.32	0.45		
			Output Torque Nm	1270.	1530.	3790.	3190.	4860.		
				Efficiency %	6	10	11	15	18	
				Efficiency %	6	10	11	15	18	

SERIES AJ

RATINGS AT 725 REV/MIN INPUT

	NOMINAL RATIO	NOMINAL OUTPUT SPEED REV / MIN	CAPACITY		SIZE OF UNIT					
					A0280	A0410	A0510	A0610	A0730	A0860
SINGLE REDUCTION	5.0	145.00	Mechanical	Input Power kW	0.44	1.01	2.21	3.32	4.70	8.21
				Output Torque Nm	27.	61.	124.	195.	297.	486.
			Thermal	Input Power kW	1.14	1.81	2.91	4.17	7.24	8.66
				Output Torque Nm	69.	110.	164.	246.	459.	513.
		Efficiency %	86	87	89	89	92	93		
	7.5	96.67	Mechanical	Input Power kW	0.40	0.88	1.52	2.35	3.54	5.40
				Output Torque Nm	32.	72.	127.	199.	308.	472.
			Thermal	Input Power kW	0.94	1.53	2.42	3.58	6.30	7.40
				Output Torque Nm	76.	126.	203.	304.	550.	648.
		Efficiency %	83	85	87	88	91	92		
	10.0	72.50	Mechanical	Input Power kW	0.36	0.86	1.52	2.07	2.89	4.70
				Output Torque Nm	39.	97.	175.	226.	351.	539.
			Thermal	Input Power kW	0.73	1.24	1.89	3.11	5.23	6.24
				Output Torque Nm	80.	140.	218.	341.	638.	716.
		Efficiency %	79	82	83	86	89	90		
	12.5	58.00	Mechanical	Input Power kW	0.32	0.80	1.34	2.11	3.11	4.21
				Output Torque Nm	40.	103.	178.	287.	445.	623.
			Thermal	Input Power kW	0.61	1.07	1.69	2.52	4.26	5.56
				Output Torque Nm	76.	140.	226.	343.	612.	825.
		Efficiency %	75	79	81	83	87	89		
	15.0	48.33	Mechanical	Input Power kW	0.29	0.77	1.19	1.81	2.76	4.20
				Output Torque Nm	42.	112.	182.	287.	454.	697.
			Thermal	Input Power kW	0.61	0.98	1.65	2.26	3.99	4.68
				Output Torque Nm	88.	145.	255.	361.	659.	776.
		Efficiency %	75	77	80	80	86	87		
	20.0	36.25	Mechanical	Input Power kW	0.26	0.57	1.13	1.75	2.06	3.11
				Output Torque Nm	44.	110.	213.	340.	440.	671.
			Thermal	Input Power kW	0.40	0.91	1.12	1.67	3.38	3.93
Output Torque Nm				69.	178.	211.	324.	728.	853.	
	Efficiency %	64	75	72	74	83	84			
25.0	29.00	Mechanical	Input Power kW	0.23	0.58	0.96	1.52	2.09	3.00	
			Output Torque Nm	47.	127.	217.	355.	534.	774.	
		Thermal	Input Power kW	0.37	0.67	1.01	1.48	2.42	2.81	
			Output Torque Nm	76.	147.	228.	346.	619.	725.	
	Efficiency %	61	67	68	71	78	78			
30.0	24.17	Mechanical	Input Power kW	0.19	0.51	0.79	1.23	1.76	2.68	
			Output Torque Nm	44.	127.	208.	328.	526.	811.	
		Thermal	Input Power kW	0.35	0.61	0.95	1.35	2.25	2.63	
			Output Torque Nm	82.	155.	251.	363.	675.	796.	
	Efficiency %	58	63	66	67	76	77			
40.0	18.13	Mechanical	Input Power kW	0.13	0.37	0.59	0.90	1.28	1.95	
			Output Torque Nm	34.	115.	196.	300.	481.	747.	
		Thermal	Input Power kW	0.29	0.55	0.87	1.19	1.94	2.27	
			Output Torque Nm	78.	173.	290.	400.	737.	873.	
	Efficiency %	50	59	63	63	71	73			
50.0	14.50	Mechanical	Input Power kW	0.09	0.23	0.40	0.65	0.98	1.47	
			Output Torque Nm	27.	83.	152.	253.	442.	666.	
		Thermal	Input Power kW	0.24	0.42	0.63	0.89	1.47	1.65	
			Output Torque Nm	78.	158.	243.	351.	668.	750.	
	Efficiency %	47	55	57	59	69	69			
60.0	12.08	Mechanical	Input Power kW	0.06	0.17	0.28	0.44	0.67	1.02	
			Output Torque Nm	20.	64.	118.	195.	337.	526.	
		Thermal	Input Power kW	0.21	0.35	0.55	0.78	1.20	1.38	
			Output Torque Nm	72.	139.	243.	350.	619.	719.	
	Efficiency %	41	48	54	56	64	65			
70.0	10.36	Mechanical	Input Power kW	0.05	0.12	0.20	0.33	0.48	0.76	
			Output Torque Nm	16.	52.	92.	157.	265.	430.	
		Thermal	Input Power kW	0.17	0.30	0.45	0.62	0.94	1.08	
			Output Torque Nm	65.	136.	222.	303.	532.	620.	
	Efficiency %	37	46	51	51	60	61			

SERIES AJ

RATINGS AT 725 REV/MIN INPUT

	NOMINAL RATIO	NOMINAL OUTPUT SPEED REV / MIN	CAPACITY		SIZE OF UNIT				
					A0410	A0510	A0610	A0730	A0860
SINGLE REDUCTION	75.0	9.67	Mechanical	Input Power kW	0.29	0.40	0.68	0.68	1.43
				Output Torque Nm	176.	259.	452.	603.	950.
			Thermal	Input Power kW	0.60	1.09	1.41	1.76	2.07
				Output Torque Nm	377.	721.	962.	1260.	1380.
	100.	7.25	Mechanical	Input Power kW	0.17	0.40	0.63	0.67	1.11
				Output Torque Nm	130.	309.	501.	603.	950.
			Thermal	Input Power kW	0.58	0.70	1.00	1.74	1.78
				Output Torque Nm	479.	544.	809.	1600.	1530.
	125.	5.80	Mechanical	Input Power kW	0.22	0.34	0.53	0.58	0.97
				Output Torque Nm	189.	309.	501.	603.	950.
			Thermal	Input Power kW	0.41	0.63	0.89	1.27	1.30
				Output Torque Nm	371.	579.	848.	1350.	1290.
	150.	4.83	Mechanical	Input Power kW	0.18	0.25	0.42	0.4	8 0.73
				Output Torque Nm	189.	285.	501.	603.	950.
			Thermal	Input Power kW	0.54	0.71	1.22	1.20	1.69
				Output Torque Nm	598.	835.	1520.	1570.	2240.
	200.	3.63	Mechanical	Input Power kW	0.10	0.23	0.36	0.37	0.57
				Output Torque Nm	137.	309.	501.	603.	950.
			Thermal	Input Power kW	0.53	0.62	0.87	1.20	1.52
				Output Torque Nm	773.	855.	1260.	2020.	2600.
	225.	3.22	Mechanical	Input Power kW	0.14	0.19	0.33	0.37	0.56
				Output Torque Nm	189.	285.	501.	603.	950.
			Thermal	Input Power kW	0.52	0.59	1.04	0.92	1.48
				Output Torque Nm	752.	892.	1670.	1540.	2600.
	250.	2.90	Mechanical	Input Power kW	0.13	0.20	0.31	0.33	0.51
				Output Torque Nm	189.	309.	501.	603.	950.
			Thermal	Input Power kW	0.37	0.56	0.77	1.10	1.13
				Output Torque Nm	587.	911.	1330.	2090.	2180.
300.	2.42	Mechanical	Input Power kW	0.12	0.17	0.25	0.29	0.47	
			Output Torque Nm	189.	284.	501.	603.	950.	
		Thermal	Input Power kW	0.37	0.39	0.98	0.78	1.00	
			Output Torque Nm	632.	688.	2060.	1900.	2120.	
350.	2.07	Mechanical	Input Power kW	0.10	0.16	0.24	0.26	0.25	
			Output Torque Nm	189.	309.	501.	603.	478.	
		Thermal	Input Power kW	0.36	0.54	0.75	0.92	0.56	
			Output Torque Nm	737.	1140.	1650.	2250.	1160.	
375.	1.93	Mechanical	Input Power kW	0.04	0.06	0.11	0.15	0.39	
			Output Torque Nm	59.	103.	176.	296.	950.	
		Thermal	Input Power kW	0.23	0.36	0.52	0.55	1.10	
			Output Torque Nm	424.	699.	982.	1210.	2800.	
400.	1.81	Mechanical	Input Power kW	0.07	0.16	0.22	0.23	0.37	
			Output Torque Nm	142.	309.	501.	603.	950.	
		Thermal	Input Power kW	0.37	0.39	0.79	0.87	1.00	
			Output Torque Nm	832.	796.	1930.	2450.	2730.	
450.	1.61	Mechanical	Input Power kW	0.09	0.14	0.22	0.23	0.34	
			Output Torque Nm	189.	309.	501.	603.	950.	
		Thermal	Input Power kW	0.34	0.54	0.70	0.92	1.04	
			Output Torque Nm	786.	1310.	1750.	2630.	3110.	
500.	1.45	Mechanical	Input Power kW	0.09	0.14	0.19	0.21	0.33	
			Output Torque Nm	189.	309.	501.	603.	950.	
		Thermal	Input Power kW	0.37	0.39	0.71	0.87	1.00	
			Output Torque Nm	899.	940.	2030.	2760.	3080.	
600.	1.21	Mechanical	Input Power kW	0.08	0.12	0.17	0.1	8 0.29	
			Output Torque Nm	189.	309.	501.	603.	950.	
		Thermal	Input Power kW	0.36	0.39	0.66	0.87	1.00	
			Output Torque Nm	992.	1090.	2150.	3220.	3600.	
625.	1.16	Mechanical	Input Power kW	0.08	0.12	0.17	0.19	0.28	
			Output Torque Nm	189.	309.	501.	603.	950.	
		Thermal	Input Power kW	0.35	0.36	0.68	0.61	0.91	
			Output Torque Nm	982.	1030.	2200.	2140.	3290.	
700.	1.04	Mechanical	Input Power kW	0.05	0.05	0.12	0.12	0.20	
			Output Torque Nm	124.	119.	372.	405.	698.	
		Thermal	Input Power kW	0.17	0.19	0.37	0.29	0.41	
			Output Torque Nm	475.	522.	1260.	1070.	1520.	
750.	0.97	Mechanical	Input Power kW	0.07	0.10	0.16	0.17	0.25	
			Output Torque Nm	189.	309.	501.	603.	950.	
		Thermal	Input Power kW	0.35	0.36	0.68	0.61	0.91	
			Output Torque Nm	1110.	1190.	2500.	2500.	3840.	
800.	0.91	Mechanical	Input Power kW	0.05	0.11	0.15	0.15	0.22	
			Output Torque Nm	146.	309.	501.	603.	950.	
		Thermal	Input Power kW	0.27	0.28	0.56	0.50	0.78	
			Output Torque Nm	917.	871.	2150.	2210.	3660.	
			Efficiency %	26	27	32	38	42	

SERIES AJ

RATINGS AT 725 REV/MIN INPUT

	NOMINAL RATIO	NOMINAL OUTPUT SPEED REV / MIN	CAPACITY		SIZE OF UNIT				
					A0410	A0510	A0610	A0730	A0860
SINGLE REDUCTION	900.	0.81	Mechanical	Input Power kW	0.06	0.09	0.14	0.15	0.21
				Output Torque Nm	189.	309.	501.	603.	950.
			Thermal	Input Power kW	0.32	0.34	0.63	0.56	0.85
				Output Torque Nm	1190.	1270.	2610.	2610.	4190.
	1000.	0.73	Mechanical	Input Power kW	0.06	0.09	0.13	0.14	0.20
				Output Torque Nm	189.	309.	501.	603.	950.
			Thermal	Input Power kW	0.27	0.28	0.56	0.50	0.78
				Output Torque Nm	984.	1030.	2530.	2460.	4090.
	1200.	0.60	Mechanical	Input Power kW	0.06	0.08	0.12	0.12	0.17
				Output Torque Nm	189.	309.	501.	603.	950.
			Thermal	Input Power kW	0.27	0.28	0.56	0.50	0.78
				Output Torque Nm	1120.	1190.	2870.	2870.	4780.
	1250.	0.58	Mechanical	Input Power kW	0.05	0.08	0.11	0.12	0.18
				Output Torque Nm	189.	309.	501.	603.	950.
			Thermal	Input Power kW	0.23	0.24	0.49	0.41	0.57
				Output Torque Nm	1010.	1060.	2580.	2370.	3380.
	1400.	0.52	Mechanical	Input Power kW	0.04	0.05	0.11	0.11	0.16
				Output Torque Nm	152.	181.	501.	603.	950.
			Thermal	Input Power kW	0.17	0.19	0.37	0.29	0.41
				Output Torque Nm	793.	792.	2060.	1810.	2740.
	1500.	0.48	Mechanical	Input Power kW	0.05	0.07	0.10	0.11	0.16
				Output Torque Nm	189.	309.	501.	603.	950.
			Thermal	Input Power kW	0.23	0.24	0.49	0.41	0.57
				Output Torque Nm	1140.	1230.	2930.	2760.	3950.
	1600.	0.45	Mechanical	Input Power kW	0.04	0.06	0.09	0.10	0.15
				Output Torque Nm	147.	270.	445.	603.	950.
			Thermal	Input Power kW	0.27	0.28	0.56	0.50	0.78
				Output Torque Nm	1370.	1500.	3520.	3550.	5920.
1750.	0.41	Mechanical	Input Power kW	0.05	0.05	0.09	0.10	0.14	
			Output Torque Nm	189.	213.	501.	603.	950.	
		Thermal	Input Power kW	0.17	0.19	0.37	0.29	0.41	
			Output Torque Nm	846.	932.	2420.	2000.	3040.	
1800.	0.40	Mechanical	Input Power kW	0.05	0.07	0.10	0.10	0.14	
			Output Torque Nm	189.	309.	501.	603.	950.	
		Thermal	Input Power kW	0.21	0.21	0.41	0.34	0.50	
			Output Torque Nm	1080.	1170.	2620.	2400.	3910.	
2000.	0.36	Mechanical	Input Power kW	0.04	0.05	0.08	0.09	0.13	
			Output Torque Nm	149.	274.	452.	603.	950.	
		Thermal	Input Power kW	0.23	0.24	0.49	0.41	0.57	
			Output Torque Nm	1400.	1540.	3590.	3420.	4890.	
2100.	0.35	Mechanical	Input Power kW	0.04	0.05	0.09	0.09	0.13	
			Output Torque Nm	189.	247.	501.	603.	950.	
		Thermal	Input Power kW	0.17	0.19	0.37	0.29	0.41	
			Output Torque Nm	959.	1080.	2740.	2330.	3540.	
2400.	0.30	Mechanical	Input Power kW	0.04	0.05	0.08	0.09	0.12	
			Output Torque Nm	151.	277.	457.	603.	950.	
		Thermal	Input Power kW	0.21	0.21	0.41	0.34	0.50	
			Output Torque Nm	1330.	1470.	3210.	2960.	4840.	
2500.	0.29	Mechanical	Input Power kW	0.03	0.04	0.06	0.08	0.11	
			Output Torque Nm	107.	196.	326.	569.	891.	
		Thermal	Input Power kW	0.23	0.24	0.49	0.41	0.57	
			Output Torque Nm	1660.	1740.	4160.	4070.	5690.	
2800.	0.26	Mechanical	Input Power kW	0.03	0.05	0.07	0.08	0.11	
			Output Torque Nm	152.	279.	461.	603.	950.	
		Thermal	Input Power kW	0.17	0.19	0.37	0.29	0.41	
			Output Torque Nm	1180.	1360.	3360.	2880.	4380.	
3000.	0.24	Mechanical	Input Power kW	0.03	0.04	0.06	0.07	0.10	
			Output Torque Nm	109.	198.	330.	575.	900.	
		Thermal	Input Power kW	0.21	0.21	0.41	0.34	0.50	
			Output Torque Nm	1570.	1660.	3720.	3530.	5630.	
3500.	0.21	Mechanical	Input Power kW	0.03	0.04	0.05	0.07	0.09	
			Output Torque Nm	109.	200.	332.	580.	908.	
		Thermal	Input Power kW	0.17	0.19	0.37	0.29	0.41	
			Output Torque Nm	1390.	1540.	3880.	3430.	5090.	
3600.	0.20	Mechanical	Input Power kW	0.02	0.03	0.05	0.06	0.07	
			Output Torque Nm	83.	152.	252.	436.	680.	
		Thermal	Input Power kW	0.21	0.21	0.41	0.34	0.50	
			Output Torque Nm	1650.	1890.	4240.	3880.	6320.	
4200.	0.17	Mechanical	Input Power kW	0.02	0.03	0.04	0.05	0.07	
			Output Torque Nm	84.	154.	254.	440.	686.	
		Thermal	Input Power kW	0.17	0.19	0.37	0.29	0.41	
			Output Torque Nm	1460.	1750.	4430.	3770.	5720.	
			Efficiency %	7	10	11	15	18	

SERIES AJ

RATINGS AT 480 REV/MIN INPUT

	NOMINAL RATIO	NOMINAL OUTPUT SPEED REV / MIN	CAPACITY		SIZE OF UNIT					
					A0280	A0410	A0510	A0610	A0730	A0860
SINGLE REDUCTION	5.0	96.00	Mechanical	Input Power kW	0.34	0.78	1.71	2.57	3.65	6.35
				Output Torque Nm	30.	70.	144.	226.	345.	563.
			Thermal	Input Power kW	0.93	1.52	2.43	3.52	5.33	6.22
				Output Torque Nm	84.	138.	204.	310.	505.	551.
		Efficiency %	85	86	88	88	91	92		
	7.5	64.00	Mechanical	Input Power kW	0.30	0.68	1.17	1.81	2.73	4.17
				Output Torque Nm	37.	83.	146.	229.	355.	546.
			Thermal	Input Power kW	0.77	1.29	2.03	3.05	4.66	5.35
				Output Torque Nm	93.	158.	254.	386.	608.	701.
		Efficiency %	83	84	86	87	90	91		
	10.0	48.00	Mechanical	Input Power kW	0.27	0.66	1.17	1.59	2.23	3.63
				Output Torque Nm	44.	111.	200.	259.	404.	621.
			Thermal	Input Power kW	0.60	1.05	1.60	2.66	3.89	4.53
				Output Torque Nm	98.	177.	274.	434.	708.	776.
		Efficiency %	78	80	82	85	88	89		
	12.5	38.40	Mechanical	Input Power kW	0.25	0.61	1.03	1.63	2.39	3.17
				Output Torque Nm	45.	118.	204.	328.	511.	700.
			Thermal	Input Power kW	0.50	0.91	1.44	2.16	3.18	4.04
				Output Torque Nm	92.	176.	285.	437.	680.	895.
		Efficiency %	74	78	80	81	86	88		
	15.0	32.00	Mechanical	Input Power kW	0.22	0.59	0.80	1.39	2.13	3.24
				Output Torque Nm	47.	128.	182.	328.	520.	801.
			Thermal	Input Power kW	0.50	0.83	1.41	1.95	2.98	3.41
				Output Torque Nm	106.	183.	322.	461.	732.	842.
	Efficiency %	73	76	79	79	85	86			
20.0	24.00	Mechanical	Input Power kW	0.20	0.41	0.83	1.29	1.50	2.24	
			Output Torque Nm	49.	116.	231.	368.	476.	719.	
		Thermal	Input Power kW	0.33	0.78	0.96	1.39	2.53	2.8	
			Output Torque Nm	83.	225.	266.	399.	810.	927.	
	Efficiency %	63	74	70	72	82	83			
25.0	19.20	Mechanical	Input Power kW	0.17	0.44	0.73	1.13	1.61	2.32	
			Output Torque Nm	51.	143.	241.	387.	603.	882.	
		Thermal	Input Power kW	0.31	0.55	0.86	1.22	1.83	2.08	
			Output Torque Nm	92.	179.	284.	418.	688.	788.	
	Efficiency %	60	65	66	69	75	76			
30.0	16.00	Mechanical	Input Power kW	0.14	0.39	0.61	0.94	1.32	2.06	
			Output Torque Nm	49.	143.	233.	370.	581.	918.	
		Thermal	Input Power kW	0.29	0.51	0.82	1.12	1.70	1.94	
			Output Torque Nm	99.	190.	317.	439.	750.	865.	
	Efficiency %	57	62	64	66	74	75			
40.0	12.00	Mechanical	Input Power kW	0.09	0.26	0.45	0.69	0.94	1.49	
			Output Torque Nm	35.	120.	216.	335.	517.	838.	
		Thermal	Input Power kW	0.24	0.46	0.75	0.99	1.48	1.69	
			Output Torque Nm	95.	212.	367.	486.	821.	950.	
	Efficiency %	48	57	61	61	69	71			
50.0	9.60	Mechanical	Input Power kW	0.06	0.16	0.29	0.47	0.70	1.08	
			Output Torque Nm	28.	87.	158.	263.	459.	718.	
		Thermal	Input Power kW	0.21	0.37	0.55	0.79	1.12	1.23	
			Output Torque Nm	96.	201.	310.	451.	748.	820.	
	Efficiency %	45	53	55	57	66	67			
60.0	8.00	Mechanical	Input Power kW	0.04	0.12	0.20	0.31	0.48	0.73	
			Output Torque Nm	21.	66.	122.	202.	350.	545.	
		Thermal	Input Power kW	0.18	0.30	0.48	0.69	0.92	1.04	
			Output Torque Nm	89.	177.	311.	452.	693.	788.	
	Efficiency %	40	47	52	54	62	63			
70.0	6.86	Mechanical	Input Power kW	0.03	0.09	0.14	0.24	0.34	0.54	
			Output Torque Nm	17.	54.	95.	163.	274.	445.	
		Thermal	Input Power kW	0.15	0.26	0.40	0.55	0.73	0.82	
			Output Torque Nm	81.	174.	285.	392.	598.	682.	
	Efficiency %	36	45	49	50	57	59			

SERIES AJ

RATINGS AT 480 REV/MIN INPUT

	NOMINAL RATIO	NOMINAL OUTPUT SPEED REV / MIN	CAPACITY		SIZE OF UNIT				
					A0410	A0510	A0610	A0730	A0860
SINGLE REDUCTION	75.0	6.40	Mechanical	Input Power kW	0.21	0.29	0.50	0.58	0.98
				Output Torque Nm	189.	276.	492.	603.	950.
			Thermal	Input Power kW	0.54	0.98	1.25	1.48	1.83
				Output Torque Nm	494.	953.	1260.	1550.	1800.
	100.	4.80	Mechanical	Input Power kW	0.12	0.28	0.43	0.45	0.76
				Output Torque Nm	134.	309.	501.	603.	950.
			Thermal	Input Power kW	0.52	0.62	0.89	1.48	1.58
				Output Torque Nm	636.	709.	1050.	2010.	2000.
	125.	3.84	Mechanical	Input Power kW	0.15	0.23	0.37	0.40	0.66
				Output Torque Nm	189.	309.	501.	603.	950.
			Thermal	Input Power kW	0.37	0.56	0.79	1.14	1.16
				Output Torque Nm	485.	755.	1100.	1760.	1680.
	150.	3.20	Mechanical	Input Power kW	0.12	0.17	0.28	0.33	0.50
				Output Torque Nm	189.	284.	501.	603.	950.
			Thermal	Input Power kW	0.49	0.58	1.10	0.99	1.43
				Output Torque Nm	802.	997.	2020.	1900.	2790.
	200.	2.40	Mechanical	Input Power kW	0.07	0.16	0.24	0.26	0.39
				Output Torque Nm	140.	309.	501.	603.	950.
			Thermal	Input Power kW	0.48	0.57	0.78	0.99	1.43
				Output Torque Nm	1040.	1140.	1670.	2450.	3600.
	225.	2.13	Mechanical	Input Power kW	0.09	0.13	0.22	0.26	0.38
				Output Torque Nm	189.	283.	501.	603.	950.
			Thermal	Input Power kW	0.46	0.48	0.85	0.76	1.26
				Output Torque Nm	974.	1070.	2000.	1860.	3250.
	250.	1.92	Mechanical	Input Power kW	0.09	0.14	0.21	0.23	0.35
				Output Torque Nm	189.	309.	501.	603.	950.
			Thermal	Input Power kW	0.34	0.51	0.70	0.99	1.06
				Output Torque Nm	786.	1210.	1750.	2760.	3010.
300.	1.60	Mechanical	Input Power kW	0.08	0.11	0.17	0.20	0.32	
			Output Torque Nm	189.	283.	501.	603.	950.	
		Thermal	Input Power kW	0.31	0.32	0.81	0.72	0.85	
			Output Torque Nm	756.	823.	2490.	2310.	2610.	
350.	1.37	Mechanical	Input Power kW	0.07	0.11	0.17	0.18	0.17	
			Output Torque Nm	189.	309.	501.	603.	488.	
		Thermal	Input Power kW	0.33	0.48	0.6	0.76	0.50	
			Output Torque Nm	991.	1460.	2190.	2690.	1520.	
375.	1.28	Mechanical	Input Power kW	0.03	0.04	0.08	0.11	0.27	
			Output Torque Nm	60.	105.	179.	301.	950.	
		Thermal	Input Power kW	0.22	0.34	0.47	0.51	1.01	
			Output Torque Nm	588.	976.	1300.	1640.	3780.	
400.	1.20	Mechanical	Input Power kW	0.05	0.11	0.15	0.16	0.25	
			Output Torque Nm	144.	309.	501.	603.	950.	
		Thermal	Input Power kW	0.31	0.32	0.72	0.72	0.85	
			Output Torque Nm	995.	947.	2580.	2970.	3360.	
450.	1.07	Mechanical	Input Power kW	0.06	0.09	0.15	0.16	0.23	
			Output Torque Nm	189.	309.	501.	603.	950.	
		Thermal	Input Power kW	0.31	0.48	0.64	0.76	0.97	
			Output Torque Nm	1060.	1700.	2340.	3130.	4230.	
500.	0.96	Mechanical	Input Power kW	0.06	0.09	0.13	0.14	0.23	
			Output Torque Nm	189.	309.	501.	603.	950.	
		Thermal	Input Power kW	0.31	0.32	0.65	0.72	0.85	
			Output Torque Nm	1070.	1120.	2710.	3330.	3770.	
600.	0.80	Mechanical	Input Power kW	0.05	0.08	0.12	0.12	0.20	
			Output Torque Nm	189.	309.	501.	603.	950.	
		Thermal	Input Power kW	0.31	0.32	0.61	0.72	0.85	
			Output Torque Nm	1210.	1300.	2880.	3880.	4400.	
625.	0.77	Mechanical	Input Power kW	0.05	0.08	0.12	0.13	0.19	
			Output Torque Nm	189.	309.	501.	603.	950.	
		Thermal	Input Power kW	0.29	0.29	0.56	0.50	0.75	
			Output Torque Nm	1170.	1220.	2630.	2570.	3960.	
700.	0.69	Mechanical	Input Power kW	0.04	0.04	0.09	0.09	0.14	
			Output Torque Nm	127.	122.	382.	416.	716.	
		Thermal	Input Power kW	0.15	0.16	0.32	0.25	0.36	
			Output Torque Nm	592.	648.	1590.	1380.	1950.	
750.	0.64	Mechanical	Input Power kW	0.05	0.07	0.11	0.11	0.17	
			Output Torque Nm	189.	309.	501.	603.	950.	
		Thermal	Input Power kW	0.29	0.29	0.56	0.50	0.75	
			Output Torque Nm	1330.	1420.	2980.	2990.	4620.	
800.	0.60	Mechanical	Input Power kW	0.04	0.07	0.10	0.11	0.15	
			Output Torque Nm	151.	309.	501.	603.	950.	
		Thermal	Input Power kW	0.22	0.23	0.47	0.42	0.67	
			Output Torque Nm	1110.	1050.	2590.	2680.	4560.	
			Efficiency %	26	26	31	37	41	

SERIES AJ

RATINGS AT 480 REV/MIN INPUT

	NOMINAL RATIO	NOMINAL OUTPUT SPEED REV / MIN	CAPACITY		SIZE OF UNIT				
					A0410	A0510	A0610	A0730	A0860
SINGLE REDUCTION	900.	0.53	Mechanical	Input Power kW	0.04	0.06	0.09	0.10	0.15
				Output Torque Nm	189.	309.	501.	603.	950.
			Thermal	Input Power kW	0.27	0.28	0.52	0.47	0.73
				Output Torque Nm	1420.	1520.	3120.	3140.	5160.
	1000.	0.48	Mechanical	Input Power kW	0.04	0.06	0.09	0.10	0.14
				Output Torque Nm	189.	309.	501.	603.	950.
			Thermal	Input Power kW	0.22	0.23	0.47	0.42	0.67
				Output Torque Nm	1180.	1230.	3050.	2980.	5080.
	1200.	0.40	Mechanical	Input Power kW	0.04	0.06	0.08	0.08	0.12
				Output Torque Nm	189.	309.	501.	603.	950.
			Thermal	Input Power kW	0.22	0.23	0.47	0.42	0.67
				Output Torque Nm	1340.	1430.	3450.	3470.	5920.
	1250.	0.38	Mechanical	Input Power kW	0.04	0.05	0.08	0.08	0.12
				Output Torque Nm	189.	309.	501.	603.	950.
			Thermal	Input Power kW	0.19	0.20	0.41	0.36	0.50
				Output Torque Nm	1220.	1270.	3170.	2990.	4270.
	1400.	0.34	Mechanical	Input Power kW	0.03	0.04	0.07	0.08	0.11
				Output Torque Nm	156.	185.	501.	603.	950.
			Thermal	Input Power kW	0.15	0.16	0.32	0.25	0.36
				Output Torque Nm	986.	978.	2580.	2320.	3500.
	1500.	0.32	Mechanical	Input Power kW	0.03	0.05	0.07	0.07	0.11
				Output Torque Nm	189.	309.	501.	603.	950.
			Thermal	Input Power kW	0.19	0.20	0.41	0.36	0.50
				Output Torque Nm	1380.	1480.	3580.	3490.	4980.
	1600.	0.30	Mechanical	Input Power kW	0.03	0.04	0.06	0.07	0.10
				Output Torque Nm	151.	277.	457.	603.	950.
			Thermal	Input Power kW	0.22	0.23	0.47	0.42	0.67
				Output Torque Nm	1640.	1800.	4230.	4290.	7320.
	1750.	0.27	Mechanical	Input Power kW	0.03	0.04	0.06	0.07	0.10
				Output Torque Nm	189.	217.	501.	603.	950.
			Thermal	Input Power kW	0.15	0.16	0.32	0.25	0.36
				Output Torque Nm	1050.	1150.	3030.	2560.	3870.
	1800.	0.27	Mechanical	Input Power kW	0.03	0.05	0.07	0.07	0.09
				Output Torque Nm	189.	309.	501.	603.	950.
			Thermal	Input Power kW	0.17	0.18	0.34	0.29	0.43
				Output Torque Nm	1320.	1410.	3180.	3040.	4950.
2000.	0.24	Mechanical	Input Power kW	0.02	0.04	0.05	0.06	0.09	
			Output Torque Nm	153.	281.	463.	603.	950.	
		Thermal	Input Power kW	0.19	0.20	0.41	0.36	0.50	
			Output Torque Nm	1690.	1860.	4390.	4300.	6150.	
2100.	0.23	Mechanical	Input Power kW	0.03	0.04	0.06	0.06	0.09	
			Output Torque Nm	189.	253.	501.	603.	950.	
		Thermal	Input Power kW	0.15	0.16	0.32	0.25	0.36	
			Output Torque Nm	1190.	1340.	3420.	2980.	4510.	
2400.	0.20	Mechanical	Input Power kW	0.02	0.04	0.05	0.06	0.08	
			Output Torque Nm	154.	283.	467.	603.	950.	
		Thermal	Input Power kW	0.17	0.18	0.34	0.29	0.43	
			Output Torque Nm	1620.	1780.	3900.	3750.	6120.	
2500.	0.19	Mechanical	Input Power kW	0.02	0.03	0.04	0.05	0.08	
			Output Torque Nm	110.	201.	334.	582.	912.	
		Thermal	Input Power kW	0.19	0.20	0.41	0.36	0.50	
			Output Torque Nm	2010.	2100.	5080.	5120.	7150.	
2800.	0.17	Mechanical	Input Power kW	0.02	0.03	0.05	0.05	0.07	
			Output Torque Nm	156.	286.	471.	603.	950.	
		Thermal	Input Power kW	0.15	0.16	0.32	0.25	0.36	
			Output Torque Nm	1460.	1680.	4190.	3670.	5570.	
3000.	0.16	Mechanical	Input Power kW	0.02	0.03	0.04	0.05	0.07	
			Output Torque Nm	111.	203.	337.	588.	921.	
		Thermal	Input Power kW	0.17	0.18	0.34	0.29	0.43	
			Output Torque Nm	1910.	2000.	4510.	4460.	7110.	
3500.	0.14	Mechanical	Input Power kW	0.02	0.02	0.03	0.05	0.06	
			Output Torque Nm	112.	205.	340.	593.	928.	
		Thermal	Input Power kW	0.15	0.16	0.32	0.25	0.36	
			Output Torque Nm	1730.	1890.	4850.	4370.	6470.	
3600.	0.13	Mechanical	Input Power kW	0.02	0.02	0.03	0.04	0.05	
			Output Torque Nm	85.	156.	257.	446.	695.	
		Thermal	Input Power kW	0.17	0.18	0.34	0.29	0.43	
			Output Torque Nm	2000.	2290.	5150.	4900.	7980.	
4200.	0.11	Mechanical	Input Power kW	0.01	0.02	0.03	0.04	0.05	
			Output Torque Nm	85.	157.	259.	449.	700.	
		Thermal	Input Power kW	0.15	0.16	0.32	0.25	0.36	
			Output Torque Nm	1810.	2160.	5530.	4790.	7260.	
			Efficiency %	7	10	11	15	18	

SERIES AJ

RATINGS AT 250 REV/MIN INPUT

	NOMINAL RATIO	NOMINAL OUTPUT SPEED REV / MIN	CAPACITY		SIZE OF UNIT						
					A0280	A0410	A0510	A0610	A0730	A0860	
SINGLE REDUCTION	5.0	50.00	Mechanical	Input Power kW	0.20	0.51	0.93	1.36	2.39	3.31	
				Output Torque Nm	33.	86.	148.	225.	428.	554.	
			Thermal	Input Power kW	0.75	1.21	1.93	2.85	3.69	4.04	
				Output Torque Nm	127.	206.	306.	474.	662.	676.	
					Efficiency %	84	85	87	87	90	91
	7.5	33.33	Mechanical	Input Power kW	0.19	0.44	0.76	1.18	1.74	2.73	
				Output Torque Nm	43.	101.	179.	281.	429.	675.	
			Thermal	Input Power kW	0.62	1.03	1.63	2.50	3.26	3.51	
				Output Torque Nm	142.	239.	384.	595.	802.	868.	
					Efficiency %	81	82	84	85	89	89
	10.0	25.00	Mechanical	Input Power kW	0.16	0.36	0.71	1.03	1.21	2.36	
				Output Torque Nm	48.	114.	226.	316.	412.	762.	
			Thermal	Input Power kW	0.46	0.83	1.28	2.12	2.74	2.99	
				Output Torque Nm	142.	263.	412.	649.	940.	965.	
					Efficiency %	76	78	80	83	86	87
	12.5	20.00	Mechanical	Input Power kW	0.16	0.39	0.67	0.88	1.32	1.65	
				Output Torque Nm	54.	142.	246.	330.	529.	685.	
			Thermal	Input Power kW	0.38	0.70	1.15	1.67	2.25	2.69	
				Output Torque Nm	133.	253.	428.	632.	902.	1120.	
					Efficiency %	72	75	77	79	84	86
	15.0	16.67	Mechanical	Input Power kW	0.14	0.38	0.42	0.78	1.17	1.77	
				Output Torque Nm	56.	153.	177.	345.	534.	818.	
			Thermal	Input Power kW	0.39	0.63	1.15	1.51	2.12	2.27	
				Output Torque Nm	154.	260.	491.	665.	973.	1050.	
					Efficiency %	71	73	77	77	82	83
	20.0	12.50	Mechanical	Input Power kW	0.12	0.22	0.52	0.68	0.78	1.17	
				Output Torque Nm	57.	119.	264.	360.	462.	698.	
			Thermal	Input Power kW	0.26	0.61	0.74	1.07	1.81	1.94	
				Output Torque Nm	120.	329.	377.	569.	1080.	1160.	
					Efficiency %	60	71	67	69	80	80
	25.0	10.00	Mechanical	Input Power kW	0.10	0.27	0.46	0.68	0.87	1.36	
				Output Torque Nm	57.	161.	277.	429.	603.	950.	
			Thermal	Input Power kW	0.24	0.43	0.66	0.95	1.32	1.41	
				Output Torque Nm	133.	255.	401.	596.	914.	983.	
					Efficiency %	57	62	64	66	72	73
	30.0	8.33	Mechanical	Input Power kW	0.09	0.24	0.36	0.60	0.69	1.16	
				Output Torque Nm	57.	162.	252.	430.	556.	946.	
			Thermal	Input Power kW	0.23	0.40	0.64	0.87	1.23	1.32	
				Output Torque Nm	144.	271.	455.	628.	1000.	1080.	
					Efficiency %	54	59	61	63	70	71
	40.0	6.25	Mechanical	Input Power kW	0.05	0.15	0.23	0.43	0.49	0.86	
				Output Torque Nm	37.	126.	205.	379.	491.	878.	
Thermal			Input Power kW	0.19	0.36	0.60	0.78	1.08	1.16		
			Output Torque Nm	138.	304.	533.	699.	1100.	1190.		
				Efficiency %	46	54	58	58	66	67	
50.0	5.00	Mechanical	Input Power kW	0.04	0.09	0.17	0.27	0.37	0.59		
			Output Torque Nm	29.	91.	166.	276.	439.	707.		
		Thermal	Input Power kW	0.17	0.31	0.47	0.66	0.83	0.85		
			Output Torque Nm	144.	309.	476.	687.	1010.	1030.		
				Efficiency %	43	51	52	54	63	63	
60.0	4.17	Mechanical	Input Power kW	0.03	0.07	0.11	0.18	0.27	0.42		
			Output Torque Nm	22.	70.	128.	211.	366.	571.		
		Thermal	Input Power kW	0.15	0.26	0.41	0.60	0.69	0.73		
			Output Torque Nm	138.	273.	480.	713.	934.	998.		
				Efficiency %	38	44	49	51	58	59	
70.0	3.57	Mechanical	Input Power kW	0.02	0.05	0.08	0.14	0.20	0.31		
			Output Torque Nm	18.	57.	100.	170.	286.	465.		
		Thermal	Input Power kW	0.12	0.22	0.34	0.48	0.55	0.58		
			Output Torque Nm	125.	271.	443.	621.	809.	868.		
				Efficiency %	35	43	47	47	54	55	

SERIES AJ

RATINGS AT 250 REV/MIN INPUT

	NOMINAL RATIO	NOMINAL OUTPUT SPEED REV / MIN	CAPACITY		SIZE OF UNIT					
					A0410	A0510	A0610	A0730	A0860	
SINGLE REDUCTION	75.0	3.33	Mechanical	Input Power kW	0.11	0.16	0.27	0.32	0.53	
				Output Torque Nm	189.	284.	501.	603.	950.	
			Thermal	Input Power kW	0.46	0.81	1.06	1.17	1.60	
				Output Torque Nm	779.	1460.	1960.	2280.	2910.	
					Efficiency %	58	61	61	66	68
					Efficiency %	55	51	53	63	64
	100.	2.50	Mechanical	Input Power kW	0.06	0.15	0.24	0.25	0.41	
				Output Torque Nm	140.	309.	501.	603.	950.	
			Thermal	Input Power kW	0.45	0.53	0.75	1.17	1.39	
				Output Torque Nm	1010.	1100.	1630.	2940.	3250.	
					Efficiency %	55	51	53	63	64
					Efficiency %	47	48	50	55	57
	125.	2.00	Mechanical	Input Power kW	0.08	0.13	0.20	0.22	0.36	
				Output Torque Nm	189.	309.	501.	603.	950.	
			Thermal	Input Power kW	0.31	0.48	0.67	0.95	1.03	
				Output Torque Nm	763.	1180.	1710.	2690.	2710.	
					Efficiency %	47	48	50	55	57
					Efficiency %	47	48	50	55	57
	150.	1.67	Mechanical	Input Power kW	0.07	0.09	0.15	0.18	0.27	
				Output Torque Nm	189.	283.	501.	603.	950.	
			Thermal	Input Power kW	0.43	0.45	0.84	0.75	1.13	
				Output Torque Nm	1290.	1410.	2850.	2650.	4040.	
					Efficiency %	50	53	54	59	60
					Efficiency %	47	44	47	56	57
	200.	1.25	Mechanical	Input Power kW	0.04	0.09	0.13	0.14	0.21	
				Output Torque Nm	144.	309.	501.	603.	950.	
			Thermal	Input Power kW	0.43	0.45	0.68	0.75	1.13	
				Output Torque Nm	1690.	1630.	2640.	3410.	5200.	
			Efficiency %	47	44	47	56	57		
			Efficiency %	47	44	47	56	57		
225.	1.11	Mechanical	Input Power kW	0.05	0.07	0.12	0.14	0.21		
			Output Torque Nm	189.	282.	501.	603.	950.		
		Thermal	Input Power kW	0.36	0.37	0.65	0.58	1.02		
			Output Torque Nm	1400.	1520.	2780.	2620.	4820.		
				Efficiency %	46	50	50	54	57	
				Efficiency %	46	50	50	54	57	
250.	1.00	Mechanical	Input Power kW	0.05	0.07	0.11	0.12	0.19		
			Output Torque Nm	189.	309.	501.	603.	950.		
		Thermal	Input Power kW	0.30	0.45	0.60	0.75	0.92		
			Output Torque Nm	1260.	1920.	2780.	3820.	4740.		
				Efficiency %	40	42	44	48	50	
				Efficiency %	40	42	44	48	50	
300.	0.83	Mechanical	Input Power kW	0.05	0.06	0.09	0.11	0.18		
			Output Torque Nm	189.	281.	501.	603.	950.		
		Thermal	Input Power kW	0.24	0.25	0.62	0.56	0.65		
			Output Torque Nm	1070.	1160.	3500.	3280.	3630.		
				Efficiency %	38	41	48	52	49	
				Efficiency %	38	41	48	52	49	
350.	0.71	Mechanical	Input Power kW	0.04	0.06	0.09	0.10	0.10		
			Output Torque Nm	189.	309.	501.	603.	506.		
		Thermal	Input Power kW	0.29	0.37	0.60	0.58	0.45		
			Output Torque Nm	1610.	2060.	3510.	3760.	2480.		
				Efficiency %	37	39	40	44	40	
				Efficiency %	37	39	40	44	40	
375.	0.67	Mechanical	Input Power kW	0.02	0.02	0.04	0.06	0.15		
			Output Torque Nm	62.	109.	186.	313.	950.		
		Thermal	Input Power kW	0.20	0.32	0.41	0.48	0.8		
			Output Torque Nm	982.	1670.	2090.	2760.	5950.		
				Efficiency %	29	33	31	37	47	
				Efficiency %	29	33	31	37	47	
400.	0.63	Mechanical	Input Power kW	0.03	0.06	0.08	0.08	0.14		
			Output Torque Nm	150.	309.	501.	603.	950.		
		Thermal	Input Power kW	0.24	0.25	0.62	0.56	0.65		
			Output Torque Nm	1410.	1330.	4060.	4220.	4660.		
				Efficiency %	35	34	41	49	46	
				Efficiency %	35	34	41	49	46	
450.	0.56	Mechanical	Input Power kW	0.03	0.05	0.08	0.09	0.13		
			Output Torque Nm	189.	309.	501.	603.	950.		
		Thermal	Input Power kW	0.28	0.37	0.56	0.58	0.84		
			Output Torque Nm	1720.	2390.	3740.	4380.	6670.		
				Efficiency %	35	37	37	42	45	
				Efficiency %	35	37	37	42	45	
500.	0.50	Mechanical	Input Power kW	0.03	0.05	0.07	0.08	0.13		
			Output Torque Nm	189.	309.	501.	603.	950.		
		Thermal	Input Power kW	0.24	0.25	0.57	0.56	0.65		
			Output Torque Nm	1500.	1560.	4350.	4680.	5190.		
				Efficiency %	30	31	38	42	40	
				Efficiency %	30	31	38	42	40	
600.	0.42	Mechanical	Input Power kW	0.03	0.04	0.06	0.07	0.11		
			Output Torque Nm	189.	309.	501.	603.	950.		
		Thermal	Input Power kW	0.24	0.25	0.54	0.56	0.65		
			Output Torque Nm	1700.	1820.	4640.	5460.	6050.		
				Efficiency %	28	30	36	40	38	
				Efficiency %	28	30	36	40	38	
625.	0.40	Mechanical	Input Power kW	0.03	0.04	0.06	0.07	0.11		
			Output Torque Nm	189.	309.	501.	603.	950.		
		Thermal	Input Power kW	0.22	0.23	0.43	0.39	0.58		
			Output Torque Nm	1660.	1720.	3640.	3610.	5470.		
				Efficiency %	28	29	32	36	37	
				Efficiency %	28	29	32	36	37	
700.	0.36	Mechanical	Input Power kW	0.02	0.02	0.05	0.05	0.08		
			Output Torque Nm	132.	127.	396.	431.	741.		
		Thermal	Input Power kW	0.12	0.13	0.26	0.21	0.31		
			Output Torque Nm	921.	979.	2310.	2130.	3020.		
				Efficiency %	23	22	31	32	36	
				Efficiency %	23	22	31	32	36	
750.	0.33	Mechanical	Input Power kW	0.03	0.04	0.06	0.06	0.09		
			Output Torque Nm	189.	309.	501.	603.	950.		
		Thermal	Input Power kW	0.22	0.23	0.43	0.39	0.58		
			Output Torque Nm	1880.	2000.	4120.	4210.	6380.		
				Efficiency %	26	28	30	34	36	
				Efficiency %	26	28	30	34	36	
800.	0.31	Mechanical	Input Power kW	0.02	0.04	0.06	0.06	0.08		
			Output Torque Nm	157.	309.	501.	603.	950.		
		Thermal	Input Power kW	0.18	0.18	0.36	0.33	0.52		
			Output Torque Nm	1580.	1490.	3640.	3840.	6470.		
				Efficiency %	25	25	30	35	39	
				Efficiency %	25	25	30	35	39	

SERIES AJ

RATINGS AT 250 REV/MIN INPUT

NOMINAL RATIO	NOMINAL OUTPUT SPEED REV / MIN	CAPACITY		SIZE OF UNIT				
				A0410	A0510	A0610	A0730	A0860
900.	0.28	Mechanical	Input Power kW	0.02	0.03	0.05	0.06	0.08
			Output Torque Nm	189.	309.	501.	603.	950.
		Thermal	Input Power kW	0.21	0.22	0.40	0.36	0.56
			Output Torque Nm	2020.	2150.	4340.	4430.	7180.
1000.	0.25	Mechanical	Input Power kW	0.02	0.04	0.05	0.05	0.08
			Output Torque Nm	189.	309.	501.	603.	950.
		Thermal	Input Power kW	0.18	0.1	8 0.36	0.33	0.52
			Output Torque Nm	1680.	1750.	4280.	4230.	7150.
1200.	0.21	Mechanical	Input Power kW	0.02	0.03	0.04	0.05	0.07
			Output Torque Nm	189.	309.	501.	603.	950.
		Thermal	Input Power kW	0.18	0.1	8 0.36	0.33	0.52
			Output Torque Nm	1900.	2030.	4840.	4930.	8330.
1250.	0.20	Mechanical	Input Power kW	0.02	0.03	0.04	0.05	0.07
			Output Torque Nm	189.	309.	501.	603.	950.
		Thermal	Input Power kW	0.16	0.16	0.32	0.29	0.42
			Output Torque Nm	1760.	1840.	4500.	4360.	6470.
1400.	0.18	Mechanical	Input Power kW	0.02	0.02	0.04	0.04	0.06
			Output Torque Nm	162.	190.	501.	603.	950.
		Thermal	Input Power kW	0.12	0.13	0.26	0.21	0.31
			Output Torque Nm	1530.	1470.	3710.	3570.	5410.
1500.	0.17	Mechanical	Input Power kW	0.02	0.03	0.04	0.04	0.06
			Output Torque Nm	189.	309.	501.	603.	950.
		Thermal	Input Power kW	0.16	0.16	0.32	0.29	0.42
			Output Torque Nm	1990.	2140.	5080.	5080.	7540.
1600.	0.16	Mechanical	Input Power kW	0.02	0.02	0.03	0.04	0.05
			Output Torque Nm	157.	287.	474.	603.	950.
		Thermal	Input Power kW	0.18	0.1	8 0.36	0.33	0.52
			Output Torque Nm	2340.	2550.	5930.	6080.	10300.
1750.	0.14	Mechanical	Input Power kW	0.02	0.02	0.03	0.04	0.05
			Output Torque Nm	189.	224.	501.	603.	950.
		Thermal	Input Power kW	0.12	0.13	0.26	0.21	0.31
			Output Torque Nm	1620.	1730.	4350.	3920.	5940.
1800.	0.14	Mechanical	Input Power kW	0.02	0.02	0.04	0.04	0.05
			Output Torque Nm	189.	309.	501.	603.	950.
		Thermal	Input Power kW	0.14	0.15	0.28	0.24	0.37
			Output Torque Nm	1910.	2060.	4560.	4550.	7550.
2000.	0.13	Mechanical	Input Power kW	0.01	0.02	0.03	0.03	0.05
			Output Torque Nm	158.	291.	479.	603.	950.
		Thermal	Input Power kW	0.16	0.16	0.32	0.29	0.42
			Output Torque Nm	2440.	2690.	6220.	6260.	9300.
2100.	0.12	Mechanical	Input Power kW	0.02	0.02	0.03	0.03	0.05
			Output Torque Nm	189.	260.	501.	603.	950.
		Thermal	Input Power kW	0.12	0.13	0.26	0.21	0.31
			Output Torque Nm	1840.	2010.	4920.	4570.	6930.
2400.	0.10	Mechanical	Input Power kW	0.01	0.02	0.03	0.03	0.04
			Output Torque Nm	160.	293.	484.	603.	950.
		Thermal	Input Power kW	0.14	0.15	0.28	0.24	0.37
			Output Torque Nm	2340.	2580.	5590.	5600.	9300.
2500.	0.10	Mechanical	Input Power kW	0.01	0.01	0.02	0.03	0.04
			Output Torque Nm	114.	208.	345.	602.	943.
		Thermal	Input Power kW	0.16	0.16	0.32	0.29	0.42
			Output Torque Nm	2890.	3030.	7190.	7440.	10800.
2800.	0.09	Mechanical	Input Power kW	0.01	0.02	0.03	0.03	0.04
			Output Torque Nm	161.	295.	487.	603.	950.
		Thermal	Input Power kW	0.12	0.13	0.26	0.21	0.31
			Output Torque Nm	2250.	2520.	6020.	5620.	8540.
3000.	0.08	Mechanical	Input Power kW	0.01	0.01	0.02	0.03	0.04
			Output Torque Nm	115.	210.	348.	603.	950.
		Thermal	Input Power kW	0.14	0.15	0.28	0.24	0.37
			Output Torque Nm	2770.	2910.	6460.	6650.	10800.
3500.	0.07	Mechanical	Input Power kW	0.01	0.01	0.02	0.02	0.04
			Output Torque Nm	116.	211.	351.	603.	950.
		Thermal	Input Power kW	0.12	0.13	0.26	0.21	0.31
			Output Torque Nm	2670.	2840.	6960.	6680.	9910.
3600.	0.07	Mechanical	Input Power kW	0.01	0.01	0.02	0.02	0.03
			Output Torque Nm	87.	161.	265.	460.	717.
		Thermal	Input Power kW	0.14	0.15	0.28	0.24	0.37
			Output Torque Nm	2890.	3320.	7370.	7290.	12100.
4200.	0.06	Mechanical	Input Power kW	0.01	0.01	0.01	0.02	0.03
			Output Torque Nm	88.	162.	267.	463.	722.
		Thermal	Input Power kW	0.12	0.13	0.26	0.21	0.31
			Output Torque Nm	2790.	3240.	7940.	7320.	11100.
			Efficiency %	7	10	12	15	17

SINGLE REDUCTION

SERIES AJ

DIMENSIONS

SINGLE REDUCTION

A 0 0 0 0 W R

STANDARD UNIT

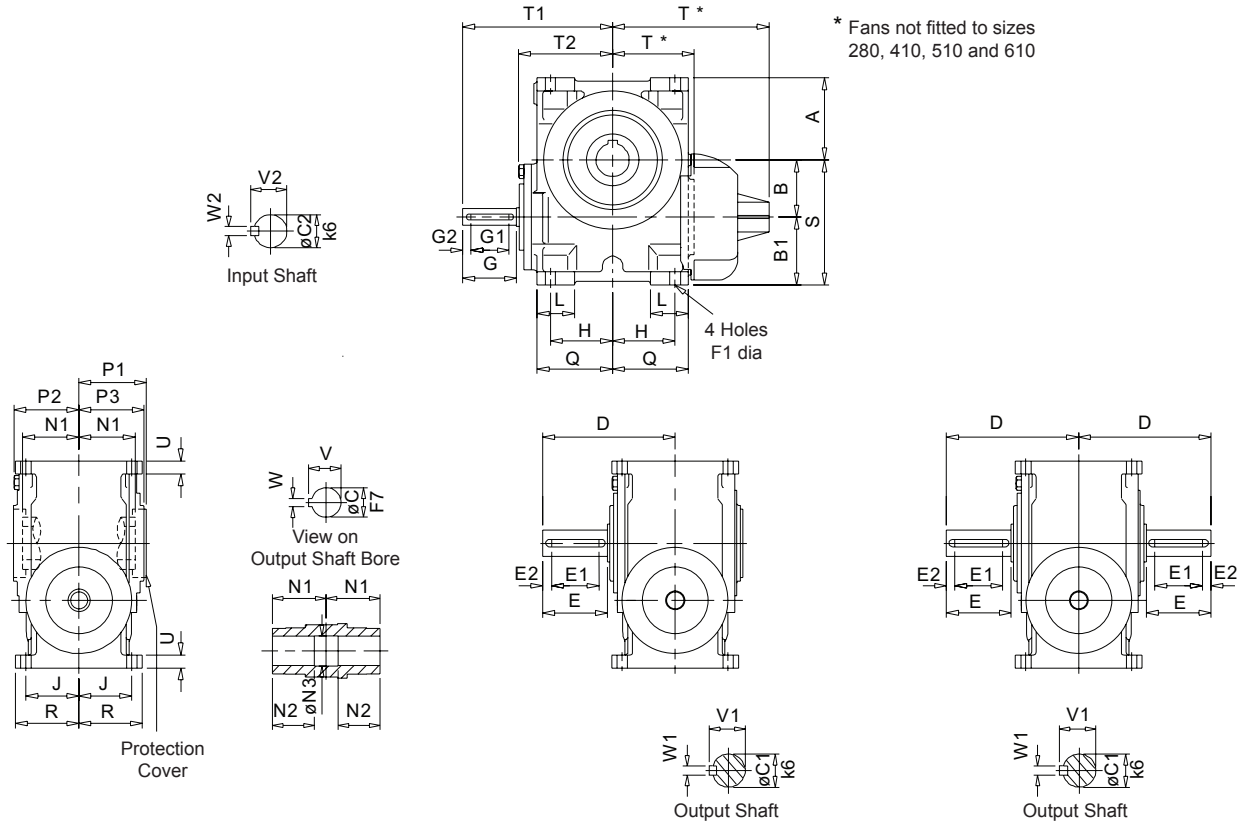

SIZE	A	B	B1	øC	øC1	C2	D	E	E1	E2	F1	G	G1	G2
A0280	58	28.6	52.4	16	16	10	79	35	23	5.5	9	29	22	3.5
A0410	66	41.3	59.7	22	20	16	98	45	34	6	11.5	41	31	6.5
A0510	74	50.8	61.2	25	25	16	117	57	42	7	11.5	48	35	6.5
A0610	87	60.3	71.7	35	28	18	140	70	55	7	11.5	57	44	7
A0730	105	73.0	80	40	30	22	168	83	62	7	13.5	70	57	7
A0860	117	85.7	92.3	50	35	25	200	98	80	8	17.5	83	62	9

SIZE	H	J	L	N1	N2	øN3	P1	P2	P3	Q	R	S	T	T1
A0280	52.5	41.5	30	40	32	16.2	48	45	44	61.5	50.5	81	53	90.5
A0410	58.5	49	32	50	40	22.2	58	55	55	69	60	101	62	109.5
A0510	57	52	35	56	45	25.2	63	61	61	67	62	112	75	133.4
A0610	66	56	40	64	50	35.2	79	67	69	80	67	132	86	158.8
A0730	81	70	45	77	60	40.2	95	81	84	95	84	153	197	190.5
A0860	90	79	55	93	73	50.2	104	97	99	108	97	178	227	219.1

SIZE	T2	U	V	V1	V2	W	W1	W2
A0280	61	9	18.4 18.3	18.00 17.87	11.200 11.075	5.015 4.985	5.000 4.970	3.000 2.375
A0410	68	10	24.9 24.8	22.50 22.37	18.000 17.870	6.015 5.985	6.000 5.970	5.000 4.970
A0510	86	12	28.5 28.3	28.00 27.71	18.000 17.870	8.018 7.982	8.000 7.964	5.000 4.970
A0610	100	14	38.5 38.3	31.00 30.71	20.500 20.370	10.018 9.982	8.000 7.964	6.000 5.970
A0730	122	16	43.5 43.3	33.00 32.71	24.500 24.370	12.021 11.979	8.000 7.964	6.000 5.970
A0860	132	18	54.0 53.8	38.00 37.71	28.000 27.710	14.021 13.979	10.000 9.964	8.000 7.964

SERIES AJ

DIMENSIONS

SINGLE REDUCTION

A 0 0 F R STANDARD UNIT FLANGE MOUNTED

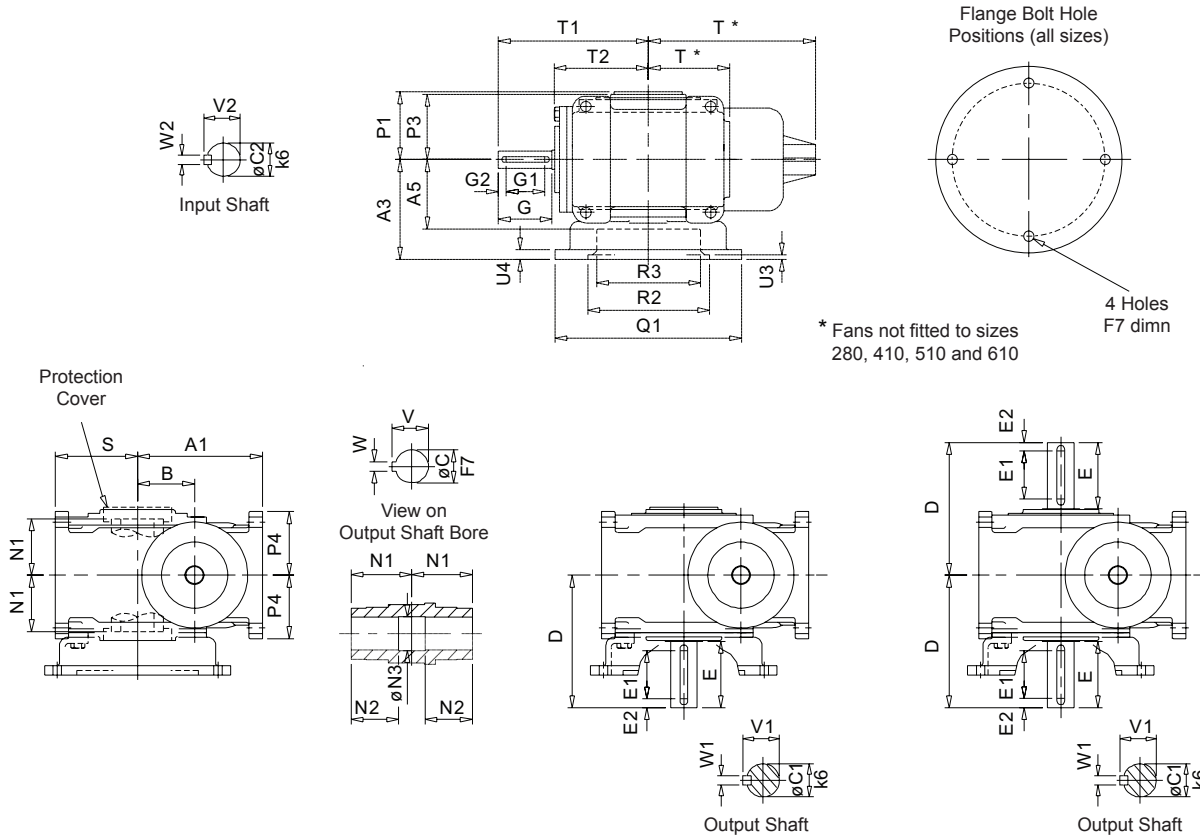

SIZE	A 1	A 3	A 5	B	øC	øC1	C2	D	E	E1	E2	F7	G
A0280	81	63	49	28.6	16	16	10	79	35	23	5.5	ø6.6 on 100 PCD	29
A0410	101	80	60	41.3	22	20	16	98	45	34	6	ø9 on 115 PCD	41
A0510	112	90	65	50.8	25	25	16	117	57	42	7	ø9 on 130 PCD	48
A0610	132	105	71	60.3	35	28	18	140	70	55	7	ø11 on 165 PCD	57
A0730	153	120	91	73.0	40	30	22	168	83	62	7	ø13.5 on 215 PCD	70
A0860	178	132	100	85.7	50	35	25	200	98	80	8	ø13.5 on 215 PCD	83

SIZE	G1	G2	N1	N2	øN3	P1	P3	P4	Q1	R2	R3	S	T	T1
A0280	22	3.5	40	32	16.2	48	44	50.5	120	80.030 80.000	60	58	53	90.5
A0410	31	6.5	50	40	22.2	58	55	60	140	95.035 95.000	72	66	62	109.5
A0510	35	6.5	56	45	25.2	63	61	62	160	110.035 110.000	88	74	75	133.4
A0610	44	7	64	50	35.2	79	69	67	200	130.040 130.000	110	87	86	158.8
A0730	57	7	77	60	40.2	95	84	84	250	180.040 180.000	136	105	197	190.5
A0860	62	9	93	73	50.2	104	99	97	250	180.040 180.000	150	117	227	219.1

SIZE	T2	U3	U4	V	V1	V2	W	W1	W2
A0280	61	3	7	18.4 18.3	18.00 17.87	11.200 11.075	5.015 4.985	5.000 4.970	3.000 2.375
A0410	68	3.5	8	24.9 24.8	22.50 22.37	18.000 17.870	6.015 5.985	6.000 5.970	5.000 4.970
A0510	86	4	9	28.5 28.3	28.00 27.71	18.000 17.870	8.018 7.982	8.000 7.964	5.000 4.970
A0610	100	4.5	10	38.5 38.3	31.00 30.71	20.500 20.370	10.018 9.982	8.000 7.964	6.000 5.970
A0730	122	5	12	43.5 43.3	33.00 32.71	24.500 24.370	12.021 11.979	8.000 7.964	6.000 5.970
A0860	132	5	12	54.0 53.8	38.00 37.71	28.000 27.710	14.021 13.979	10.000 9.964	8.000 7.964

SERIES AJ

DIMENSIONS

SINGLE REDUCTION

A 0 0 0 0 G R

STANDARD UNIT WITH SIDE MOUNTED FEET

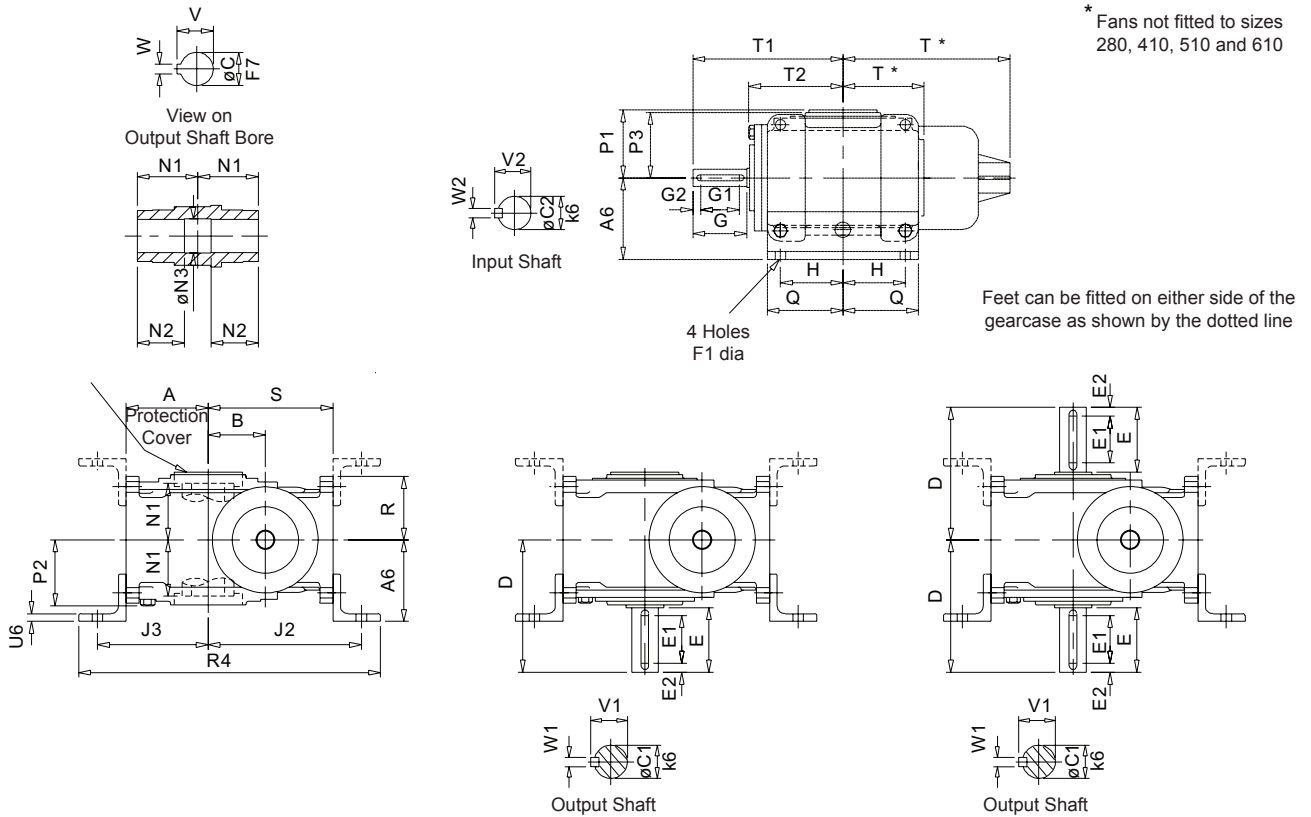

SIZE	A	A6	B	øC	øC1	C2	D	E	E1	E2	F1	G	G1	G2
A0280	58	62	28.6	16	16	10	79	35	23	5.5	9	29	22	3.5
A0410	66	75	41.3	22	20	16	98	45	34	6	11.5	41	31	6.5
A0510	74	78	50.8	25	25	16	117	57	42	7	11.5	48	35	6.5
A0610	87	86	60.3	35	28	18	140	70	55	7	11.5	57	44	7
A0730	105	103	73.0	40	30	22	168	83	62	7	13.5	70	57	7
A0860	117	118	85.7	50	35	25	200	98	80	8	17.5	83	62	9

SIZE	H	J2	J3	N1	N2	øN3	P1	P2	P3	R	R4	S	T	T1
A0280	52.5	101.5	78.5	40	32	16.2	48	45	44	50.5	199	81	53	90.5
A0410	58.5	127	92	50	40	22.2	58	55	55	60	247	101	62	109.5
A0510	57	138	100	56	45	25.2	63	61	61	62	266	112	75	133.4
A0610	66	162	117	64	50	35.2	79	67	69	67	319	132	86	158.8
A0730	81	186	138	77	60	40.2	95	81	84	84	358	153	197	190.5
A0860	90	217	156	93	73	50.2	104	97	99	97	415	178	227	219.1

SIZE	T2	U6	V	V1	V2	W	W1	W2
A0280	61	5	18.4 18.3	18.00 17.87	11.200 11.075	5.015 4.985	5.000 4.970	3.000 2.375
A0410	68	6	24.9 24.8	22.50 22.37	18.000 17.870	6.015 5.985	6.000 5.970	5.000 4.970
A0510	86	6	28.5 28.3	28.00 27.71	18.000 17.870	8.018 7.982	8.000 7.964	5.000 4.970
A0610	100	8	38.5 38.3	31.00 30.71	20.500 20.370	10.018 9.982	8.000 7.964	6.000 5.970
A0730	122	8	43.5 43.3	33.00 32.71	24.500 24.370	12.021 11.979	8.000 7.964	6.000 5.970
A0860	132	10	54.0 53.8	38.00 37.71	28.000 27.710	14.021 13.979	10.000 9.964	8.000 7.964

SERIES AJ

DIMENSIONS

SINGLE REDUCTION

A 0 0 0 H R

STANDARD UNIT WITH END MOUNTED FEET

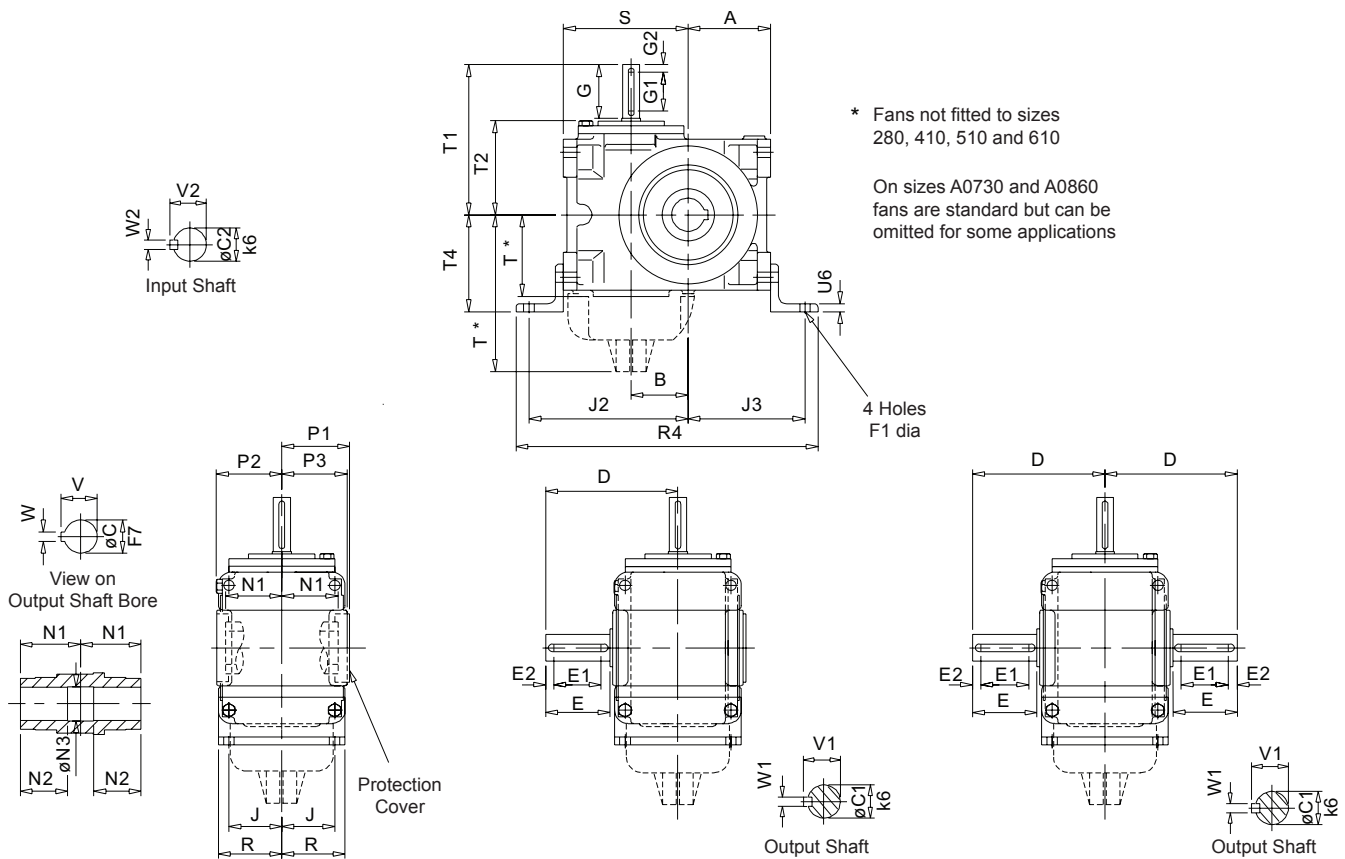

SIZE	A	B	ϕC	$\phi C1$	C2	D	E	E1	E2	F1	G	G1	G2	J
A0280	58	28.6	16	16	10	79	35	23	5.5	9	29	22	3.5	41.5
A0410	66	41.3	22	20	16	98	45	34	6	11.5	41	31	6.5	49
A0510	74	50.8	25	25	16	117	57	42	7	11.5	48	35	6.5	52
A0610	87	60.3	35	28	18	140	70	55	7	11.5	57	44	7	56
A0730	105	73.0	40	30	22	168	83	62	7	13.5	70	57	7	70
A0860	117	85.7	50	35	25	200	98	80	8	17.5	83	62	9	79

SIZE	J2	J3	N1	N2	$\phi N3$	P1	P2	P3	R	R4	S	T	T1	T2
A0280	101.5	78.5	40	32	16.2	48	45	44	50.5	199	81	53	90.5	61
A0410	127	92	50	40	22.2	58	55	55	60	247	101	62	109.5	68
A0510	138	100	56	45	25.2	63	61	61	62	266	112	75	133.4	86
A0610	162	117	64	50	35.2	79	67	69	67	319	132	86	158.8	100
A0730	186	138	77	60	40.2	95	81	84	84	358	153	197	190.5	122
A0860	217	156	93	73	50.2	104	97	99	97	415	178	227	219.1	132

SIZE	T4	U6	V	V1	V2	W	W1	W2
A0280	73	5	18.4	18.00	11.200	5.015	5.000	3.000
			18.3	17.87	11.075	4.985	4.970	2.375
A0410	84.5	6	24.9	22.50	18.000	6.015	6.000	5.000
			24.8	22.37	17.870	5.985	5.970	4.970
A0510	83	6	28.5	28.00	18.000	8.018	8.000	5.000
			28.3	27.71	17.870	7.982	7.964	4.970
A0610	96	8	38.5	31.00	20.500	10.018	8.000	6.000
			38.3	30.71	20.370	9.982	7.964	5.970
A0730	114	8	43.5	33.00	24.500	12.021	8.000	6.000
			43.3	32.71	24.370	11.979	7.964	5.970
A0860	129	10	54.0	38.00	28.000	14.021	10.000	8.000
			53.8	37.71	27.710	13.979	9.964	7.964

SERIES AJ

DIMENSIONS

DOUBLE REDUCTION

A 0 0 W D STANDARD UNIT

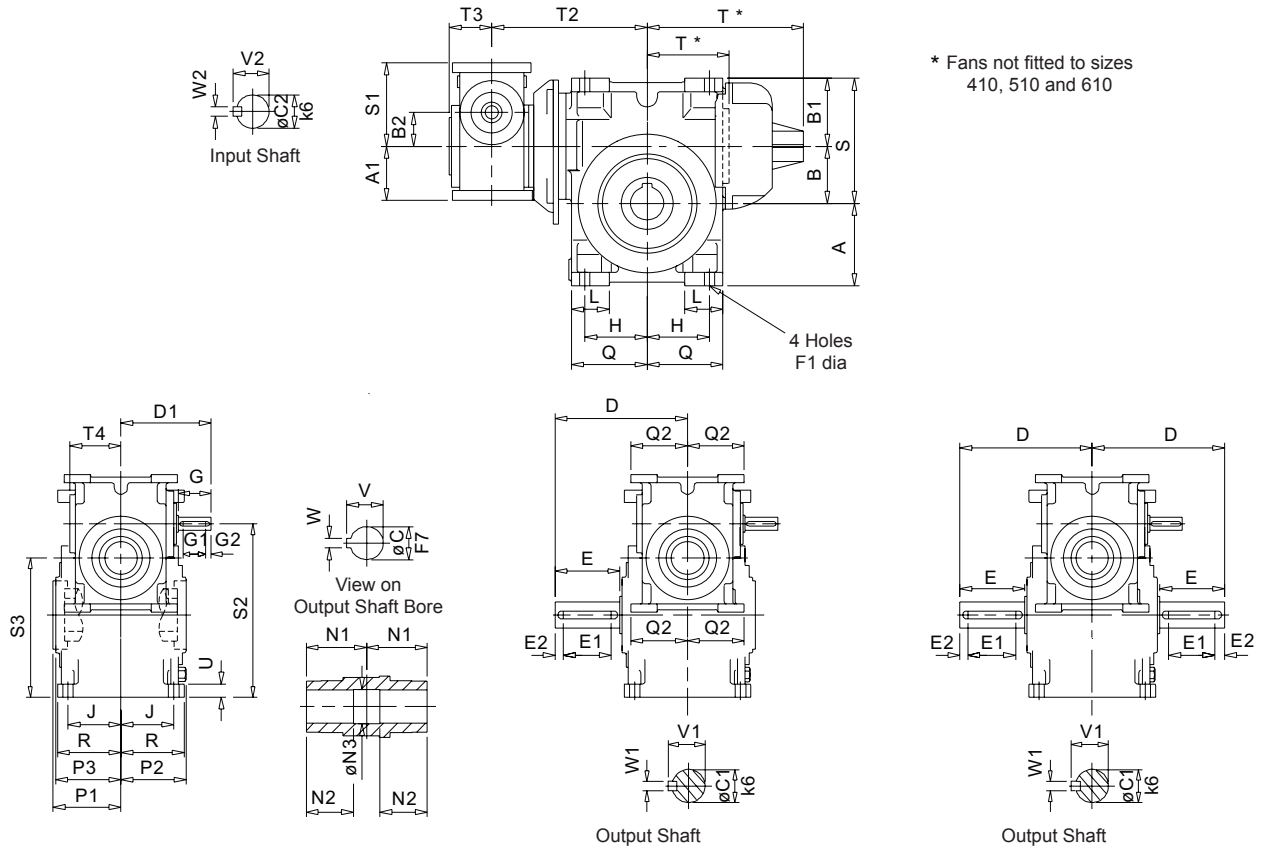

SIZE	A	A6	B	B1	B2	øC	øC1	C2	D	D1	E	E1	E2	F1	G
A0410	66	58	41.3	59.7	28.6	22	20	10	98	90.5	45	34	6	11.5	29
A0510	74	58	50.8	61.2	28.6	25	25	10	117	90.5	57	42	7	11.5	29
A0610	87	66	60.3	71.7	41.3	35	28	16	140	109.5	70	55	7	11.5	41
A0730	105	66	73.0	80	41.3	40	30	16	168	109.5	83	62	7	13.5	41
A0860	117	74	85.7	92.3	50.8	50	35	16	200	133.4	98	80	8	17.5	48

SIZE	G1	G2	H	J	L	N1	N2	øN3	P1	P2	P3	Q	Q2	R	S
A0410	22	3.5	58.5	49	32	50	40	22.2	58	55	55	69	61.5	60	101
A0510	22	3.5	57	52	35	56	45	25.2	63	61	61	67	61.5	62	112
A0610	31	6.5	66	56	40	64	50	35.2	79	67	69	80	69	67	132
A0730	31	6.5	81	70	45	77	60	40.2	95	81	84	95	69	81	153
A0860	35	6.5	90	79	55	93	73	50.2	104	97	99	108	67	97	178

SIZE	S1	S2	S3	T	T2	T3	T4	U	V	V1	V2	W	W1	W2
A0410	81	135.9	107.3	62	126	48	53	10	24.9 24.8	22.50 22.37	11.200 11.075	6.015 5.985	6.000 5.970	3.000 2.375
A0510	81	153.4	124.8	75	143	48	53	12	28.5 28.3	28.00 27.71	11.200 11.075	8.018 7.982	8.000 7.964	3.000 2.375
A0610	101	188.6	147.3	86	171	58	62	14	38.5 38.3	31.00 30.71	18.000 17.870	10.018 9.982	8.000 7.964	5.000 4.970
A0730	101	219.6	178	197	192	58	62	16	43.5 43.3	33.00 32.71	18.000 17.870	12.021 11.979	8.000 7.964	5.000 4.970
A0860	112	253.5	202.7	227	208	63	75	18	54.0 53.8	38.00 37.71	18.000 17.870	14.021 13.979	10.000 9.964	5.000 4.970

SERIES AJ

DIMENSIONS

DOUBLE REDUCTION

A 0 0 F D

STANDARD UNIT FLANGE MOUNTED

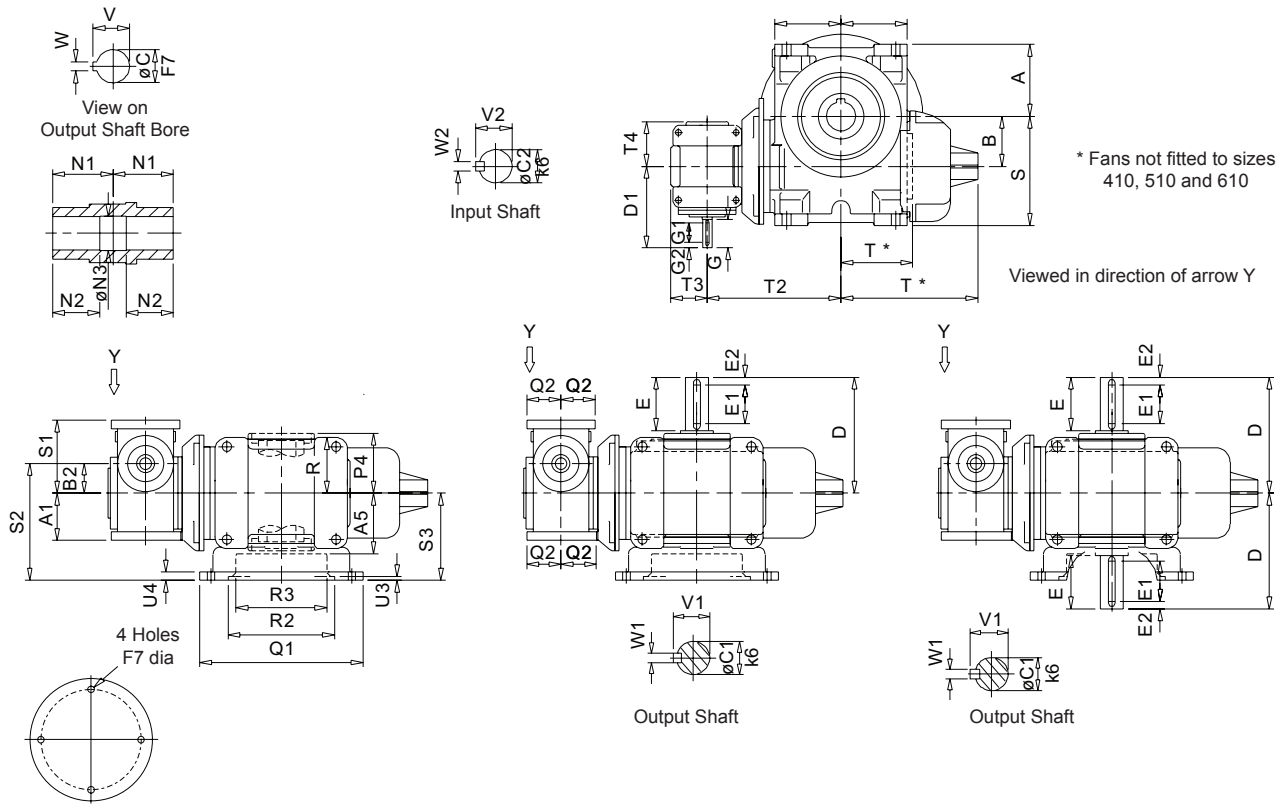

Flange Bolt Hole Positions
(all sizes)

SIZE	A	A1	A5	B	B2	ØC	ØC1	C2	D	D1	E	E1	E2	F7
A0410	66	58	60	41.3	28.6	22	20	10	98	90.5	45	34	6	Ø9 on 115 PCD
A0510	74	58	65	50.8	28.6	25	25	10	117	90.5	57	42	7	Ø9 on 130 PCD
A0610	87	66	71	60.3	41.3	35	28	16	140	109.5	70	55	7	Ø11 on 165 PCD
A0730	105	66	91	73	41.3	40	30	16	168	109.5	83	62	7	Ø13.5 on 215 PCD
A0860	117	74	100	85.7	50.8	50	35	16	200	133.4	98	80	8	Ø13.5 on 215 PCD

SIZE	G	G1	G2	N1	N2	ØN3	P4	Q	Q1	Q2	R2	R3	S	S1	S2
A0410	29	22	3.5	50	40	22.2	55	69	140	61.5	95.035 95.000	72	101	81	108.6
A0510	29	22	3.5	56	45	25.2	61	67	160	61.5	110.035 110.000	88	112	81	118.6
A0610	41	31	6.5	64	50	35.2	69	80	200	69	130.040 130.000	110	132	101	146.3
A0730	41	31	6.5	77	60	40.2	84	95	250	69	180.040 180.000	136	153	101	161.3
A0860	48	35	6.5	93	73	50.2	99	108	250	67	180.040 180.000	150	178	112	182.8

SIZE	S3	T	T2	T3	T4	U3	U4	V	V1	V2	W	W1	W2
A0410	80	62	126	48	53	3.5	8	24.9 24.8	22.50 22.37	11.200 11.075	6.015 5.985	6.000 5.970	3.000 2.375
A0510	90	75	143	48	53	4	9	28.5 28.3	28.00 27.71	11.200 11.075	8.018 7.982	8.000 7.964	3.000 2.375
A0610	105	86	171	58	62	4.5	10	38.5 38.3	31.00 30.71	18.000 17.870	10.018 9.982	8.000 7.964	5.000 4.970
A0730	120	197	192	58	62	5	12	43.5 43.3	33.00 32.71	18.000 17.870	12.021 11.979	8.000 7.964	5.000 4.970
A0860	132	227	208	63	75	5	12	54.0 53.8	38.00 37.71	18.000 17.870	14.021 13.979	10.000 9.964	5.000 4.970

SERIES AJ

DIMENSIONS

DOUBLE REDUCTION

A 0 0 0 0 G D

STANDARD UNIT WITH SIDE MOUNTED FEET

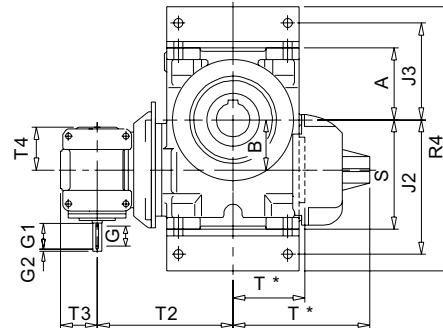
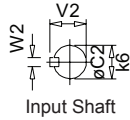
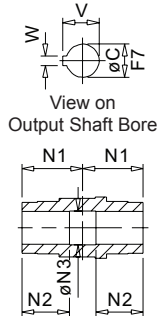

* Fans not fitted to sizes 410, 510 and 610

Viewed in direction of arrow Y

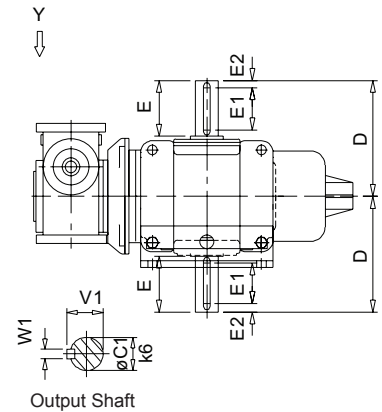
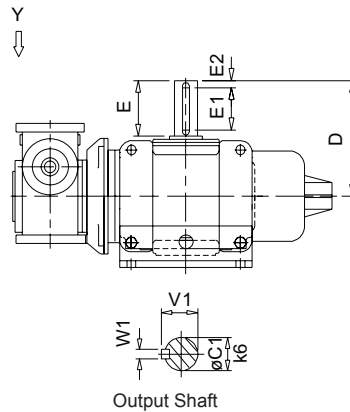
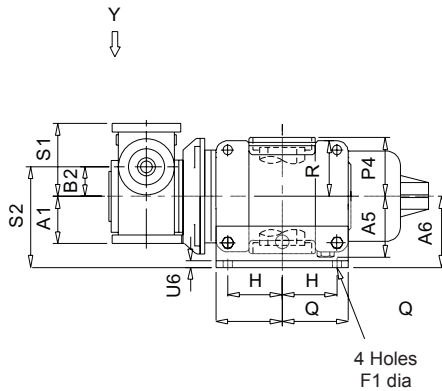

SIZE	A	A1	A5	A6	B	B2	øC	øC1	C2	D	D1	E	E1	E2	F1
A0410	66	58	55	75	41.3	28.6	22	20	10	98	90.5	45	34	6	11.5
A0510	74	58	61	78	50.8	28.6	25	25	10	117	90.5	57	42	7	11.5
A0610	87	66	67	86	60.3	41.3	35	28	16	140	109.5	70	55	7	11.5
A0730	105	66	81	103	73.0	41.3	40	30	16	168	109.5	83	62	7	13.5
A0860	117	74	97	118	85.7	50.8	50	35	16	200	133.4	98	80	8	17.5

SIZE	G	G1	G2	H	J2	J3	L	N1	N2	øN3	Q	R	S	S1	S2
A0410	29	22	3.5	58.5	127	92	50	40	22.2	55	69	60	101	81	103.6
A0510	29	22	3.5	57	138	100	56	45	25.2	61	67	62	112	81	106.6
A0610	41	31	6.5	66	162	117	64	50	35.2	69	80	67	132	101	127.3
A0730	41	31	6.5	81	186	138	77	60	40.2	84	95	81	153	101	144.3
A0860	48	35	6.5	90	217	156	93	73	50.2	99	108	97	178	112	168.8

SIZE	T	T2	T3	T4	U6	V	V1	V2	W	W1	W2
A0410	62	126	48	53	6	24.9 24.8	22.50 22.37	11.200 11.075	6.015 5.985	6.000 5.970	3.000 2.375
A0510	75	143	48	53	6	28.5 28.3	28.00 27.71	11.200 11.075	8.018 7.982	8.000 7.964	3.000 2.375
A0610	86	171	58	62	8	38.5 38.3	31.00 30.71	18.000 17.870	10.018 9.982	8.000 7.964	5.000 4.970
A0730	197	192	58	62	8	43.5 43.3	33.00 32.71	18.000 17.870	12.021 11.979	8.000 7.964	5.000 4.970
A0860	227	208	63	75	10	54.0 53.8	38.00 37.71	18.000 17.870	14.021 13.979	10.000 9.964	5.000 4.970

SERIES AJ

CASE WITH ADDITIONAL MACHINED SPIGOT

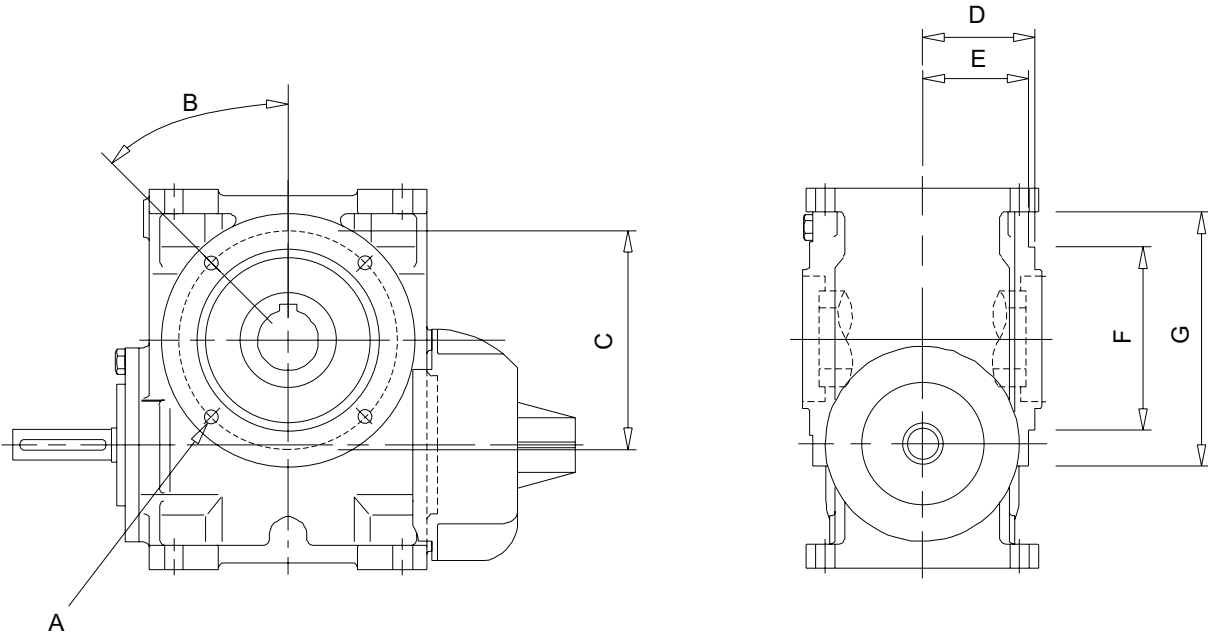

UNIT SIZE	A	B	C	D	E	F	G
A0280	4 Holes equally spaced M6 x 9 Deep	45o	73 PCD	44	41	52.99 52.97	85
A0410	4 Holes equally spaced M6 x 12 Deep	45o	88.9 PCD	55	51	69.99 69.97	101
A0510	4 Holes equally spaced M8 x 14 Deep	45o	107 PCD	59	55	84.99 84.97	122
A0610	8 Holes equally spaced M8 x 14 Deep	22.5o	130 PCD	65	61	104.99 104.97	146
A0730	8 Holes equally spaced M10 x 18 Deep	22.5o	155 PCD	79	74	124.99 124.97	175
A0860	8 Holes equally spaced M10 x 18 Deep	22.5o	176 PCD	95	90	144.99 144.97	196

This option is available in Additional Features - Column 20

TORQUE ARM DETAILS

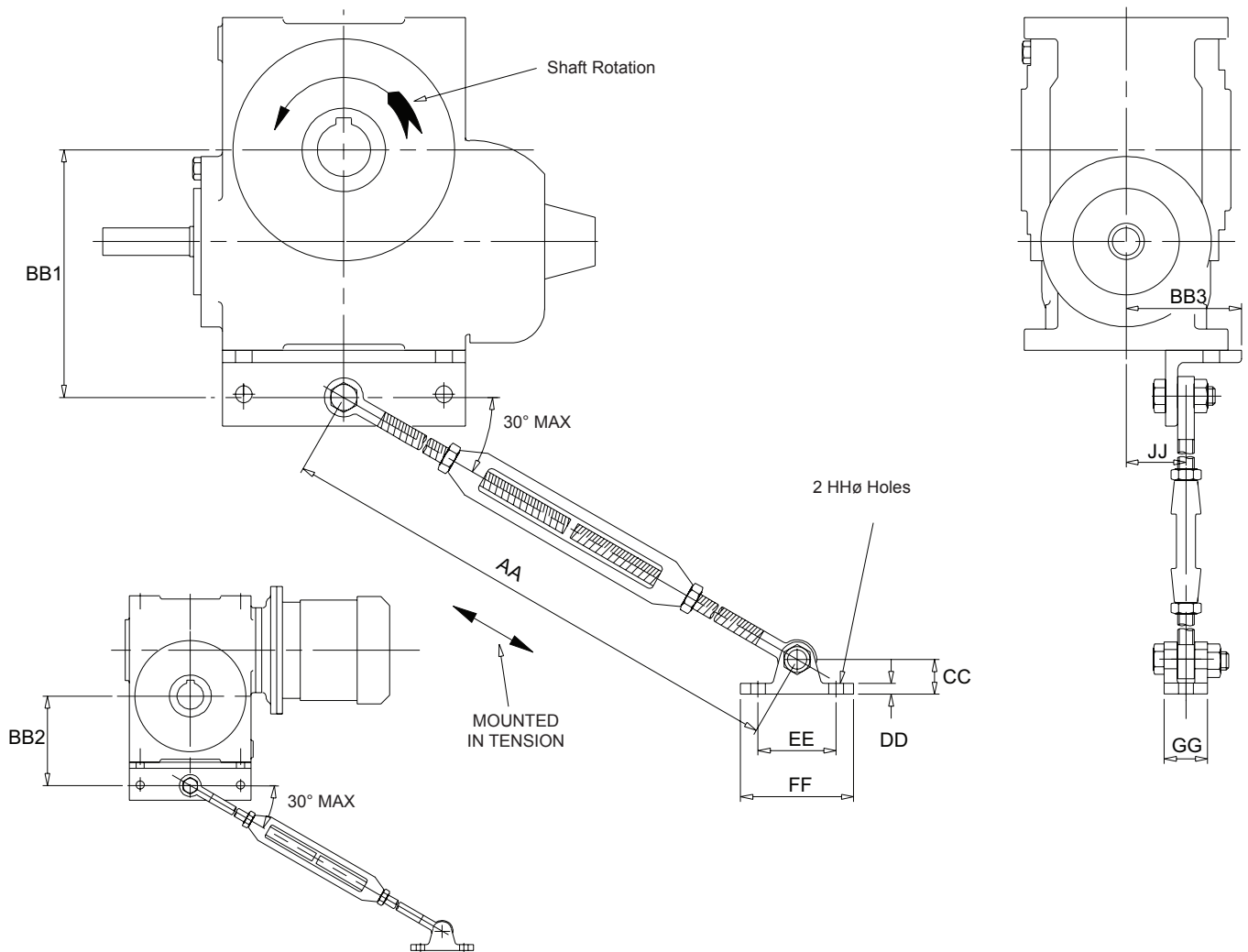

	SIZE OF UNIT					
	A0280	A0410	A0510	A0610	A0730	A0860
BB1	100	126	137	163	184	215
BB2	77	91	99	118	136	154
BB3	51	63	66	76	87	100
AA	355 - 510	355 - 510	480 - 635	480 - 635	480 - 635	610 - 750
CC	21	21	25	25	25	30
DD	6	6	8	8	8	10
EE	51	51	57	57	57	70
FF	70	70	83	83	83	102
GG	25	25	30	30	30	38
HH	9	9	11	11	11	14.3
JJ	31	34	38	40	51	58

The torque arm should be fitted on that side of the gear unit which is adjacent to the driven machine.

The angle between the torque arm and the high speed shaft MUST NOT EXCEED 30°. The torque arm must be positioned so that it is loaded IN TENSION, i.e. in the direction of TORQUE REACTION, which is opposite to the direction of shaft rotation, as shown above.

For reversing applications two torque arms must be fitted in opposite mounting positions.

Gear units must be locked axially when mounted in position, and supported by the low speed sleeve for a minimum of 90% of the bore length.

SHIPPING SPECIFICATION

SINGLE REDUCTION

COLUMN 10 ENTRY		UNIT SIZE					
		A0280	A0410	A0510	A0610	A0730	A0860
R	Unit Weight	4.5	7.4	11.2	16	29	45
	Weight Packed	6.0	9.0	13.2	19	34	53
	Volume Packed (m3)	0.013	0.016	0.018	0.028	0.056	0.088
G	Unit Weight	7.0	11.3	15.3	22	35	54
	Weight Packed	9.0	13	18	26	42	64
	Volume Packed (m3)	0.015	0.021	0.03	0.04	0.07	0.10

DOUBLE REDUCTION

COLUMN 10 ENTRY		UNIT SIZE				
		A0410	A0510	A0610	A0730	A0860
D	Unit Weight	12.5	16.5	25	38	59
	Weight Packed	15.5	18.5	28	43	65
	Volume Packed (m3)	0.029	0.031	0.044	0.072	0.106
H	Unit Weight	15.5	19	29	42	63
	Weight Packed	19	22	37	49	70
	Volume Packed (m3)	0.031	0.033	0.049	0.077	0.118

ALL WEIGHTS IN KG

ALL WEIGHTS INCLUDE LUBRICANT

- COLUMN 10 ENTRY
- R** - REDUCER UNIT - SINGLE REDUCTION
 - G** - UNIT TO ALLOW FITTING OF A NON STANDARD IEC MOTOR - SINGLE REDUCTION
 - D** - REDUCER UNIT - DOUBLE REDUCTION
 - H** - UNIT TO ALLOW FITTING OF A NON STANDARD IEC MOTOR - DOUBLE REDUCTION
- G** AND **H** TYPE UNIT WEIGHTS AND VOLUMES DO NOT INCLUDE MOTORS

MAXIMUM STANDARD MOTOR FLANGES HAVE BEEN INCLUDED IN WEIGHTS AND VOLUMES

IMPORTANT

Product Safety Information

General - The following information is important in ensuring safety. It **must** be brought to the attention of personnel involved in the selection of the equipment, those responsible for the design of the machinery in which it is to be incorporated and those involved in its installation, use and maintenance.

The equipment will operate safely provided it is selected, installed, used and maintained properly. As with any power transmission equipment **proper precautions must** be taken as indicated in the following paragraphs, to ensure safety.

Potential Hazards - these are **not** necessarily listed in any order of severity as the degree of danger varies in individual circumstances. It is important therefore that the list is studied in its entirety:-

- 1) Fire/Explosion
 - (a) Oil mists and vapour are generated within gear units. It is therefore dangerous to use naked lights in the proximity of gearbox openings, due to the risk of fire or explosion.
 - (b) In the event of fire or serious overheating (over 300 °C), certain materials (rubber, plastics, etc.) may decompose and produce fumes. Care should be taken to avoid exposure to the fumes, and the remains of burned or overheated plastic/rubber materials should be handled with rubber gloves.
- 2) Guards - Rotating shafts and couplings must be guarded to eliminate the possibility of physical contact or entanglement of clothing. It should be of rigid construction and firmly secured.
- 3) Noise - High speed gearboxes and gearbox driven machinery may produce noise levels which are damaging to the hearing with prolonged exposure. Ear defenders should be provided for personnel in these circumstances. Reference should be made to the Department of Employment Code of Practice for reducing exposure of employed persons to noise.
- 4) Lifting - Where provided (on larger units) only the lifting points or eyebolts must be used for lifting operations (see maintenance manual or general arrangement drawing for lifting point positions). Failure to use the lifting points provided may result in personal injury and/or damage to the product or surrounding equipment. Keep clear of raised equipment.
- 5) Lubricants and Lubrication
 - (a) Prolonged contact with lubricants can be detrimental to the skin. The manufacturer's instruction must be followed when handling lubricants.
 - (b) The lubrication status of the equipment must be checked before commissioning. Read and carry out all instructions on the lubricant plate and in the installation and maintenance literature. Heed all warning tags. Failure to do so could result in mechanical damage and in extreme cases risk of injury to personnel.
- 6) Electrical Equipment - Observe hazard warnings on electrical equipment and isolate power before working on the gearbox or associated equipment, in order to prevent the machinery being started.
- 7) Installation, Maintenance and Storage
 - (a) In the event that equipment is to be held in storage, for a period exceeding 6 months, prior to installation or commissioning, application engineering must be consulted regarding special preservation requirements. Unless otherwise agreed, equipment must be stored in a building protected from extremes of temperature and humidity to prevent deterioration.
The rotating components (gears and shafts) must be turned a few revolutions once a month (to prevent bearings brinelling).
 - (b) External gearbox components may be supplied with preservative materials applied, in the form of a "waxed" tape overwrap or wax film preservative. Gloves should be worn when removing these materials. The former can be removed manually, the latter using white spirit as a solvent.
Preservatives applied to the internal parts of the gear units do not require removal prior to operation.
 - (c) Installation must be performed in accordance with the manufacturer's instructions and be undertaken by suitably qualified personnel.
 - (d) Before working on a gearbox or associated equipment, ensure that the load has been removed from the system to eliminate the possibility of any movement of the machinery and isolate power supply. Where necessary, provide mechanical means to ensure the machinery cannot move or rotate. Ensure removal of such devices after work is complete.
 - (e) Ensure the proper maintenance of gearboxes in operation. Use only the correct tools and approved spare parts for repair and maintenance. Consult the Maintenance Manual before dismantling or performing maintenance work.
- 8) Hot Surfaces and Lubricants
 - (a) During operation, gear units may become sufficiently hot to cause skin burns. Care must be taken to avoid accidental contact.
 - (b) After extended running the lubricant in gear units and lubrication systems may reach temperatures sufficient to cause burns. Allow equipment to cool before servicing or performing adjustments.
- 9) Selection and Design
 - (a) Where gear units provide a backstop facility, ensure that back-up systems are provided if failure of the backstop device would endanger personnel or result in damage.
 - (b) The driving and driven equipment must be correctly selected to ensure that the complete machinery installation will perform satisfactorily, avoiding system critical speeds, system torsional vibration, etc.
 - (c) The equipment must not be operated in an environment or at speeds, powers, torques or with external loads beyond those for which it was designed.
 - (d) As improvements in design are being made continually the contents of this catalogue are not to be regarded as binding in detail, and drawings and capacities are subject to alterations without notice.

The above guidance is based on the current state of knowledge and our best assessment of the potential hazards in the operation of the gear units.

Any further information or clarification required may be obtained by contacting an Application Engineer.

PRODUCTS IN THE RANGE

Serving an entire spectrum of mechanical drive applications from food, energy, mining and metal; to automotive, aerospace and marine propulsion, we are here to make a positive difference to the supply of drive solutions.

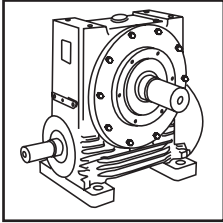

Series A
Worm Gear units
and geared motors
in single & double
reduction types

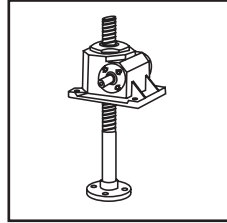

Series BD
Screwjack worm
gear unit

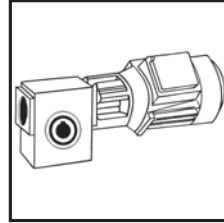

Series BS
Worm gear unit

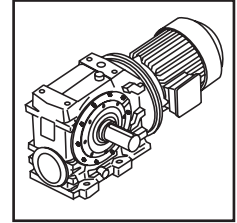

Series C
Right angle drive
helical worm geared
motors & reducers

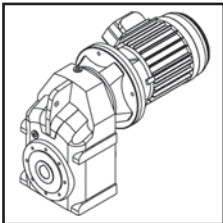

Series F
Parallel angle helical
bevel helical geared
motors & reducers

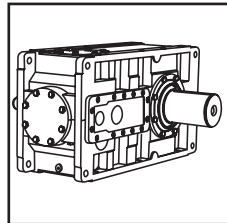

Series G
Helical parallel shaft
& bevel helical right
angle drive gear
units

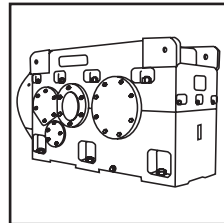

Series H
Large helical parallel
shaft & bevel helical
right angle drive units

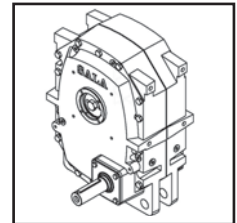

Series J
Shaft mounted
helical speed
reducers

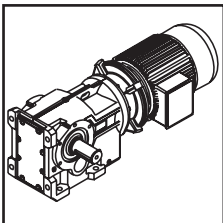

Series K
Right angle helical
bevel helical geared
motors & reducers

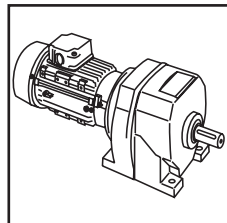

Series M
In-line helical geared
motors & reducers

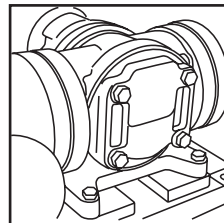

Roloid Gear Pump
Lubrication and fluid
transportation pump

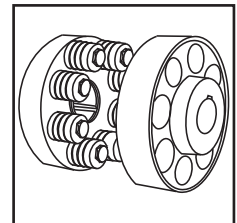

**Series X
Cone Ring**
Pin and bush
elastomer coupling

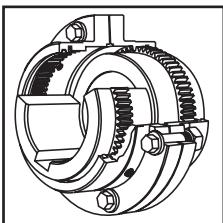

**Series X
Gear**
Torsionally rigid,
high torque coupling

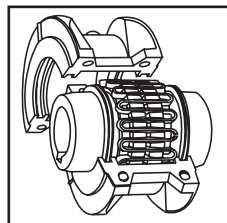

**Series X
Grid**
Double flexing steel
grid coupling

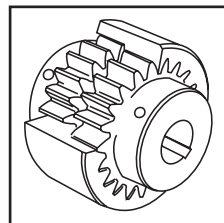

**Series X
Nylon**
Gear coupling with
nylon sleeve

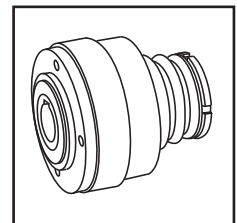

**Series X
Torque Limiter**
Overload protection
device



We offer a wide range of repair services and many years experience of repairing demanding and highly critical transmissions in numerous industries.

We can create custom engineered transmission solutions of any size and configuration.

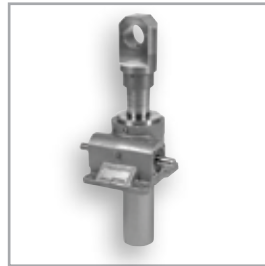

benzlers*
radicon*

BCI_{nv}
elektromotoren

Gentstraat 187
B-8770 Ingelmunster
t +32 0 51 30 49 73
t +32 0 51 30 98 63
f +32 0 51 31 41 02
Info@bcl.be
www.bcl.be