

radicon



with you at every turn

benzlers



with you at every turn

Series A Mid Range Worm Gear

BCI_{nv}
elektromotoren



Technical
Up to - 100kW/ 8500Nm

Worm Gears
CAM-2.00GB1211

PRODUCTS IN THE RANGE

Serving an entire spectrum of mechanical drive applications from food, energy, mining and metal; to automotive, aerospace and marine propulsion, we are here to make a positive difference to the supply of drive solutions.

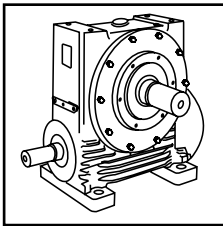

Series A
Worm Gear units
and geared motors
in single & double
reduction types

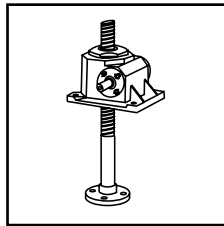

Series BD
Screwjack worm
gear unit

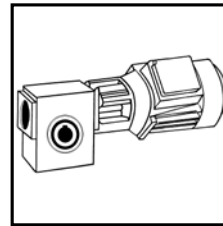

Series BS
Worm gear unit

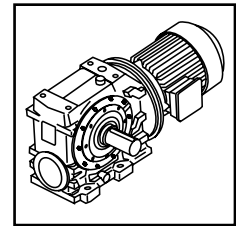

Series C
Right angle drive
helical worm geared
motors & reducers

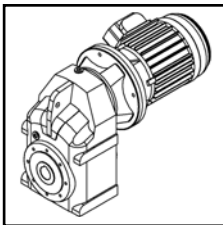

Series F
Parallel shaft helical
geared motors &
reducers

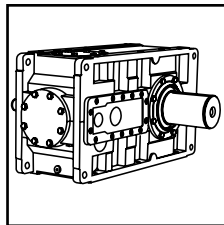

Series G
Helical parallel shaft
& bevel helical right
angle drive gear
units

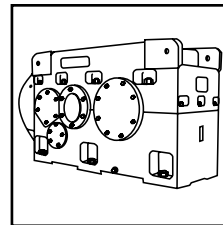

Series H
Large helical parallel
shaft & bevel helical
right angle drive units

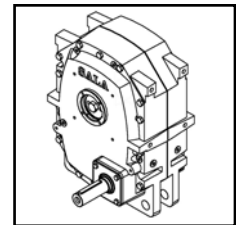

Series J
Shaft mounted
helical speed
reducers

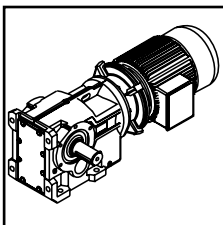

Series K
Right angle helical
bevel helical geared
motors & reducers

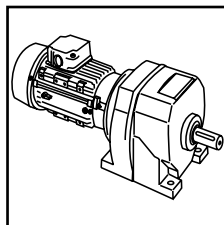

Series M
In-line helical geared
motors & reducers

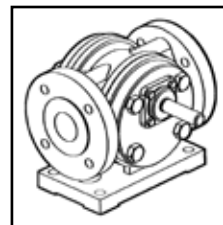

Roloid Gear Pump
Lubrication and fluid
transportation pump

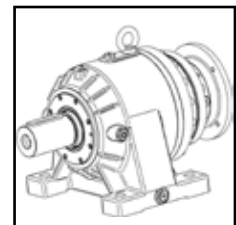

**Series P
Planetary**
Foot and flange
mounted planetary
units

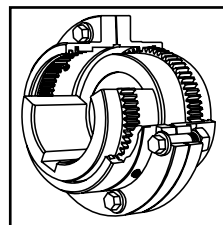

**Series X
Elign Gear**
Torsionally rigid,
high torque coupling

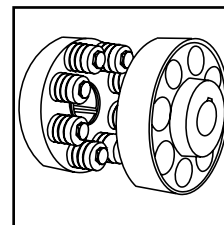

**Series X
Elflex**
Pin and bush
elastomer coupling

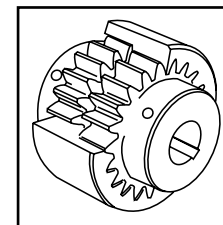

**Series X
Nylicon**
Gear coupling with
nylon sleeve

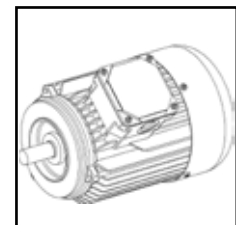

Motors
Full range of IEC
motors



We offer a wide range of repair services and many years experience of repairing demanding and highly critical transmissions in numerous industries.

We can create custom engineered transmission solutions of any size and configuration.

ATEX

Compliance Assured



Total compliance with the ATEX Directive safeguarding the use of industrial equipment in potentially explosive atmospheres is assured for users of our geared products.

Certification is available for standard gearboxes and geared motors with badging displaying the ATEX zone, name and location of the manufacturer, designation of series or type, serial number, year of manufacture, Ex symbol and equipment group/category.

ATEX directive 94/9/EC (also known as ATEX 95 or ATEX 100A) enforced in all EC member states. Compliance is compulsory for designers, manufacturers or suppliers of electrical and non-electrical equipment for use in potentially explosive atmospheres created by the presence of flammable gases, vapours, mists or dusts.

Ex compliant standard gearboxes can be supplied against Groups 2 or 3 for surface industries in designated hazardous location Zones 1 and 2 for gases, vapours and mists; and in Zones 21 and 22 for dusts.

General Description _____	3
Unit Designations _____	4
Explanation and use of Ratings and Service Factors _____	5
Load Classification by Applications _____	6
Moments of Inertia _____	7
Lubrication _____	8
Selection Procedure _____	9 - 10
Mounting Positions and Unit Handings _____	11 - 12
Exact Ratios _____	14
Output Shaft Options and Additional Features _____	15
Motor Performance Data _____	16
Brake Motors / Motors Available _____	17
Standard Motor Variants Available _____	18
Motor Details _____	19
Motor Adaptors _____	20
Overhung and Axial Loads on Shafts _____	21 - 22
Ratings - Input Power / Output Torque _____	23 - 46
Dimension Sheets - Single Reduction _____	47 - 54
Dimension Sheets - Double Reduction _____	55 - 62
Agitator Units Selection _____	63
Torque Arm Banjo Type _____	64
Holdbacks _____	65
Shipping Specification _____	66

GENERAL DESCRIPTION

Single Reduction Units (worm)

This fully metric range of units of 100, 125, 160 and 200 mm centres is based on a single universal case for each size, giving a high degree of common parts and interchangeability. Under-driven, over-driven and vertical types provide a choice of shaft arrangements in meeting the requirements of a wide variety of applications in the medium power range up to 140 kW.

All units are designed with hollow output bore, output shaft can be fitted allowing handing to be changed without dismantling the unit.

Series A Mid Range gives a choice of 12 standard ratios from 5/1 to 70/1 and important features include high efficiencies and load carrying capacities combined with long life and reliability in service.

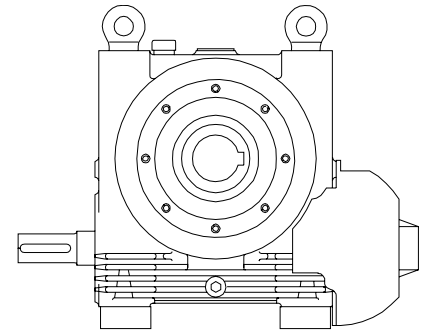

Single Reduction Units (worm)

Double Reduction Units (worm/worm)

These units consist of a standard single reduction unit with a smaller shaft mounted unit fitted to the input shaft. The three smallest sizes are fitted with shaft mounted Series A Junior units whilst the size 2002 is fitted with a size 1002 (C07 when motorised). The range extends the ratios available up to the maximum of 4200/1 making them ideal for fitting to slow moving machinery (Ratios up to 4900/1 are available in size 2002 motorised. Consult our Application Engineers for details).

As with the single reduction units they are available in under-driven, overdriven and vertical types, foot mounting and shaft mounting.

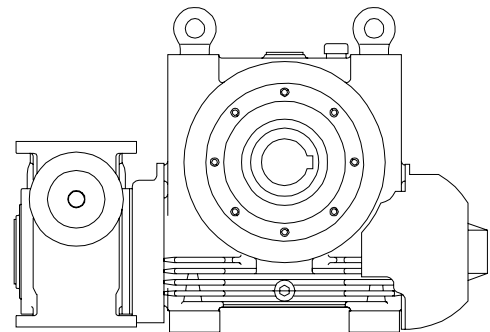

Double Reduction Units (worm/worm)

Heavy Duty Stirrer Units

Based on the standard Series A Mid Range the Heavy Duty Stirrer Unit incorporates an extended bearing housing to accommodate a larger bottom bearing and increased shaft size, thereby enhancing the units capacity to absorb the high bending loads imposed during stirrer applications.

These units can be ordered with a dry-well option to minimise the risk of output shaft leakage.

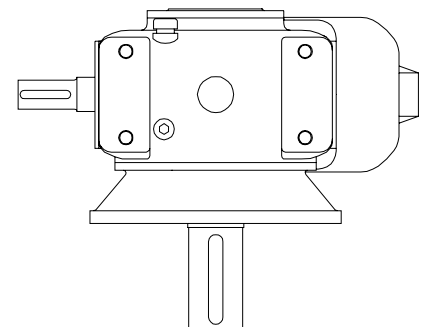

Heavy Duty Stirrer Units

Cooling Tower Fan Drives

Based on the standard Series A Mid Range the Cooling Tower Fan Drive incorporates an extended top bearing housing to accommodate the larger wheelshaft bearing whilst maintaining a compact drive.

Lengths of output shaft extensions are manufactured to clients requirements to suit fan hubs.

Lubrication is entirely contained. Gears and lower bearings dip in the oil bath whilst oil is pumped to the top wheelshaft bearing by means of a built-in mechanical oil pump.

Two oil seals are fitted on both the wheelshaft and wormshaft, the wheelshaft extension incorporating a grease chamber. All exposed parts other than the extensions are finished with corrosion resistant paint. Units are supplied with BSP plugs fitted to the oil filler, drain and ventilator points, suitable for connection to the outsides of towers. Where specified on the order we can supply the necessary piping complete with ventilator, combined dipstick and oil drain.

When selecting a unit, use the selection procedure as detailed on pages 10 - 11 and apply a service factor of 1.75

The ratings for these units are on pages 24 - 47.

Enquiries should include full details of the duty required together with full information regarding ambient temperature at site and whether acids or abrasive solids are likely to be present in the air flow.

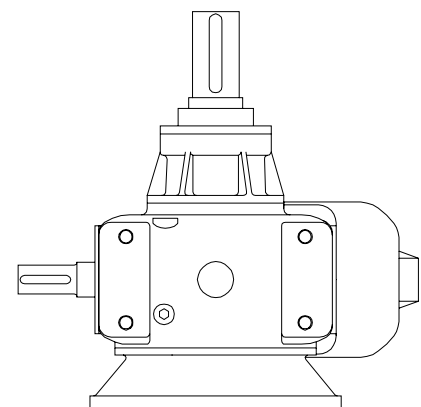

Cooling Tower Fan Drives

UNIT DESIGNATION

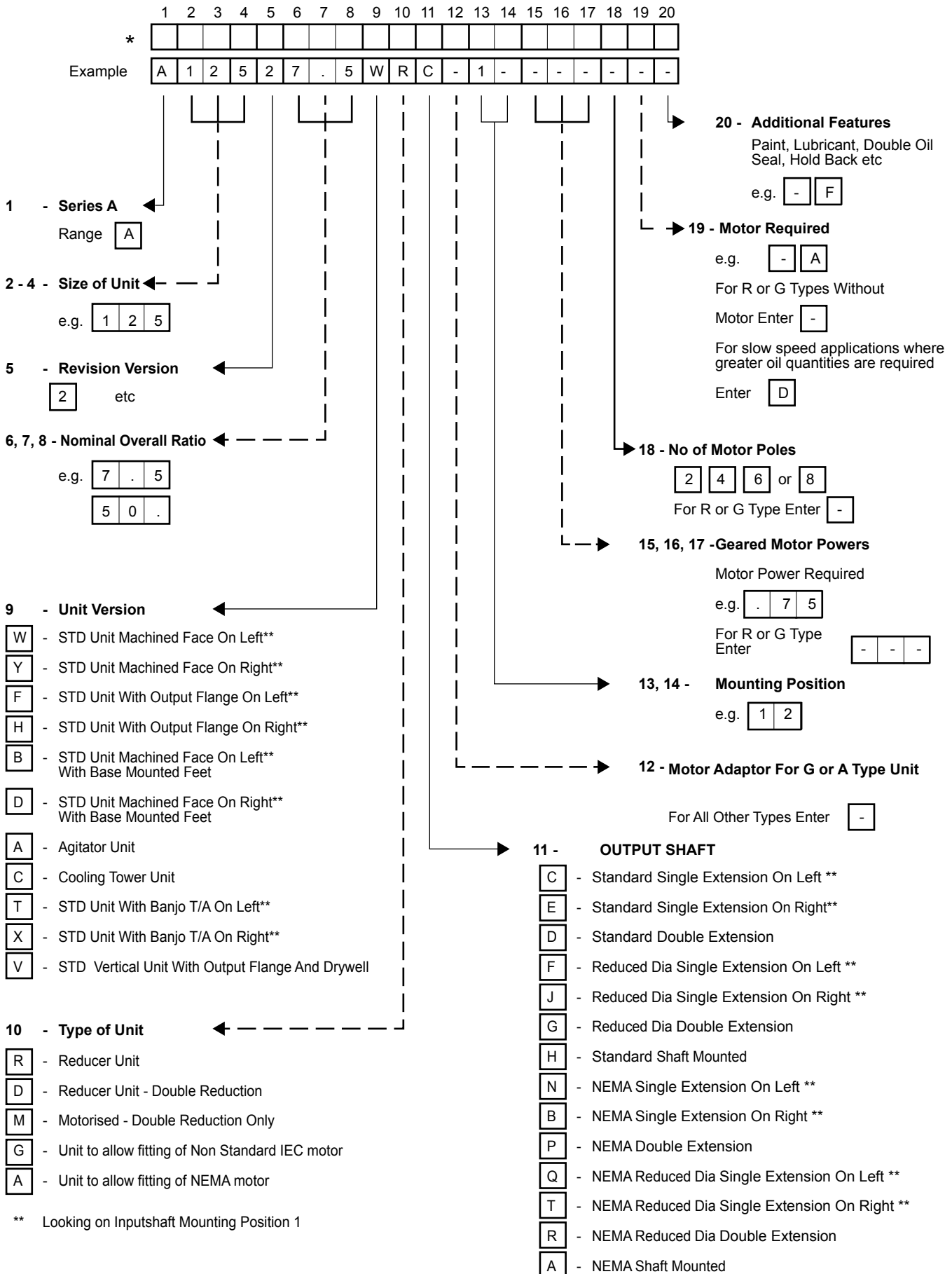

* This Page May Be Photocopied Allowing The Customer To Enter Their Order

SERIES AM

EXPLANATION & USE OF RATINGS & SERVICE FACTORS

Gear unit selection is made by comparing actual loads with catalogue ratings. Catalogue ratings are based on a standard set of loading conditions, whereas actual load conditions vary according to type of application. Service Factors are therefore used to calculate an equivalent load to compare with catalogue ratings. i.e. Equivalent Load = Actual Load x Service Factor

Two types of Service Factor must be considered:- Mechanical Service Factor Fm and Thermal Service Factors Ft, Fp and Fd

Mechanical Ratings and Service Factor Fm

Mechanical ratings measure capacity in terms of life and/or strength, assuming 10 hr/day continuous running under uniform load conditions.

Catalogue ratings allow 100% overload at starting, braking or momentarily during operation up to 10 hours per day.

The unit selected must therefore have a catalogue rating at least equal to half maximum overload.

Mechanical Service Factor Fm (Table 1) is used to modify the actual load according to daily operating time, and type of loading.

Load characteristics for a wide range of applications are detailed in Table 5 opposite, which are used in deciding the appropriate Service Factor Fm from Table 1.

If overloads can be calculated, or accurately assessed, actual loads should be used instead of Fm.

For units subject to frequent stop/start overloads in excess of 10 times per day, refer to our Application Engineers.

For applications where high inertia loads are involved e.g. crane travel drives, slewing motion etc., or when units are to operate in extremely dusty or moist/humid atmospheres, unit selection should be referred to our Application Engineers.

Table1. Mechanical Service Factor Fm

Prime Mover	Duration of service - hrs per day	Load classification-driven machine		
		Uniform	Moderate Shock	Heavy Shock
Electric motor steam turbine or hydraulic motor	Under 3	0.80	1.00	1.50
	3 to 10	1.00	1.25	1.75
	Over 10	1.25	1.50	2.00
Multi-cylinder internal combustion engine	Under 3	1.00	1.25	1.75
	3 to 10	1.25	1.50	2.00
	Over 10	1.50	1.75	2.25
Single cylinder internal combustion engine	Under 3	1.25	1.50	2.00
	3 to 10	1.50	1.75	2.25
	Over 10	1.75	2.00	2.50

Thermal Ratings and Service Factors

The Thermal ratings are a measure of the gear units ability to dissipate heat. If they are exceeded the lubricant may overheat and breakdown, resulting in gear failure.

Thermal factors are for units with fans fitted, un-fanned units to be referred to our Applications department.

To select motorised units the reducer rating tables should be used, pages 24 - 47, referring to the relevant input speed equivalent to motor speed.

Catalogue thermal limitations are based on the unit operating continuously in an environment with an ambient temperature equal to 20°C and in mounting position 1. The thermal rating is affected by ambient temperature, duration of running per hour and mounting position. To account for these varying conditions, the service factors given in tables 2, 3 and 4 should be applied to the catalogue thermal ratings as follows:-

$$T_{\text{therm}} = T_t \times F_t \times F_p \times F_d$$

Tt = Catalogue output torque thermal rating (Nm)

Ttherm = Allowable output torque thermal rating (Nm)

Ft = Service factor for ambient temperature (see Table 2)

Fp = Service factor for different mounting positions (see Table 3)

Fd = Thermal service factor for duration of running (see Table 4)

Double Reduction Units

For double reduction units the factors given in tables 2 and 4 apply. The input shaft speed referred to in table 4 should now be the input speed of the primary unit. New factors should be applied for mounting position (Fp), which refer to the position of the primary unit.

i Inputshaft horizontal and wheel- line horizontal Fp = 1.0

ii Inputshaft horizontal and wheel-line vertical Fp = 0.88

iii Inputshaft vertical and wheel-line horizontal Fp = 0.68

General

When selecting units, use actual load required to be transmitted, not rating of prime mover. Wherever possible use required output torque (Nm). Catalogue also gives input power rating (kW), being power required from mover allowing for gear unit efficiency. When units transmit less than rated output torque, required input power may be reduced pro-rata to decide capacity of prime mover.

Table2. Thermal Service Factor Ft

Ambient temperature °C	-30	-20	-10	0	10	20	30	40	50
Factor Ft	1.65	1.52	1.39	1.26	1.14	1.0	0.86	0.73	0.60

Table3. Thermal Service Factor Fp (Single Reduction units)

Output Speed (rev/min)	Mounting Position (see pages 12 and 13)			
	1	2	3 & 4	5 & 6
0 to 100	1.0	0.91	0.71	Refer to our Applications Department
>100 to 200	1.0	0.89	0.69	
>200 to 300	1.0	0.85	0.66	
>300 to 400	1.0	0.82	0.62	
>400 to 500	1.0	0.77	0.57	
>500 to 600	1.0	0.72	0.52	
>600 to 700	1.0	0.65	0.46	
>700	1.0	0.58	0.39	

Table4. Thermal Service Factor Fd

Input shaft speed (Rev/min)	Unit Size	% Running time per hour					
		>60	>50-60	>40-50	>30-40	>20-30	<20
100	all	1.0	1.45	1.70	1.95	2.30	2.82
400	all	1.0	1.35	1.50	1.68	1.89	2.24
725	all	1.0	1.29	1.40	1.53	1.70	1.96
960	all	1.0	1.25	1.34	1.45	1.60	1.82
1160	all	1.0	1.23	1.31	1.40	1.54	1.75
1450	all	1.0	1.20	1.26	1.33	1.45	1.62
1750	1002/1252	1.0	1.19	1.25	1.31	1.43	1.59
	1602/2002	1.0	1.16	1.21	1.27	1.37	1.50
2900	1002/1252	1.0	1.11	1.14	1.16	1.24	1.33
	1602/2002	1.0	1.07	1.08	1.10	1.24	1.20

SERIES AM

LOAD CLASSIFICATION BY APPLICATIONS

Table 5

U = Uniform load

M = Moderate shock load

H = Heavy shock load

† = Refer to Application Engineering

Driven Machine	type of load	Driven Machine	type of load	Driven Machine	type of load
Agitators pure liquids liquids and solids liquids-variable density	U M M	Cranes main hoists bridge travel trolley travel	U † †	log haul-incline log haul-well type log turning device main log conveyor off bearing rolls planer feed chains planer floor chains planer tilting hoist re-saw merry-go-round conveyor roll cases slab conveyor small waste conveyor-belt small waste conveyor-chain sorting table tippie hoist conveyor tippie hoist drive transfer conveyors transfer rolls tray drive trimmer feed waste conveyor	H H H H M M M M M M H H U M M M M M M M M M M
Blowers centrifugal lobe vane	U M U	Crusher ore stone sugar	H H H	log haul presses pulp machine reel stock chest suction roll washers and thickeners winders	H M M M M M M
Brewing and distilling bottling machinery brew kettles-continuous duty cookers-continuous duty mash tubs-continuous duty scale hopper-frequent starts	U U U U M	Dredges cable reels conveyors cutter head drives jig drives manoeuvring winches pumps screen drive stackers utility winches	M M H H H M M M M	Printing presses	†
Can filling machines	U	Elevators bucket-uniform load bucket-heavy load bucket-continuous centrifugal discharge escalators freight gravity discharge man lifts passenger	U M U U U U M U †	Pullers barge haul	H
Cane knives	M	Fans centrifugal cooling towers induced draft forced draft induced draft large, mine, etc large, industrial light, small diameter	U U † † M M U	Pumps centrifugal proportioning reciprocating single acting; 3 or more cylinders double acting; 2 or more cylinders single acting; 1 or 2 cylinders double acting; single cylinder rotary gear type lobe, vane	U M M M M M † U U
Car dumpers	H	Feeder apron belt disc reciprocating screw	M M U M	Rubber and plastics industries crackers laboratory equipment mixed mills refiners rubber calenders rubber mill-2 on line rubber mill-3 on line sheeter tire building machines tire and tube press openers tubers and strainers warming mills	H M M M M M M M M M
Car pullers	M	Food industry beef slicer cereal cooker dough mixer meat grinders	M M M M	Sand muller	M
Clarifiers	U	Generators-not welding	U	Sewage disposal equipment bar screens chemical feeders collectors dewatering screws scum breakers slow or rapid mixers thickeners vacuum filters	U U U M M M M M
Classifiers	M	Hammer mills	H	Screens air washing rotary-stone or gravel travelling water intake	U M U
Clay working machinery brick press briquette machine clay working machinery pug mill	H H M M	Hoists heavy duty medium duty skip hoist	H M M	Slab pushers	M
Compressors centrifugal lobe reciprocating multi-cylinder single cylinder	U M M H	Laundry washers reversing	M	Steering gear	†
Conveyors-uniformly loaded or fed apron assembly belt bucket chain flight oven screw	U U U U U U U U	Laundry tumblers	M	Stokers	U
Conveyors-heavy duty not uniformly fed apron assembly belt bucket chain chain flight live roll oven reciprocating screw shaker	M M M M M M M H M M M M	Line shafts driving processing equipment light other line shafts	M U U	Sugar industry cane knives crushers mills	M M M
		Lumber industry bark-hydraulic-mechanical burner conveyor chain saw and drag saw chain transfer craneway transfer de-barking drum edger feed gang feed green chain live rolls log deck	M M H H H H M M M M H H H	Textile industry batchers calenders cards dry cans dryers dyeing machinery knitting machines looms mangles nappers pads range drives slashers soapers spinners tenter frames washers winders	M M M M M M † M M M M M M M
		Metal mills draw bench carriage and main drive pinch, dryer and scrubber rolls-reversing slitters table conveyors non-reversing group drives individual drives reversing wire drawing and flattening machine wire winding machine	M H † M M M H H	Windlass	†

MOMENTS OF INERTIA (kg cm²) Referred to Input Shaft

SINGLE REDUCTION

RATIO	A1002	A1252	A1602	A2002
5	17.93	49.98	120.31	287.40
7.5	13.79	37.87	76.74	176.60
10	11.02	30.66	63.31	142.43
12.5	10.12	27.88	54.51	118.78
15	9.98	24.97	52.66	102.11
20	8.62	23.37	51.48	96.18
25	9.38	23.85	46.57	87.37
30	8.57	23.15	52.76	99.09
40	8.33	20.88	46.46	82.47
50	7.77	20.33	41.50	74.98
60	7.62	19.63	40.13	70.81
70	7.94	19.22	42.93	68.22

DOUBLE REDUCTION

RATIO	A1002	A1252	A1602	A2002 REDUCER	A2002 MOTORISED
75	0.54	1.25	2.88	5.94	37.32
100	1.52	3.59	8.39	17.17	36.94
125	0.53	1.23	2.79	5.75	23.95
150	0.80	1.72	4.22	10.92	17.40
200	0.79	1.71	4.21	10.85	36.44
225	0.21	0.53	1.17	3.40	18.51
250	0.24	0.60	1.28	3.23	17.26
300	0.78	1.22	2.61	8.59	23.59
350	0.51	1.17	2.74	5.51	22.13
375	0.24	0.59	1.27	3.21	21.75
400	0.78	1.22	2.61	8.58	36.24
450	0.21	0.53	1.17	3.39	18.41
500	0.27	0.42	0.89	2.92	17.18
600	0.49	1.11	2.55	8.32	2.92
625	0.24	0.59	1.27	3.20	21.72
700	0.13	0.33	0.71	2.71	22.06
750	0.15	0.34	0.74	2.65	12.75
800	0.48	1.11	2.55	8.32	17.17
900	0.13	0.33	0.69	2.60	18.37
1000	0.17	0.38	0.87	2.84	17.15
1200	0.48	1.11	2.55	8.32	17.14
1250	0.15	0.34	0.74	2.65	3.65
1400	0.13	0.33	0.71	2.71	20.57
1500	0.13	0.33	0.69	2.60	3.66
1600	0.48	1.11	2.55	8.31	5.41
1750	0.13	0.33	0.70	2.71	20.57
1800	0.13	0.33	0.69	2.60	4.03
2000	0.15	0.34	0.74	2.65	16.47
2100	0.13	0.33	0.71	2.71	3.04
2400	0.38	0.97	2.03	7.61	2.91
2500	0.15	0.34	0.74	2.65	3.65
2800	0.13	0.33	0.70	2.71	5.91
3000	0.38	0.97	2.03	7.60	3.64
3500	0.13	0.33	0.70	2.71	3.64
3600	0.13	0.33	0.69	2.60	3.03
4200	0.38	0.96	2.06	7.92	3.03

LUBRICANT AND QUANTITY

The Series A Mid Range units are despatched without oil. The oil grade is stamped on the name plate and the oil level marked on the dipstick. These are determined from the operating speed of the gear unit and the ambient temperature range, which if not given when ordering will be assumed to be 1450 rev / min input and ambient temperature range 0 to 35°C. Oil grades and oil level should therefore always be checked before installation, instructions are provided with all units despatched.

To determine the oil grade refer to the appropriate table 1 or 2 below, and then subsequently to table 3 which gives approved lubricants. To determine the oil capacity refer to appropriate table 4 or 5 which should be read in conjunction with the notes given. Oil capacities are only approximate and units should be filled to the levels marked on the dipstick. Do not overfill as excess will cause overheating and leakage.

TABLE 1 - OIL GRADE
SINGLE REDUCTION UNITS, DOUBLE REDUCTION WORM/
WORM, SECONDARY UNITS SIZES 1002, 1252, AND 1602

Ambient Temperature	Wormshaft speed*		
	Above 750 rev/min	750 rev/min - 300 rev/min	Below 300 rev/min
-30 to 20°C	4G	5G	6G
0 to 35°C	5G	6G	7G
20 to 50°C	6G	7G	8G

* The secondary wormshaft speed for the worm/worm units can be calculated using the primary unit ratios given on page 15

TABLE 2 - OIL GRADE
TRIPLE REDUCTION HELICAL/WORM/WORM SIZE
2002 DOUBLE REDUCTION WORM/WORM SIZE 2002

Ambient Temperature	Wormshaft speed*		
	Above 1800 rev/min	1800 rev/min - 500 rev/min	Below 500 rev/min
-30 to 20°C	4G	5G	6G
0 to 35°C	5G	6G	7G
20 to 50°C	6G	7G	8G

TABLE 3 - APPROVED LUBRICANTS
TYPE G - POLYGLYCOL BASE SYNTHETIC

* Only one grade available hence no grade designation

LUBRICANT SUPPLIER	LUBRICANT RANGE NAME	GRADE No				
		4G	5G	6G	7G	8G
Batoyle Freedom Group	Helicol W	* (-15)				
Boxer Services / Millers Oils Ltd	Boxergear W	150 (-15)	220 (-31)	320 (-31)	460 (-28)	
BP Oil International Limited	Energyn SG-XP		220 (-31)		460 (-34)	680 (-28)
Caltex	Synlube CLP	150 (-37)	220 (-34)	320 (-31)	460 (-28)	680 (-31)
Carl Bechem GmbH	Berusynth EP	150 (-26)	220 (-25)	320 (-25)	460 (-25)	680 (-28)
Castrol International	Alphasyn PG	150 (-34)	220 (-34)	320 (-31)	460 (-28)	
Esso/Exxon	Glycolube	150 (-25)	220 (-25)	320 (-25)	460 (-23)	
Fuchs Lubricants	Renogear PGW	120 (-23)				
	Renolin PG	150 (-34)	220 (-34)	320 (-34)	460 (-34)	680 (-28)
Klüber Lubrication	Klübersynth GH6	150 (-30)	220 (-25)	320 (-25)	460 (-20)	680 (-20)
	Klübersynth UH 1 6		220 (-30)	320 (-25)	460 (-25)	
Kuwait Petroleum International	Q8 Gade		220 (-22)	320 (-22)	460 (-22)	
Laporte Performance Chemicals Limited	Breox Worm Gear Lube	65 (-25)				
	Breox Industrial Lubricant Sw	150 (-25)	220 (-25)	320 (-25)	460 (-23)	
	Breox Oil Soluble Industrial Lub		220 (-23)			
Mobil Oil Company Limited	Glygoyle	22 (-25)	30 (-22)	HE320 (-37)	HE460 (-35)	
Optimol Ölwerke GmbH	Optiflex A	150 (-31)	220 (-28)	320 (-28)	460 (-28)	680 (-28)
Shell Oils	Tivela	SA (-25)	SB (-25)	SC (-25)	SD (-23)	
	Tivela S	150 (-40)	220 (-34)	320 (-34)	460 (-34)	680 (-34)
Texaco Limited	Synlube CLP	150 (-37)	220 (-34)	320 (-31)	460 (-28)	680 (-31)
Total	Carter SY		220 (-25)	320 (-28)	460 (-22)	
Tribol GmbH	Tribol 800	150 (-37)	220 (-27)	320 (-25)	460 (-25)	680 (-25)

TABLE 4 - LUBRICANT QUANTITY (Litres) SINGLE REDUCTION

Number in brackets indicates recommended minimum operating temperature

Mounting Position See Page 12, 13 & 14	Size of Unit			
	1002	1252	1602	2002
1	1.8 (2.3)	3.2 (4.1)	5.4 (7.9)	8.0 (12)
2	2.0 (3.3)	4.0 (6.6)	7.0 (13)	11.4 (21.5)
3 & 4	1.7 (2.1)	3.6 (3.7)	6.6 (7.8)	10 (11.5)
5, 6 & Cooling Tower	REFER TO OUR APPLICATION ENGINEERS			
Aqitator	1.8 (2.1)	3.8 (4.0)	6.7 (7.4)	9.2 (10.7)

Figures in brackets refer to: - Mounting position 2 with output shaft speed of 100 rev/min and below (A1002 7 A1252), or 15 rev/min and below (A1602 & A2002)
- Mounting positions 1, 3 and 4 with input shaft speed of 600 rev/min and below

} enter in column 19

TABLE 5 - LUBRICANT QUANTITY (Liters) DOUBLE REDUCTION

Mounting Position See Pages 12, 13 & 14	Unit stage	Size of Unit				
		1002	1252	1602	2002 Reducer	2002 Motorised
Secondary unit	Primary unit					
	Primary	*	*	*	1.8 (2.3)	3.8
1	1 and 5	Primary	*	*	*	†
	2 and 8	Primary	*	*	*	†
	3 and 7	Primary	*	*	*	2.0 (3.3)
	4 and 6	Primary	*	*	*	†
		Secondary	2.3	4.1	7.9	†
2	1 and 5	Primary	*	*	*	1.8 (2.3)
	2 and 8	Primary	*	*	*	†
	3 and 7	Primary	*	*	*	2.0 (3.3)
	4 and 6	Primary	*	*	*	†
		Secondary	3.3	6.6	13.0	21.5
3 & 4	1 and 5	Primary	*	*	*	1.8 (2.3)
	2 and 8	Primary	*	*	*	†
	3 and 7	Primary	*	*	*	2.0 (3.3)
	4 and 6	Primary	*	*	*	†
		Secondary	2.1	3.7	7.8	11.5
5 & 6	1 and 5	Primary				
	2 and 8	Primary				
	3 and 7	Primary				
	4 and 6	Primary				
		Secondary				

† Refer to our Application Engineers * No oil required factory filled with lubricant
Figures in brackets are for the primary units with an output speed 100rev/min and below.

SELECTION PROCEDURE

EXAMPLE APPLICATION DETAILS

Absorbed power of driven machine = 3.9kW
 Output speed of gearbox or Input speed of machine = 20rpm
 Application = Heavy duty, non uniformly fed bucket conveyor
 Duration of service (hours per day) = 10hrs
 Motor speed = 3 phase electric motor, 4 pole, 1450rpm
 Mounting position = 2
 Ambient temperature = 20°C
 Running time (%) = 100%

1 DETERMINE RATIO OF GEARBOX REQUIRED

$$\frac{\text{Motor Speed}}{\text{Gearbox Output Ratio}} = \frac{1450}{20} = 72$$

Refer to exact ratios (page 15) for nearest standard ratio = 70;1

3 DETERMINE REQUIRED OUTPUT TORQUE AT GEARBOX OUTPUT SHAFT

$$\text{Absorbed output torque} = \frac{\text{Absorbed power} \times 9550}{\text{Gearbox output speed}}$$

$$20 = \frac{3.9 \times 9550}{1862 \text{ Nm}}$$

Required mechanical output torque = Absorbed output x Fm torque

$$1862 \times 1.25 = 2328 \text{ Nm}$$

2 DETERMINE MECHANICAL SERVICE FACTOR (Fm)

Refer to Load Classification by Application, table 5, page 7

Application = Heavy duty, non uniformly fed bucket conveyor

Conveyors-heavy duty not uniformly fed		M = Moderate shock loading
apron	M	
assembly	M	
belt	M	
bucket	M	
chain	M	

Refer to mechanical service factor (Fm), table 1, page 6

Duration of service (hours per day) = 10hrs

Prime mover	Duration of service-hrs per day	Load classification-drive	
		Uniform	Moderate Shock
Electric motor, steam turbine or hydraulic motor	Under 3	0.80	1.00
	3 to 10	1.00	1.25
	Over 10	1.25	1.50

Therefore mechanical service factor (Fm) = 1.25

4 DETERMINE SIZE OF GEARBOX REQUIRED

Refer to ratings tables, Input speed = 1450rpm, therefore refer to page 30.

NOMINAL RATIO	NOMINAL OUTPUT SPEED REV / MIN	CAPACITY		SIZE OF UNIT				
				A1002	A1252	A1602	A2002	
70.0	20.71	Mechanical	Input Power kW	2.03	3.45	7.81	11.50	
			Output Torque Nm	659.	1190.	2700.	4180.	
		Thermal	Input Power kW	3.46	5.85	8.29	15.70	
			Output Torque Nm	1150.	2060.	2870.	5810.	
		Efficiency %			70	75	75	79

Mechanical output torque capacity must be equal or more than required mechanical output torque capacity of gear box. Required mechanical output torque capacity = 2328Nm. At a 70:1 ratio, nominal output speed 20.71 an A1602 unit has a mechanical output torque capacity of 2700Nm. Therefore the unit is acceptable

4 DETERMINE EXACT RATIO OF GEARBOX

Refer to exact ratios table, page 15.

Nominal Ratio Column Entry	Size 1002	Size 1252	Size 1602	Size 2002
	Exact Ratio	Exact Ratio	Exact Ratio	Exact Ratio
6 7 8	70	70	70	70

Exact ratio = 70.0:1

4 CHECK THERMAL CAPACITY OF GEARBOX SELECTED DETERMINE THERMAL OUTPUT TORQUE CAPACITY (Tt)

Refer to ratings tables,

NOMINAL RATIO	NOMINAL OUTPUT SPEED REV / MIN	CAPACITY		SIZE OF UNIT				
				A1002	A1252	A1602	A2002	
70.0	20.71	Mechanical	Input Power kW	2.03	3.45	7.81	11.50	
			Output Torque Nm	659.	1190.	2700.	4180.	
		Thermal	Input Power kW	3.46	5.85	8.29	15.70	
			Output Torque Nm	1150.	2060.	2870.	5810.	
		Efficiency %			70	75	75	79

Tt = 2870Nm

Go to point 7

SELECTION PROCEDURE

7 DETERMINE THERMAL SERVICE FACTOR (Ft)

Refer to table 2, page 6
Ambient temperature = 20°C

Ambient temperature °C	-30	-20	-10	0	10	20
Factor Ft	1.65	1.52	1.39	1.26	1.14	1.0

Ft = 1.0

8 DETERMINE THERMAL SERVICE FACTOR (Fp)

Refer to table 3, page 6
Mounting position = 2
Nominal Output Speed (rev/min) = 20.71

Output Speed (rev/min)	Mounting	
	1	2
0 to 100	1.0	0.91
>100 to 200	1.0	0.89
>200 to 300	1.0	0.85

Fp = 0.91

9 DETERMINE THERMAL SERVICE FACTOR (Fd)

Refer to table 4, page 6
& running time = 100

Input shaft speed (Rev/min)	% Running time per hour		
	>60	>50-60	>40-50
1450	1.0	1.20	1.26
1750	1.0	1.19	1.25

Fd = 1.0

10 DETERMINE ALLOWABLE OUTPUT TORQUE THERMAL RATING (Tthem)

$$T_{them} = T_t \times F_t \times F_p \times F_d$$

$$= 2870 \times 1.0 \times 0.91 \times 1.0$$

$$= 2612 \text{ Nm}$$

Thermal output torque capacity (Tthem) must be equal or more than absorbed output torque to drive machine

Absorbed output torque = 1862Nm (see step 3) Tthem = 2612Nm

Therefore unit is acceptable

11 DETERMINE REQUIRED POWER OF ELECTRIC MOTOR

Refer to ratings tables to determine gear unit efficiency

NOMINAL RATIO	NOMINAL OUTPUT SPEED REV / MIN	CAPACITY	SIZE OF UNIT				
			A1002	A1252	A1602	A2002	
70.0	20.71	Mechanical	Input Power kW	2.03	3.45	7.81	11.50
			Output Torque Nm	659	1190	2700	4180
		Thermal	Input Power kW	3.46	5.85	8.29	15.70
			Output Torque Nm	1150	2060	2870	5810
			Efficiency %	70	75	75	79

$$\text{Efficiency \%} = 75 \quad \text{Required motor power} = \frac{\text{Absorbed power of driven machine} \times 100}{\text{Efficiency}} = \frac{3.9 \times 100}{75} = 5.2 \text{ kW}$$

The next largest standard motor power available is selected 5.5kW

12 CHECK MOMENTARY OVERLOAD CAPACITY

Convert normal motor capacity (kW) to torque (Nm) at gearbox output shaft

$$\text{Normal output torque} = \frac{\text{Normal motor capacity} \times 9550 \times \text{Efficiency}}{\text{Output speed of gearbox} \times 100} = \frac{5.5 \times 9550 \times 75}{20 \times 100} = 1970 \text{ Nm}$$

Refer to motor performance data

kW COLUMN ENTRY	MOTOR FRAME SIZE	FULL LOAD SPEED	FLC (AMPS) 400 VOLTS	EFFICIENCY %			POWER FACTOR			D.O.L. STARTING % OF FULL LOAD		STAR DELTA STARTING % OF FULL LOAD		PULL UP TORQUE % FL
				FL	3/4 L	1/2 L	FL	3/4 L	1/2L	LRT	LRC	LRT	LRC	
5	132	2900	11.8	83	82.5	80	0.82	0.75	0.64	340	700	100	220	280
	132	1450	11.85	85	85.5	85	0.79	0.72	0.59	260	650	80	200	180
	132	960	13	81	80	79	0.76	0.66	0.54	260	660	80	210	180

$$\text{Maximum motor starting torque} = \text{Pull up torque} \times \text{Normal output torque} = 1.8 \times 1970 = 3545 \text{ Nm}$$

Gearbox will accept 2 x Momentary overload (10 times / day maximum)

$$\text{Peak allowable torque} = 2 \times \text{mechanical gearbox rating (see step 4)} = 2 \times 2700 = 5400 \text{ Nm}$$

Maximum motor starting torque must be equal or less than peak allowable torque

$$\text{Peak allowable torque} = 5400 \text{ Nm}$$

$$\text{Maximum motor starting torque} = 3545 \text{ Nm}$$

Therefore the unit is acceptable

13 CHECK PHYSICAL DIMENSIONS IF MOTORISED

For motorised units check on dimension pages that the gearbox will accept the dimensions of the motor frame required

14 CHECK OVERHUNG LOADS

If sprocket, gear, etc is mounted on the input or output shaft then refer to Overhung loads procedure, page 22

NOTE: If any of the following conditions occur then consult Application Engineering:-

- a) Inertia of the Driven Machine (Referred to motor speed) > 10
- b) Ambient temperature is above 50°C
- or
- c) The unit is required without a fan

SERIES AM

MOUNTING POSITIONS

Column 13 Entry	Unit Version - Column 9 Entry					
	Basic Unit	Base mounted feet	Output flange		Banjo torque arm	
1	W	B	F	H	T	X
	Y	D				
2	W	B	F	H	T	X
	Y	D				
3	W	B	F	H	T	X
	Y	D	Enter V for drywell A for agitator C for cooling tower	Enter V for drywell A for agitator C for cooling tower	-	-
4	W	B	F	H	T	X
	Y	D			-	-
5	W	B	F	H	T	X
	Y	D				
6	W	B	F	H	T	X
	Y	D				

SERIES AM

UNIT HANDINGS - OUTPUT SHAFT POSITIONS

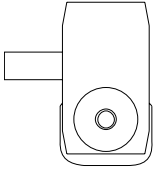
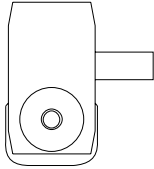
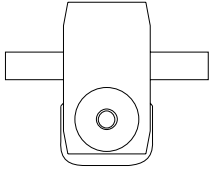
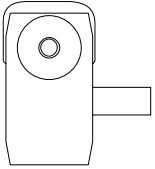
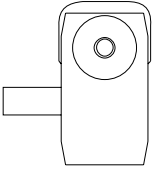
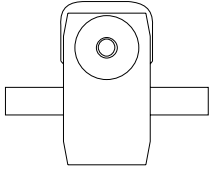
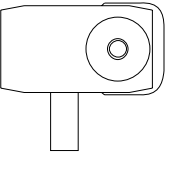
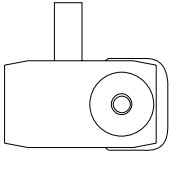
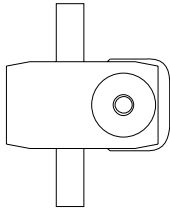
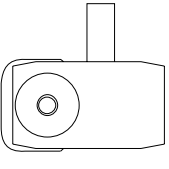
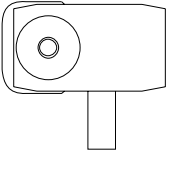
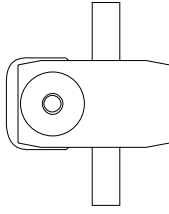
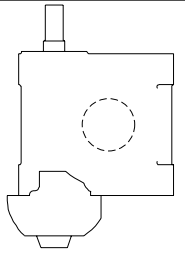
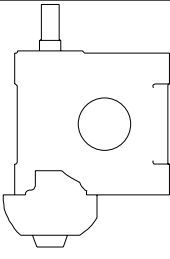
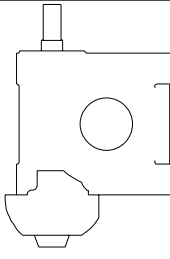
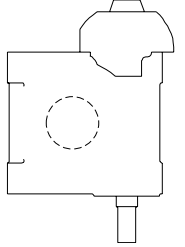
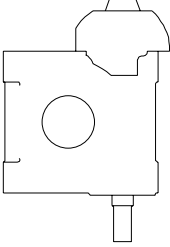
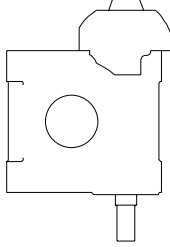
Column 13 Entry	Output Shaft Positions - Column 11 Entry		
	C (F) Single extension	E (J) Single extension	D (G) Double extension
1			
2			
3			
4			
5			
6			

Letters in brackets indicate reduced diameter output shafts, see page 16 for details.

SERIES AM

DOUBLE REDUCTION PRIMARY UNIT MOUNTING POSITIONS

Column 13 Entry	Primary Unit Mounting Position - Column 14 Entry							
	1	2	3	4	5	6	7	8
1								
2								
3								
4								
5								
6								

FOR SINGLE REDUCTION ENTER - IN COLUMN 14

SIZE 2002 MOTORISED, ONLY PRIMARY MOUNTING POSITIONS 1, 2, 3 AND 4 ARE AVAILABLE

Single Reduction (worm)

Nominal Ratio Column Entry 6 7 8	Size 1002	Size 1252	Size 1602	Size 2002
	Exact Ratio	Exact Ratio	Exact Ratio	Exact Ratio
5 . 0	5.143	5.125	5.125	5.1
7 . 5	7.4	7.4	7.571	7.571
1 0 .	9.75	9.75	9.8	9.8
1 2 .	12.333	12.333	12.25	12.25
1 5 .	15.5	15.5	14.667	15.333
2 0 .	19.5	19.5	20.5	20.5
2 5 .	25	25	24.5	24.5
3 0 .	30	30	30	30
4 0 .	40	40	40	40
5 0 .	50	50	50	50
6 0 .	60	60	60	60
7 0	70	70	70	70

Double Reduction (worm/worm)

Nominal Ratio	Column Ratio			Primary & Secondary Nominal Ratio	Size 1002	Size 1252	Size 1602	Size 2002 Reducer	Size 2002 Motorised (helical worm/worm)	
	6	7	8		Exact Ratio	Exact Ratio	Exact Ratio	Exact Ratio	Primary & Secondary Nominal Ratio	Exact Ratio
75	7	5	.	5 x 15	77.5	80.6	70.89	78.86	8 x 10	77.43
100	1	0	0	5 x 20	97.5	101.4	99.08	105.4	8 x 12.5	96.79
125	1	2	5	5 x 25	125	130	118.4	126	12 x 10	120.5
150	1	5	0	10 x 15	149.8	160.2	141.8	149.5	20 x 7.5	152.0
200	2	0	0	10 x 20	188.5	201.5	198.2	199.9	8 x 25	193.6
225	2	2	5	15 x 15	232.5	224.8	212.7	237.7	18 x 12.5	216.3
250	2	5	0	25 x 10	243.8	243.8	245	245	20 x 12.5	245.9
300	3	0	0	20 x 15	310	302.3	286	299	12 x 25	301.2
350	3	5	0	5 x 70	350	364	338.3	360	14 x 25	331.2
375	3	7	5	25 x 15	387.5	387.5	366.7	383.3	25 x 15	377.0
400	4	0	0	20 x 20	390	380.3	399.8	399.8	8 x 50	395.0
450	4	5	0	15 x 30	450	435	435	465	10 x 25	432.6
500	5	7	0	20 x 25	500	487.5	477.8	477.8	20 x 25	491.8
600	6	0	0	40 x 15	620	620	586.7	613.3	80 x 75	572.1
625	6	2	5	25 x 25	625	625	612.5	612.5	25 x 25	602.4
700	7	0	0	70 x 10	682.5	682.5	686	686	14 x 50	675.9
750	7	5	0	50 x 15	775	775	733.3	766.7	50 x 15	765.1
800	8	0	0	40 x 20	780	780	820	820	20 x 40	802.9
900	9	0	0	60 x 15	930	930	880	920	18 x 50	882.8
1000	1	0	C	40 x 25	1000	1000	980	980	20 x 50	1004.
1200	1	2	C	40 x 30	1200	1200	1200	1200	20 x 60	1204.
1250	1	3	C	50 x 25	1250	1250	1225	1225	50 x 25	1222.
1400	1	4	C	70 x 20	1365	1365	1435	1435	28 x 50	1352.
1500	1	5	C	60 x 25	1500	1500	1470	1470	50 x 30	1497.
1600	1	6	C	40 x 40	1600	1600	1600	1600	32 x 50	1541.
1750	1	7	C	70 x 25	1750	1750	1715	1715	28 x 60	1622.
1800	1	8	C	60 x 30	1800	1800	1800	1800	45 x 40	1765.
2000	2	0	C	50 x 40	2000	2000	2000	2000	40 x 50	2007.
2100	2	1	C	70 x 30	2100	2100	2100	2100	71 x 30	2070.
2400	2	4	C	60 x 40	2400	2400	2400	2400	80 x 30	2267.
2500	2	5	C	50 x 50	2500	2500	2500	2500	50 x 50	2495.
2800	2	8	C	70 x 40	2800	2800	2800	2800	56 x 50	2681.
3000	3	0	C	60 x 50	3000	3000	3000	3000	50 x 60	2994.
3500	3	5	C	70 x 50	3500	3500	3500	3500	50 x 70	3493.
3600	3	6	C	60 x 60	3600	3600	3600	3600	71 x 50	3450.
4200	4	2	C	70 x 60	4200	4200	4200	4200	71 x 60	4140.

NOMINAL RATIO ENTERED IN COLUMNS

6	7	8
---	---	---

SERIES AM

OUTPUT OPTIONS

ADDITIONAL FEATURES

OUTPUT OPTIONS, COLUMN 11 ENTRY

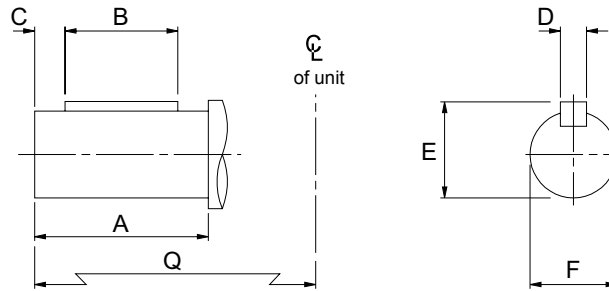

SIZE OF UNIT	TYPE OF OUTPUT SHAFT	COLUMN 11 ENTRY		DIMENSIONS IN MM (INCH SHAFTS IN INCHES)						
		Single Ext	Double Ext	A	B	C	D	E	øF	Q
A1002	Standard	C, E	D	110	86	10	14.000 / 13.957	53.50 / 53.21	50.018 / 50.002	225
	Reduced Dia.	F, J	G	82	56	10	14.000 / 13.957	48.50 / 48.21	45.018 / 45.002	215
	Inch *	N, B	P	4.33	3.88	-	.501 / .500	2.219 / 2.212	2.0 / 1.9993	8.86
	Inch Red. Dia. *	Q, T	R	3.23	2.69	-	.376 / .375	1.913 / 1.906	1.75 / 1.7494	8.46
A1252	Standard	C, E	D	120	92	12	18.000 / 17.957	69.00 / 68.69	65.030 / 65.011	255
	Reduced Dia.	F, J	G	82	54	11	16.000 / 15.957	59.00 / 58.71	55.030 / 55.011	230
	Inch *	N, B	P	4.72	4.19	-	.626 / .625	2.774 / 2.767	2.5 / 2.4993	10.04
	Inch Red. Dia. *	Q, T	R	3.23	2.75	-	.501 / .500	2.218 / 2.211	2.0 / 1.9993	9.06
A1602	Standard	C, E	D	135	105	13	20.000 / 19.948	79.50 / 79.19	75.030 / 75.011	295
	Reduced Dia.	F, J	G	105	82	12	18.000 / 17.957	69.00 / 68.69	65.030 / 65.011	275
	Inch *	N, B	P	5.31	4.63	-	.751 / .750	3.328 / 3.321	3.0 / 2.9993	11.61
	Inch Red. Dia. *	Q, T	R	4.13	3.70	-	.626 / .625	2.772 / 2.765	2.5 / 2.4993	10.83
A2002	Standard	C, E	D	170	135	15.5	25.000 / 24.948	95.00 / 94.59	90.035 / 90.013	355
	Reduced Dia.	F, J	G	130	103	14	22.000 / 21.948	85.00 / 84.69	80.030 / 80.011	310
	Inch *	N, B	P	6.69	5.94	-	.876 / .875	3.883 / 3.876	3.5 / 3.4993	13.98
	Inch Red. Dia. *	Q, T	R	5.12	4.63	-	.751 / .750	3.327 / 3.320	3.0 / 2.9993	12.30

* Inch shafts have an open ended keyway, therefore no 'C' dimension is required

ADDITIONAL FEATURES - COLUMN 20 ENTRY

COLUMN 20 ENTRY	DOUBLE OIL SEALS	PRIME PAINTED ONLY	HOLD BACK **	LUBRICANT TYPE * (See lubrication details - Page 9)	
				MINERAL	SYNTHETIC
-				•	
A	•			•	
B		•		•	
C			•	•	
D	•	•		•	
E		•	•	•	
F	•		•	•	
G	•	•	•	•	
H (1)					
J	•				
K		•			
L			•		
M	•	•			
N		•	•		
P	•		•		
Q	•	•	•		
R					•
S	•				•
T		•			•
U			•		•
V	•	•			•
W		•	•		•
X	•		•		•
Y	•	•	•		•

* Customer requests for special oils (food compatible etc) must be referred to our Applications Engineers, since a derate could result depending on oil type used.

(1) Standard option

** Direction of output shaft rotation should be specified, please see page 66.

SERIES AM

MOTOR PERFORMANCE DATA

ALUMINIUM FRAME MOTORS

Type Cage Rotor
Enclosure Rating IP55, TEHV (ICO141)
Supply S1 (Maximum Continuous)
Insulation Class 3 PH 50Hz 380 - 415V
Temp. Rise Class F
 B

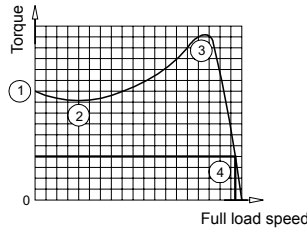

Typical Speed/Torque Curve (D.O.L. Stating)

- (1) Starting Torque or Locked Rotor Torque
- (2) Pull Up Torque or Run Up Torque
- (3) Pull Out Torque or Breakdown Torque
- (4) Full Load Torque

Torque/Speed curves for specific motors can be supplied on request

kW COLUMN ENTRY			MOTOR FRAME SIZE	FULL LOAD SPEED	FLC (AMPS) 400 VOLTS	EFFICIENCY %			POWER FACTOR			D.O.L. STARTING % OF FULL LOAD		STAR DELTA STARTING % OF FULL LOAD		PULL UP TORQUE % FLT	PULL OUT TORQUE % FLT	ROTOR INERTIA WK ² IN KGM2
15	16	17				FL	3/4 L	1/2 L	FL	3/4 L	1/2L	LRT	LRC	LRT	LRC			
.	1	2	63	1360	0.5	55	50	43	0.65	0.60	0.50	260	320			240	260	0.00025
.	1	2	63	835	0.6	43	41	37	0.62	0.56	0.46	230	250			200	180	0.0003
.	1	2	71	600	0.7	42	38	34	0.56	0.50	0.42	200	250			180	180	0.0006
.	1	8	63	2680	0.54	61	58	52	0.79	0.73	0.60	250	380			210	210	0.0002
.	1	8	63	1360	0.7	56	52	44	0.67	0.60	0.50	260	320			240	260	0.0003
.	1	8	71	840	0.8	52.5	51	47	0.62	0.55	0.47	230	260			200	180	0.0005
.	1	8	80	650	0.8	53	49	45	0.61	0.56	0.45	180	230			160	180	0.0024
.	2	5	63	2730	0.7	64	61	55	0.80	0.72	0.60	240	400			210	210	0.00023
.	2	5	71	1370	0.8	64	60	54	0.68	0.63	0.56	270	370			240	260	0.0005
.	2	5	71	845	1.1	53	52.5	50	0.62	0.55	0.47	240	280			200	180	0.0006
.	2	5	80	650	1.0	55.5	52	46	0.68	0.60	0.50	180	250			160	180	0.00275
.	3	7	71	2730	1.05	65	62	58	0.79	0.72	0.60	280	400			250	250	0.0004
.	3	7	71	1380	1.2	65	64	58	0.67	0.60	0.52	280	420			260	270	0.0006
.	3	7	80	925	1.2	62	59	50	0.72	0.62	0.52	220	340			170	200	0.0024
.	3	7	90	680	1.4	62	59	53	0.62	0.54	0.44	260	380			220	230	0.00375
.	5	5	71	2720	1.5	68	66	62	0.80	0.73	0.63	280	420			260	250	0.00045
.	5	5	80	1370	1.6	67.5	68	65	0.74	0.64	0.52	250	400			180	200	0.0013
.	5	5	80	925	1.65	67	62	53	0.72	0.62	0.52	250	370			200	210	0.00275
.	5	5	90	690	2.05	63	60	54	0.62	0.54	0.44	320	420			270	280	0.005
.	7	5	80	2800	1.9	71	69	67	0.83	0.78	0.66	230	460			190	230	0.00083
.	7	5	80	1385	2.2	70	69	66	0.72	0.62	0.51	250	430			190	200	0.0016
.	7	5	90	910	2.2	67	65	63	0.75	0.66	0.55	240	360			190	240	0.00375
.	7	5	100	700	2.4	68	68	66	0.68	0.58	0.48	160	440			110	170	0.0093
1	.	1	80	2840	2.5	76	75	73	0.83	0.75	0.64	250	540			190	240	0.00097
1	.	1	90	1380	2.9	72	72.5	72	0.76	0.68	0.57	250	440			220	250	0.0033
1	.	1	90	920	3.1	71	68	64	0.73	0.67	0.52	240	460			140	290	0.005
1	.	1	100	700	3.4	69	68	66	0.68	0.58	0.48	200	440			140	180	0.0123
1	.	5	90	2820	3.5	76	75	74	0.82	0.73	0.63	240	500			200	250	0.0016
1	.	5	90	1390	3.8	76	76	75	0.76	0.66	0.55	260	500			230	260	0.004
1	.	5	100	950	3.9	75	74.5	73	0.75	0.66	0.54	180	500			150	200	0.01
1	.	5	112	700	4.3	72	72	70	0.71	0.62	0.52	180	430			170	200	0.017
2	.	2	90	2850	5.0	78	78	77	0.82	0.73	0.63	300	700			260	320	0.0022
2	.	2	100	1410	5.2	78.5	78.5	78	0.78	0.71	0.60	240	530			210	240	0.0073
2	.	2	112	945	5.5	75	76	76	0.77	0.71	0.57	220	500			190	200	0.015
2	.	2	132	705	5.8	74	74	73.5	0.74	0.64	0.53	180	500			130	160	0.038
3	.	0	100	2900	6.5	79	79	77	0.84	0.74	0.64	270	700			250	300	0.005
3	.	0	100	1420	6.8	80	80	79	0.80	0.72	0.60	240	550			210	250	0.009
3	.	0	132	950	7.1	78	78	77	0.78	0.71	0.60	190	600			150	200	0.03
3	.	0	132	710	7.6	76.5	77	76	0.75	0.68	0.56	180	430			130	160	0.046
4	.	0	112	2900	8.2	83	83	82	0.85	0.81	0.73	280	700	85	220	260	300	0.0063
4	.	0	112	1425	8.6	83	83	82	0.81	0.72	0.62	270	620	84	195	230	290	0.0115
4	.	0	132	955	9.5	78	78	77	0.78	0.72	0.62	230	600	73	190	160	230	0.038
5	.	5	132	2900	11.8	83	82.5	80	0.82	0.75	0.64	340	700	100	220	280	280	0.016
5	.	5	132	1450	11.85	85	85.5	85	0.79	0.72	0.59	260	650	80	200	180	270	0.0238
5	.	5	132	960	13	81	80	79	0.76	0.66	0.54	260	660	80	210	180	260	0.046
7	.	5	132	2900	15.3	84.5	84	81	0.84	0.79	0.73	330	700	100	220	270	270	0.019
7	.	5	132	1450	15.6	86	86	85	0.81	0.75	0.64	260	690	80	215	180	270	0.03
9	.	2	132	2910	18.5	85	85	83	0.85	0.81	0.73	340	720	105	220	270	270	0.023
9	.	2	132	1460	18.5	88	88	87	0.82	0.75	0.65	260	740	81	230	180	270	0.0338
1	1	.	132	2920	22	89	89	88	0.82	0.77	0.68	210	620	70	200	200	270	0.03

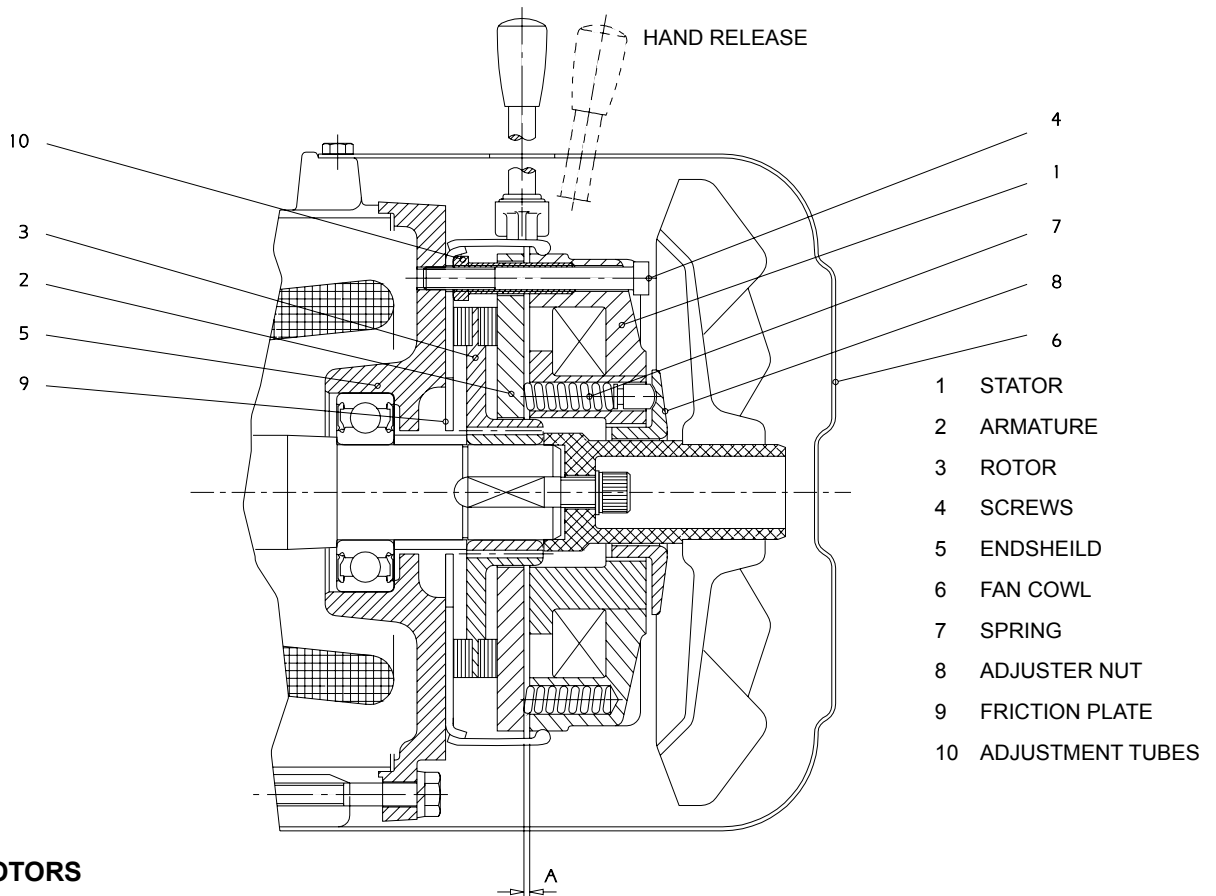

BRAKE MOTORS

Brake motors are fitted with spring-loaded brakes (mounted between motor endshield and fan blade) under the fan cowl. When the motor is switched on, the brake is supplied with DC voltage via a suitable rectifier.

The spring-loaded brake is normally off, electromagnetically released brake comprising the stator (1), the armature (2) and the brake rotor (3). It is fixed to the motor endshield (5) with screws (4) and located under the fan cowl (6). The friction plate (9) is held against the motor end shield (5) and serves as a counter friction face. When the release current does not flow the springs (7) press the armature (2) against the brake rotor (3) which in turn is pressed against the friction plate (9). The braking torque is generated through friction on both friction faces.

When switching on the motor the brake release coil is activated and the magnetic force of the stator (1) releases armature (2) against the spring resistance (7). The rotor (3) is freed.

The brake torque can be reduced by a maximum of 40% by using an adjuster (8).

We recommend to check the air gap A periodically, although, normally the brake needs no maintenance. Depending on the inertia to brake, speed, and switching frequency, the rotor can wear and become smaller due to the friction at the friction surfaces. If A max. (see table) is attained, the air gap must be adjusted. Where adjustment is needed, slacken screws (4) and reset the gap by turning adjustment tubes (10). Re-tighten screws (4) to the correct torque shown in the table below.

MOTOR FRAME SIZE		63	71	80	90	100/112	132
BRAKE SIZE		06	06	08	10	12	14
BRAKE TORQUE	Nm	2.85	4	8	16	32	60
A	mm	0.2	0.2	0.2	0.2	0.3	0.3
A max	mm	0.5	0.5	0.5	0.5	0.75	0.8
BOLT TIGHTENING TORQUE	Nm	3	3	6	10	10	25

MOTORS AVAILABLE
COLUMN 19 ENTRY

TYPE OF MOTOR	COLUMN 19 ENTRY
STANDARD	A
STANDARD WITH BRAKE	B
STANDARD WITH BRAKE & HAND RELEASE	C
FIT NON STANDARD MOTOR	N
FIT FREE ISSUE MOTOR	F

* The standard motor with brake will be fitted with a rectifier and wired for AC switching

For fast braking needed with safety critical applications (ie lifts, hoists and cranes), it is essential to switch the brake on the DC side of the rectifier.

In such cases motor type N should be entered in column 19.

For larger frame sizes standard proprietary brake motors are available. For details contact our Application Engineers

All variants of standard IEC and NEMA motors can be fitted to Series A, double reduction gear units.

For example:-

- Single phase
- DC
- Energy efficient
- Wash down
- Explosion-proof
- Suitable to be used with inverters
- Force vented
- Flame proof
- Two speed
- Tropicalised
- Crane duty
- Underground specification
- Fitted with encoders
- Fitted with tacho
- Fitted with thermistors
- Fitted with anti condensation heaters
- Hydraulic motors with IEC flanges
- Air motors with IEC flanges

Standard clutch brake modules with IEC flanges can be fitted between motor and gearhead.

Variable speed packages are available, either belt variators or mechanical disc variators.

For any of these combinations please contact your local Sales office.

B14 'C' FACE

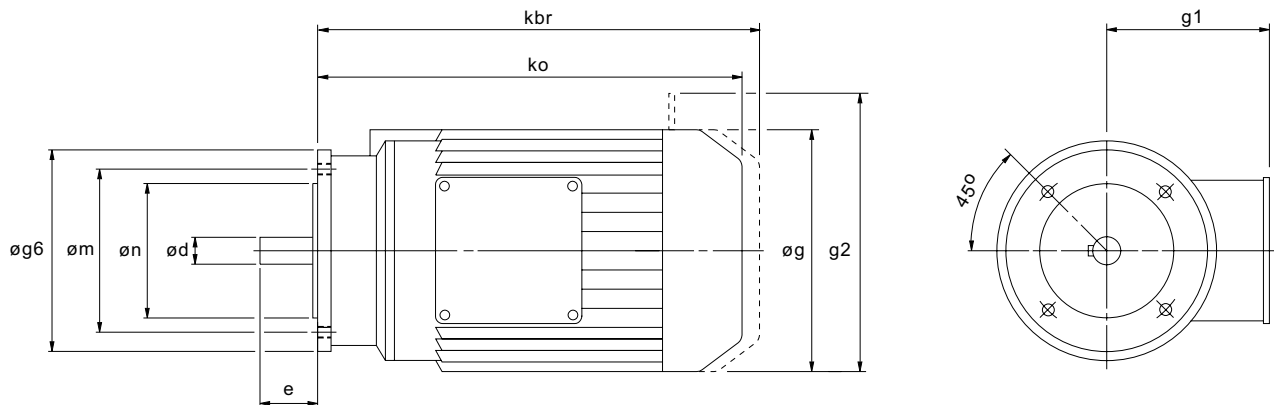

MOTOR FRAME SIZE	$\varnothing g_6$	$\varnothing m$	$\varnothing n$	$\varnothing d$	e	k_o	k_{br}	$\varnothing g$	g_1	g_2	FIXING BOLTS
71	105	85	70	14	30	210	251	137	107	167	4-M6
80	120	100	80	19	40	230	280	158	118	190	4-M6
90S/L	140	115	95	24	50	270	329	177	149	218	4-M8
100	160	130	110	28	60	340	408	197	159	238	4-M8
112	160	130	110	28	60	340	408	197	159	238	4-M8
132S/M	200	165	130	38	80	402	473	253	184	288	4-M10

B5 'D' FACE

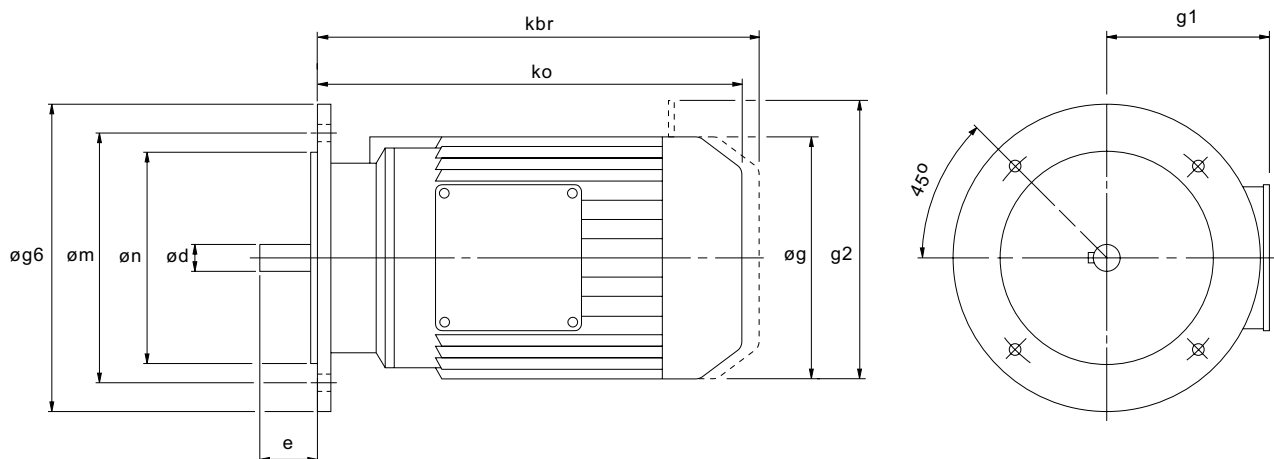

MOTOR FRAME SIZE	$\varnothing g_6$	$\varnothing m$	$\varnothing n$	$\varnothing d$	e	k_o	k_{br}	$\varnothing g$	g_1	g_2	FIXING BOLTS
63	140	115	95	11	23	185	227	122	101	160	4-M8
71	160	130	110	14	30	210	251	137	107	167	4-M8
80	200	165	130	19	40	230	280	158	118	190	4-M10
90S/L	200	165	130	24	50	270	329	177	149	218	4-M10
100	250	215	180	28	60	340	408	197	159	238	4-M12
112	250	215	180	28	60	340	408	197	159	238	4-M12
132S/M	300	265	230	38	80	402	473	253	184	288	4-M12

These dimensions apply to our standard motors

IEC MOTOR ADAPTORS, COLUMN 12 ENTRY FOR G TYPE ONLY
(DOUBLE REDUCTION ONLY)

MOTOR FRAME / FLANGE	UNIT SIZE			
	1002	1252	1602	2002
80/D	A	G	-	-
80/C	B	H	-	-
90/D	C	J	N	-
90/C	D	K	P	-
100/112/D	E	L	Q	U
100/112/C	F	M	R	-
132/D	-	W	S	V
132/C	-	-	T	-

NEMA MOTOR ADAPTORS, COLUMN 12 ENTRY FOR A TYPE ONLY
(DOUBLE REDUCTION ONLY)

MOTOR FRAME / FLANGE	UNIT SIZE			
	1002	1252	1602	2002
56C	A	-	-	-
143TC/145TC	B	D	F	J
182TC/184TC	C	E	G	K
213TC/215TC	-	-	H	L
254TC/256TC	-	-	-	M

NOTE

Close coupled motorised units are only available in double reduction versions ie ratios 75:1 to 4200:1.
 For motorised units up to 75:1 use our Series C product range.

Maximum permissible overhung loads

When a sprocket, gear etc. is mounted on the shaft a calculation, as below, must be made to determine the overhung load on the shaft, and the results compared to the maximum permissible overhung loads tabulated. Overhung loads can be reduced by increasing the diameter to the sprocket, gear, etc. If the maximum permissible overhung load is exceeded, the sprocket, gear, etc. should be mounted on a separate shaft, flexibly coupled and supported in its own bearings, or the gear unit shaft should be extended to run in an outboard bearing. Alternatively, a larger gear is often a less expensive solution.

Permissible overhung loads vary according to the direction of rotation. The values tabulated are for the most unfavourable direction with the unit transmitting full rated power and the load P applied midway along the shaft extension. Hence they can sometimes be increased for a more favourable direction of rotation, or if the power transmitted is less than the rated capacity of the gear unit, or if the load is applied nearer to the gear unit case. Refer to our Applications Engineers for further details. In any event, the sprocket, gear etc. should be positioned as close as possible to the gear unit case in order to reduce bearing loads and shaft stresses, and to prolong life.

Overhung load (Newtons)

$$P = \frac{\text{kW} \times 9,500,000 \times K}{N \times R}$$

where

- P = equivalent overhung load (Newtons)
- kW = power transmitted by the shaft (kilowatts)
- N = speed of shaft (rpm)
- R = pitch radius of sprocket, etc. (mm)
- K = factor

Note: 1 Newton = 0.10197 kg = 0.2248 lbs.

Overhung member	K (factor)
Chain sprocket*	1.00
Spur or helical pinion	1.25
Vee belt sheave	1.50
Flat belt pulley	2.00

* If multistrand chain drives are equally loaded and the outer strand is further than dimension A output or B input refer to our Applications Engineers.

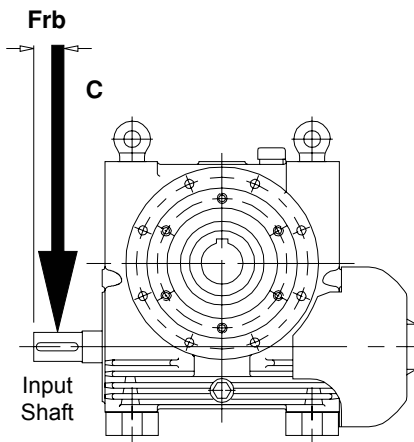

**Single reduction
(worm)**

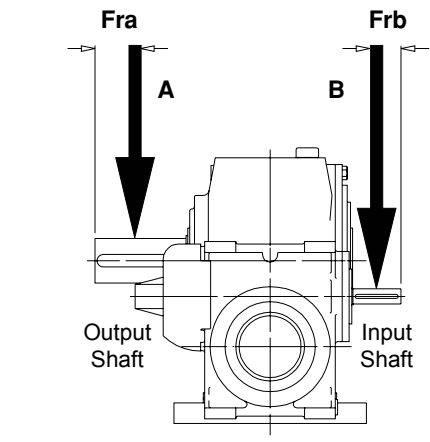
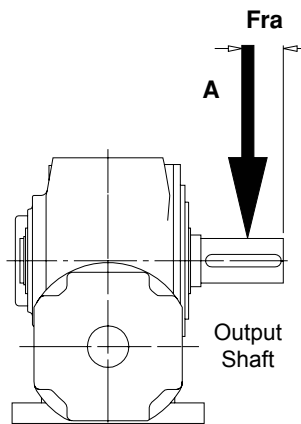

**Double reduction
(worm/worm)**

Distance midway along the shaft extension

Size of Unit	Dimension A (mm)	Dimension B (mm)	Dimension C (mm)
1002	55	28.5	29
1252	60	35	41
1602	67.5	41.5	41
2002	85	29	41

SERIES AM

OVERHUNG LOADS (NEWTONS) & AXIAL THRUSTS (NEWTON)

OVERHUNG LOADS (Fra) & AXIAL THRUST CAPACITIES ON OUTPUTSHAFT

		OUTPUT RPM						
		580	290	190	145	95	70	15 & UNDER
A1002	OHL (Fra)	14300	15400	16300	18000	18900	18900	18800
	THRUST	13600	13600	13600	13600	13600	13600	13600
A1252	OHL (Fra)	19300	20500	21600	24300	25000	25000	25000
	THRUST	17300	17300	17300	17300	17300	17300	17300
A1602	OHL (Fra)	27200	28500	30700	34500	37400	41600	41600
	THRUST	19900	19900	19900	19900	19900	19900	19900
A2002 (REDUCER)	OHL (Fra)	32400	33500	35700	42100	44800	45200	45100
	THRUST	20100	20100	20100	20100	20100	20100	20100
A2002 (MOTORISED)	OHL (Fra)						45200	45200
	THRUST						20100	20100

REDUCER OVERHUNG LOADS (Frb) ON INPUTSHAFT

AT 1450rpm

		RATIO	SIZE			
			A1002	A1252	A1602	A2002
SINGLE REDUCTION UNIT	5	6930	7130	11400	15400	
	7.5	7140	7660	12000	15800	
	10	7230	7660	11700	15400	
	12.5	7350	7730	11300	14500	
	15	6890	8060	9950	13200	
	20	7600	7860	8840	11300	
	25	4920	7510	10300	12400	
	30	6210	7380	8970	9820	
	40	6350	9710	8160	8370	
	50	5500	7120	8190	12600	
	60	5010	5670	9590	13600	
DOUBLE REDUCTION UNIT	70	6920	4940	9860	12000	
	100	1580	2900	2930	7810	
	150	1280	1500	2130	7770	
	200	1560	1530	2510	8080	
	300	1170	1540	1320	8050	
	400	1420	1600	1690	8170	
	600	1460	1680	1980	8170	
	800	1690	1730	2290	8190	
	1200	1710	1780	2580	8220	
	1600	1750	1990	2750	8220	
	2400	1320	1940	2140	6300	
	3000	1400	1950	2290	6440	
	4200	1540	2050	2790	8080	

	NOMINAL RATIO	NOMINAL OUTPUT SPEED REV / MIN	CAPACITY		SIZE OF UNIT				
					A1002	A1252	A1602	A2002	
SINGLE REDUCTION	5.0	580.00	Mechanical	Input Power kW	25.70	44.30	82.30	140.00	
				Output Torque Nm	416.	716.	1340.	2270.	
			Thermal	Input Power kW	42.80	65.10	97.90	162.00	
				Output Torque Nm	696.	1060.	1590.	2630.	
					Efficiency %	96	96	96	97
	7.5	386.67	Mechanical	Input Power kW	20.80	36.50	62.70	111.00	
				Output Torque Nm	477.	843.	1490.	2640.	
			Thermal	Input Power kW	32.60	50.30	81.40	141.00	
				Output Torque Nm	755.	1170.	1940.	3370.	
					Efficiency %	94	95	95	95
	10.0	290.00	Mechanical	Input Power kW	17.20	30.60	55.60	97.40	
				Output Torque Nm	518.	924.	1700.	2980.	
			Thermal	Input Power kW	29.30	44.40	71.40	124.00	
				Output Torque Nm	888.	1350.	2190.	3800.	
					Efficiency %	94	94	95	95
	12.5	232.00	Mechanical	Input Power kW	15.00	26.70	47.80	85.20	
				Output Torque Nm	562.	1010.	1810.	3240.	
			Thermal	Input Power kW	24.90	37.70	63.30	111.00	
				Output Torque Nm	943.	1430.	2410.	4220.	
					Efficiency %	92	93	94	94
	15.0	193.33	Mechanical	Input Power kW	13.90	24.80	44.20	74.90	
				Output Torque Nm	645.	1170.	1990.	3530.	
			Thermal	Input Power kW	20.20	33.30	53.90	97.40	
				Output Torque Nm	945.	1580.	2430.	4610.	
					Efficiency %	91	92	93	93
	20.0	145.00	Mechanical	Input Power kW	10.90	19.80	34.90	62.50	
				Output Torque Nm	627.	1150.	2140.	3870.	
			Thermal	Input Power kW	18.50	28.10	39.40	75.50	
				Output Torque Nm	1080.	1650.	2420.	4690.	
					Efficiency %	90	90	91	92
	25.0	116.00	Mechanical	Input Power kW	12.30	20.30	27.90	51.80	
				Output Torque Nm	889.	1480.	2010.	3780.	
			Thermal	Input Power kW	13.70	21.90	35.70	65.50	
				Output Torque Nm	988.	1600.	2590.	4810.	
					Efficiency %	88	89	89	90
	30.0	96.67	Mechanical	Input Power kW	9.39	17.50	31.40	60.50	
Output Torque Nm				796.	1500.	2710.	5310.		
Thermal			Input Power kW	12.50	19.00	27.50	51.80		
			Output Torque Nm	1070.	1630.	2360.	4530.		
				Efficiency %	86	87	87	89	
40.0	72.50	Mechanical	Input Power kW	6.79	11.70	22.40	41.80		
			Output Torque Nm	732.	1290.	2480.	4750.		
		Thermal	Input Power kW	9.99	16.40	23.10	43.90		
			Output Torque Nm	1100.	1830.	2560.	5010.		
				Efficiency %	82	84	84	86	
50.0	58.00	Mechanical	Input Power kW	5.32	9.53	17.50	30.50		
			Output Torque Nm	692.	1270.	2350.	4200.		
		Thermal	Input Power kW	8.70	13.60	20.60	35.60		
			Output Torque Nm	1160.	1850.	2790.	4940.		
				Efficiency %	79	81	82	84	
60.0	48.33	Mechanical	Input Power kW	4.19	7.13	13.60	23.60		
			Output Torque Nm	625.	1090.	2120.	3780.		
		Thermal	Input Power kW	7.28	11.50	16.70	29.30		
			Output Torque Nm	1130.	1820.	2630.	4770.		
				Efficiency %	75	77	79	81	
70.0	41.43	Mechanical	Input Power kW	3.60	5.70	11.60	19.10		
			Output Torque Nm	593.	979.	2010.	3450.		
		Thermal	Input Power kW	5.96	9.98	13.40	25.40		
			Output Torque Nm	1030.	1800.	2350.	4710.		
				Efficiency %	71	75	75	78	

Only suitable for mounting positions 1, 3 and 4

For mounting positions 2, 5 and 6 refer to our Application Engineers

SERIES AM

RATINGS AT 2900 RPM INPUT

	NOMINAL RATIO	NOMINAL OUTPUT SPEED REV / MIN	CAPACITY		SIZE OF UNIT				
					A1002	A1252	A1602	A2002 Reducer	A2002 Motorised
DOUBLE REDUCTION	75.0	38.67	Mechanical	Input Power kW	5.75	7.89	18.30	25.60	19.80
				Output Torque Nm	1190.	1750.	3690.	5860.	4260.
				Efficiency %	81	84	86	88	84
			Thermal	Input Power kW	5.66	9.08	15.50	28.00	18.30
				Output Torque Nm	1170.	2020.	3110.	6400.	3930.
				Efficiency %	79	81	83	86	83
	100.	29.00	Mechanical	Input Power kW	3.68	7.11	14.40	21.80	19.80
				Output Torque Nm	930.	1930.	3910.	6490.	5270.
				Efficiency %	79	81	83	86	83
			Thermal	Input Power kW	5.17	7.71	11.50	21.90	16.30
				Output Torque Nm	1320.	2100.	3120.	6530.	4290.
				Efficiency %	79	81	83	86	83
	125.	23.20	Mechanical	Input Power kW	4.43	6.63	11.40	17.80	15.50
				Output Torque Nm	1380.	2220.	3630.	6230.	5170.
				Efficiency %	75	78	81	84	84
			Thermal	Input Power kW	3.95	6.15	10.40	19.50	15.40
				Output Torque Nm	1220.	2050.	3290.	6840.	5120.
				Efficiency %	75	78	81	84	84
	150.	19.33	Mechanical	Input Power kW	3.76	4.72	11.00	15.80	11.70
				Output Torque Nm	1410.	1960.	4230.	6600.	4910.
				Efficiency %	75	79	82	85	84
			Thermal	Input Power kW	3.60	5.58	9.56	16.60	15.10
				Output Torque Nm	1340.	2330.	3650.	6910.	6400.
				Efficiency %	75	79	82	85	84
	200.	14.50	Mechanical	Input Power kW	2.30	4.28	9.47	13.40	13.60
				Output Torque Nm	1040.	2170.	4850.	7220.	6710.
				Efficiency %	73	76	78	82	76
			Thermal	Input Power kW	3.32	4.78	7.21	13.10	10.30
				Output Torque Nm	1530.	2440.	3650.	7050.	4970.
				Efficiency %	73	76	78	82	76
	225.	12.89	Mechanical	Input Power kW	2.83	3.77	9.38	11.30	12.60
				Output Torque Nm	1530.	2090.	5180.	7210.	7390.
				Efficiency %	71	75	78	82	82
			Thermal	Input Power kW	2.82	4.88	7.95	13.20	12.40
				Output Torque Nm	1530.	2750.	4370.	8410.	7260.
				Efficiency %	71	75	78	82	82
	250.	11.60	Mechanical	Input Power kW	2.93	4.96	7.15	12.20	11.70
				Output Torque Nm	1580.	2880.	4280.	7840.	7760.
				Efficiency %	64	72	74	80	82
			Thermal	Input Power kW	1.79	5.43	8.66	13.70	12.00
				Output Torque Nm	924.	3160.	5220.	8790.	7960.
				Efficiency %	64	72	74	80	82
	300.	9.67	Mechanical	Input Power kW	2.43	3.05	7.49	9.54	9.58
				Output Torque Nm	1610.	2200.	5390.	7490.	7270.
				Efficiency %	64	72	76	80	76
			Thermal	Input Power kW	1.99	4.38	7.06	11.90	8.69
				Output Torque Nm	1290.	3220.	5070.	9400.	6560.
				Efficiency %	64	72	76	80	76
350.	8.29	Mechanical	Input Power kW	1.14	1.96	4.14	6.31	8.90	
			Output Torque Nm	718.	1420.	2940.	5180.	7400.	
			Efficiency %	55	60	64	69	76	
		Thermal	Input Power kW	1.98	3.13	4.59	8.16	8.46	
			Output Torque Nm	1340.	2390.	3280.	6820.	7010.	
			Efficiency %	55	60	64	69	76	
375.	7.73	Mechanical	Input Power kW	2.11	2.70	6.73	8.06	8.27	
			Output Torque Nm	1670.	2290.	5790.	7780.	7760.	
			Efficiency %	61	66	71	76	76	
		Thermal	Input Power kW	1.79	4.24	6.75	11.00	10.60	
			Output Torque Nm	1390.	3720.	5820.	10700.	10100.	
			Efficiency %	61	66	71	76	76	
400.	7.25	Mechanical	Input Power kW	1.52	2.79	6.07	8.15	7.92	
			Output Torque Nm	1190.	2440.	5750.	8210.	6800.	
			Efficiency %	61	70	72	77	64	
		Thermal	Input Power kW	1.99	3.78	5.37	9.48	6.51	
			Output Torque Nm	1600.	3370.	5070.	9600.	5430.	
			Efficiency %	61	70	72	77	64	
450.	6.44	Mechanical	Input Power kW	1.60	3.09	6.23	7.78	7.23	
			Output Torque Nm	1450.	2940.	6130.	8640.	7760.	
			Efficiency %	61	66	68	72	75	
		Thermal	Input Power kW	2.06	3.01	4.43	7.54	7.89	
			Output Torque Nm	1900.	2860.	4290.	8350.	8500.	
			Efficiency %	61	66	68	72	75	
500.	5.80	Mechanical	Input Power kW	1.85	2.65	4.74	6.73	6.54	
			Output Torque Nm	1770.	2810.	5210.	7890.	7930.	
			Efficiency %	58	66	70	75	75	
		Thermal	Input Power kW	1.99	3.06	4.91	8.55	7.65	
			Output Torque Nm	1910.	3280.	5410.	10100.	9340.	
			Efficiency %	58	66	70	75	75	
600.	4.83	Mechanical	Input Power kW	1.53	1.89	4.66	5.57	3.44	
			Output Torque Nm	1720.	2360.	5980.	8030.	5070.	
			Efficiency %	55	61	66	71	78	
		Thermal	Input Power kW	1.46	3.95	6.19	9.86	5.39	
			Output Torque Nm	1630.	5220.	8050.	14500.	8000.	
			Efficiency %	55	61	66	71	78	
625.	4.64	Mechanical	Input Power kW	1.62	2.36	4.09	5.71	5.93	
			Output Torque Nm	1830.	2930.	5300.	8210.	8190.	
			Efficiency %	55	60	64	71	70	
		Thermal	Input Power kW	1.79	2.99	4.74	7.75	7.71	
			Output Torque Nm	2050.	3790.	6210.	11300.	10900.	
			Efficiency %	55	60	64	71	70	
700.	4.14	Mechanical	Input Power kW	1.02	1.55	2.42	3.46	5.19	
			Output Torque Nm	1120.	1940.	3210.	5080.	7510.	
			Efficiency %	45	56	59	65	65	
		Thermal	Input Power kW	0.70	2.37	3.96	5.47	5.32	
			Output Torque Nm	707.	3110.	5480.	8240.	7720.	
			Efficiency %	45	56	59	65	65	
750.	3.87	Mechanical	Input Power kW	1.31	1.58	3.56	4.60	4.16	
			Output Torque Nm	1720.	2360.	5410.	8000.	8000.	
			Efficiency %	50	59	63	69	76	
		Thermal	Input Power kW	1.05	3.86	6.15	8.03	7.48	
			Output Torque Nm	1340.	6190.	9610.	14300.	14500.	
			Efficiency %	50	59	63	69	76	
800.	3.63	Mechanical	Input Power kW	0.97	1.74	3.68	4.71	4.86	
			Output Torque Nm	1270.	2620.	6130.	8640.	8640.	
			Efficiency %	51	59	62	68	67	
		Thermal	Input Power kW	1.46	3.43	4.75	7.78	5.36	
			Output Torque Nm	2010.	5480.	8040.	14600.	9590.	
			Efficiency %	51	59	62	68	67	

For mounting positions 4 (primary unit) refer to our Application Engineers

SERIES AM

RATINGS AT 2900 RPM INPUT

	NOMINAL RATIO	NOMINAL OUTPUT SPEED REV / MIN	CAPACITY		SIZE OF UNIT				
					A1002	A1252	A1602	A2002 Reducer	A2002 Motorised
DOUBLE REDUCTION	900.	3.22	Mechanical	Input Power kW	1.14	1.40	2.88	3.97	4.22
				Output Torque Nm	1710.	2350.	4990.	7990.	7880.
				Efficiency %	47	55	60	66	64
			Thermal	Input Power kW	0.91	3.10	5.17	6.74	4.97
				Output Torque Nm	1320.	5630.	9290.	13900.	9380.
				Efficiency %	47	55	60	66	64
	1000.	2.90	Mechanical	Input Power kW	1.19	1.67	2.87	3.99	3.82
				Output Torque Nm	1890.	3030.	5460.	8480.	8050.
				Efficiency %	48	55	59	66	64
			Thermal	Input Power kW	1.46	2.80	4.22	6.57	4.83
				Output Torque Nm	2390.	5320.	8280.	14300.	10300.
				Efficiency %	48	55	59	66	64
	1200.	2.42	Mechanical	Input Power kW	0.91	1.61	2.83	3.56	3.03
				Output Torque Nm	1630.	3330.	6130.	8640.	7240.
				Efficiency %	45	52	55	61	60
			Thermal	Input Power kW	1.46	2.51	3.56	5.76	4.18
				Output Torque Nm	2790.	5440.	7870.	14400.	10200.
				Efficiency %	45	52	55	61	60
	1250.	2.32	Mechanical	Input Power kW	1.02	1.40	2.45	3.32	2.97
				Output Torque Nm	1890.	3020.	5530.	8460.	8460.
				Efficiency %	45	52	56	63	71
			Thermal	Input Power kW	1.05	2.77	4.02	6.24	5.69
				Output Torque Nm	1950.	6390.	9460.	16500.	16500.
				Efficiency %	45	52	56	63	71
	1400.	2.07	Mechanical	Input Power kW	0.69	1.18	2.42	3.07	3.32
				Output Torque Nm	1260.	2610.	6040.	8640.	8440.
				Efficiency %	41	49	53	60	57
			Thermal	Input Power kW	0.70	2.37	3.96	5.47	4.57
				Output Torque Nm	1300.	5720.	10300.	15900.	12100.
				Efficiency %	41	49	53	60	57
	1500.	1.93	Mechanical	Input Power kW	0.90	1.25	2.16	2.88	2.65
				Output Torque Nm	1890.	3020.	5580.	8440.	8640.
				Efficiency %	43	49	53	61	66
			Thermal	Input Power kW	0.91	2.82	3.93	6.00	5.16
				Output Torque Nm	1920.	7420.	10700.	18400.	17100.
				Efficiency %	43	49	53	61	66
	1600.	1.81	Mechanical	Input Power kW	0.82	1.07	2.30	2.84	2.74
				Output Torque Nm	1770.	2650.	6130.	8640.	8620.
				Efficiency %	41	47	51	58	62
			Thermal	Input Power kW	1.46	2.24	3.05	4.74	4.05
				Output Torque Nm	3440.	6120.	8360.	14900.	13000.
				Efficiency %	41	47	51	58	62
1750.	1.66	Mechanical	Input Power kW	0.83	1.14	1.98	2.61	2.68	
			Output Torque Nm	1890.	3010.	5620.	8430.	7590.	
			Efficiency %	38	46	50	57	53	
		Thermal	Input Power kW	0.70	2.37	3.89	5.47	3.91	
			Output Torque Nm	1530.	6870.	11800.	18600.	11700.	
			Efficiency %	38	46	50	57	53	
1800.	1.61	Mechanical	Input Power kW	0.70	1.21	2.10	2.60	2.35	
			Output Torque Nm	1620.	3320.	6130.	8640.	8640.	
			Efficiency %	39	46	49	56	63	
		Thermal	Input Power kW	0.91	2.53	3.56	5.46	4.21	
			Output Torque Nm	2240.	7600.	10900.	19100.	15800.	
			Efficiency %	39	46	49	56	63	
2000.	1.45	Mechanical	Input Power kW	0.72	0.91	1.95	2.39	2.33	
			Output Torque Nm	1770.	2640.	6130.	8640.	8620.	
			Efficiency %	38	44	48	55	56	
		Thermal	Input Power kW	1.05	2.13	2.92	4.51	3.86	
			Output Torque Nm	2810.	7050.	9560.	17200.	15000.	
			Efficiency %	38	44	48	55	56	
2100.	1.38	Mechanical	Input Power kW	0.65	1.11	1.91	2.36	1.97	
			Output Torque Nm	1620.	3320.	6130.	8640.	8640.	
			Efficiency %	36	43	46	53	64	
		Thermal	Input Power kW	0.70	2.37	3.56	5.40	4.66	
			Output Torque Nm	1790.	7890.	12100.	21000.	20800.	
			Efficiency %	36	43	46	53	64	
2400.	1.21	Mechanical	Input Power kW	0.63	0.82	1.72	2.09	1.81	
			Output Torque Nm	1770.	2640.	6130.	8640.	8640.	
			Efficiency %	35	41	45	52	64	
		Thermal	Input Power kW	0.91	2.11	2.84	4.36	4.53	
			Output Torque Nm	2750.	7940.	10700.	19200.	22000.	
			Efficiency %	35	41	45	52	64	
2500.	1.16	Mechanical	Input Power kW	0.52	0.79	1.55	2.03	1.76	
			Output Torque Nm	1370.	2600.	5640.	8610.	8610.	
			Efficiency %	32	40	44	52	60	
		Thermal	Input Power kW	1.05	1.76	2.54	3.78	3.39	
			Output Torque Nm	3350.	6690.	9820.	17000.	17000.	
			Efficiency %	32	40	44	52	60	
2800.	1.04	Mechanical	Input Power kW	0.59	0.76	1.58	1.90	1.77	
			Output Torque Nm	1760.	2640.	6130.	8640.	8610.	
			Efficiency %	32	38	42	49	55	
		Thermal	Input Power kW	0.70	2.12	2.84	4.32	3.47	
			Output Torque Nm	2190.	8860.	11900.	21100.	17800.	
			Efficiency %	32	38	42	49	55	
3000.	0.97	Mechanical	Input Power kW	0.46	0.72	1.39	1.78	1.39	
			Output Torque Nm	1380.	2600.	5690.	8600.	7740.	
			Efficiency %	30	37	41	49	56	
		Thermal	Input Power kW	0.91	1.74	2.47	3.65	2.85	
			Output Torque Nm	3290.	7530.	11000.	19000.	16300.	
			Efficiency %	30	37	41	49	56	
3500.	0.83	Mechanical	Input Power kW	0.44	0.67	1.29	1.62	1.08	
			Output Torque Nm	1400.	2590.	5750.	8590.	6600.	
			Efficiency %	27	34	39	46	53	
		Thermal	Input Power kW	0.70	1.73	2.45	3.62	2.53	
			Output Torque Nm	2610.	8330.	12100.	20900.	16200.	
			Efficiency %	27	34	39	46	53	
3600.	0.81	Mechanical	Input Power kW	0.36	0.55	1.00	1.44	1.30	
			Output Torque Nm	1060.	2070.	4330.	7730.	8590.	
			Efficiency %	25	32	37	45	58	
		Thermal	Input Power kW	0.91	1.53	2.10	3.09	3.07	
			Output Torque Nm	3720.	7490.	10400.	18300.	20700.	
			Efficiency %	25	32	37	45	58	
4200.	0.69	Mechanical	Input Power kW	0.35	0.52	0.94	1.32	1.03	
			Output Torque Nm	1070.	2090.	4380.	7730.	7730.	
			Efficiency %	22	29	34	42	55	
		Thermal	Input Power kW	0.70	1.52	2.08	3.06	2.57	
			Output Torque Nm	2960.	8280.	11400.	20100.	19900.	
			Efficiency %	22	29	34	42	55	

	NOMINAL RATIO	NOMINAL OUTPUT SPEED REV / MIN	CAPACITY		SIZE OF UNIT			
					A1002	A1252	A1602	A2002
SINGLE REDUCTION	5.0	350.00	Mechanical	Input Power kW	19.80	34.20	63.70	109.00
				Output Torque Nm	531.	917.	1720.	2930.
			Thermal	Input Power kW	28.50	45.00	70.40	119.00
				Output Torque Nm	767.	1210.	1900.	3200.
		Efficiency %	96	96	97	97		
	7.5	233.33	Mechanical	Input Power kW	15.80	27.90	48.00	85.10
				Output Torque Nm	603.	1070.	1890.	3370.
			Thermal	Input Power kW	21.60	34.00	56.10	98.40
				Output Torque Nm	824.	1300.	2210.	3890.
		Efficiency %	95	95	95	96		
	10.0	175.00	Mechanical	Input Power kW	13.00	23.20	42.20	74.10
				Output Torque Nm	648.	1160.	2140.	3770.
			Thermal	Input Power kW	19.20	29.80	48.90	86.00
				Output Torque Nm	959.	1490.	2480.	4380.
		Efficiency %	94	94	95	95		
	12.5	140.00	Mechanical	Input Power kW	11.20	20.10	36.00	64.20
				Output Torque Nm	698.	1260.	2260.	4050.
			Thermal	Input Power kW	16.20	25.20	43.20	76.50
				Output Torque Nm	1010.	1580.	2720.	4840.
		Efficiency %	93	93	94	94		
	15.0	116.67	Mechanical	Input Power kW	10.30	17.20	33.10	56.00
				Output Torque Nm	795.	1340.	2470.	4390.
			Thermal	Input Power kW	13.20	22.20	36.80	67.00
				Output Torque Nm	1020.	1730.	2750.	5260.
		Efficiency %	91	92	93	94		
	20.0	87.50	Mechanical	Input Power kW	7.56	14.60	25.90	46.40
				Output Torque Nm	720.	1410.	2630.	4770.
			Thermal	Input Power kW	12.00	18.60	27.00	52.00
				Output Torque Nm	1150.	1800.	2740.	5350.
		Efficiency %	90	91	91	92		
	25.0	70.00	Mechanical	Input Power kW	8.97	14.10	20.60	38.30
				Output Torque Nm	1070.	1700.	2460.	4640.
Thermal			Input Power kW	8.95	14.60	24.30	46.40	
			Output Torque Nm	1060.	1760.	2920.	5650.	
	Efficiency %	87	88	89	91			
30.0	58.33	Mechanical	Input Power kW	6.55	12.90	23.30	44.80	
			Output Torque Nm	916.	1820.	3320.	6520.	
		Thermal	Input Power kW	8.16	12.60	18.90	35.80	
			Output Torque Nm	1150.	1790.	2680.	5190.	
	Efficiency %	85	87	87	89			
40.0	43.75	Mechanical	Input Power kW	4.98	8.15	16.50	29.30	
			Output Torque Nm	887.	1490.	3030.	5530.	
		Thermal	Input Power kW	6.52	10.80	15.80	30.60	
			Output Torque Nm	1170.	1990.	2900.	5780.	
	Efficiency %	82	84	84	86			
50.0	35.00	Mechanical	Input Power kW	3.76	6.63	12.80	21.10	
			Output Torque Nm	808.	1460.	2860.	4830.	
		Thermal	Input Power kW	5.80	9.27	14.10	25.40	
			Output Torque Nm	1270.	2060.	3160.	5850.	
	Efficiency %	79	81	82	84			
60.0	29.17	Mechanical	Input Power kW	3.11	4.94	10.20	16.20	
			Output Torque Nm	773.	1260.	2640.	4340.	
		Thermal	Input Power kW	4.91	7.85	11.80	20.90	
			Output Torque Nm	1240.	2040.	3080.	5640.	
	Efficiency %	76	78	79	82			
70.0	25.00	Mechanical	Input Power kW	2.37	3.93	8.91	13.10	
			Output Torque Nm	645.	1130.	2570.	3970.	
		Thermal	Input Power kW	4.03	6.81	9.48	18.00	
			Output Torque Nm	1130.	2010.	2740.	5550.	
	Efficiency %	71	75	76	79			

For mounting positions 5 and 6 (speed limit) refer to our Application Engineers

SERIES AM

RATINGS AT 1750 RPM INPUT

	NOMINAL RATIO	NOMINAL OUTPUT SPEED REV / MIN	CAPACITY		SIZE OF UNIT				
					A1002	A1252	A1602	A2002 Reducer	A2002 Motorised
DOUBLE REDUCTION	75.0	23.33	Mechanical	Input Power kW	4.13	5.30	13.40	17.40	14.90
				Output Torque Nm	1370.	1900.	4370.	6470.	5310.
				Efficiency %	79	82	84	86	84
			Thermal	Input Power kW	3.88	6.12	10.80	18.10	15.00
				Output Torque Nm	1290.	2200.	3510.	6740.	5350.
				Efficiency %	76	80	81	84	83
	100.	17.50	Mechanical	Input Power kW	2.49	4.79	10.50	14.60	14.90
				Output Torque Nm	1010.	2110.	4590.	7070.	6560.
				Efficiency %	76	80	81	84	83
			Thermal	Input Power kW	3.56	5.22	8.07	14.20	13.40
				Output Torque Nm	1470.	2300.	3520.	6870.	5880.
				Efficiency %	76	80	81	84	83
	125.	14.00	Mechanical	Input Power kW	3.04	4.50	8.26	12.00	11.60
				Output Torque Nm	1510.	2420.	4240.	6800.	6320.
				Efficiency %	73	76	79	82	83
			Thermal	Input Power kW	2.72	4.17	7.29	12.70	13.30
				Output Torque Nm	1350.	2240.	3730.	7220.	7290.
				Efficiency %	73	76	79	82	83
	150.	11.67	Mechanical	Input Power kW	2.58	3.20	6.37	10.70	8.61
				Output Torque Nm	1550.	2150.	5200.	7260.	5890.
				Efficiency %	73	77	80	83	82
			Thermal	Input Power kW	2.87	4.41	7.40	12.60	10.20
				Output Torque Nm	1730.	3000.	4580.	8570.	6970.
				Efficiency %	71	75	76	80	77
	200.	8.75	Mechanical	Input Power kW	1.57	2.91	6.68	9.11	9.06
				Output Torque Nm	1140.	2390.	5500.	7950.	7360.
				Efficiency %	71	75	76	80	77
			Thermal	Input Power kW	2.66	3.79	5.59	10.00	8.47
				Output Torque Nm	1980.	3140.	4580.	8750.	6860.
				Efficiency %	71	75	76	80	77
	225.	7.78	Mechanical	Input Power kW	1.93	2.53	6.47	7.58	9.06
				Output Torque Nm	1660.	2270.	5760.	7810.	8640.
				Efficiency %	68	73	77	79	81
			Thermal	Input Power kW	2.45	3.98	6.39	10.50	11.00
				Output Torque Nm	2140.	3630.	5690.	10900.	10500.
				Efficiency %	68	73	77	79	81
	250.	7.00	Mechanical	Input Power kW	1.93	3.45	4.88	8.31	8.02
				Output Torque Nm	1650.	3210.	4700.	8640.	8640.
				Efficiency %	63	70	72	78	80
			Thermal	Input Power kW	1.58	4.63	6.75	8.95	10.20
				Output Torque Nm	1330.	4360.	6550.	9300.	11000.
				Efficiency %	63	70	72	78	80
	300.	5.83	Mechanical	Input Power kW	1.64	2.03	5.18	6.32	6.43
				Output Torque Nm	1720.	2370.	5990.	8050.	7950.
				Efficiency %	62	71	74	78	75
			Thermal	Input Power kW	1.77	3.70	5.86	9.71	7.59
				Output Torque Nm	1870.	4400.	6800.	12400.	9440.
				Efficiency %	62	71	74	78	75
350.	5.00	Mechanical	Input Power kW	0.74	1.27	2.73	4.28	5.96	
			Output Torque Nm	746.	1470.	3050.	5660.	8070.	
			Efficiency %	53	58	61	67	75	
		Thermal	Input Power kW	1.42	2.22	3.23	5.56	7.44	
			Output Torque Nm	1510.	2710.	3640.	7450.	10100.	
			Efficiency %	53	58	61	67	75	
375.	4.67	Mechanical	Input Power kW	1.38	1.73	4.33	5.14	5.24	
			Output Torque Nm	1720.	2360.	5980.	8020.	8020.	
			Efficiency %	59	65	69	75	74	
		Thermal	Input Power kW	1.58	3.78	5.94	8.95	9.39	
			Output Torque Nm	1990.	5370.	8270.	14100.	14700.	
			Efficiency %	59	65	69	75	74	
400.	4.38	Mechanical	Input Power kW	1.02	1.86	4.04	5.30	5.25	
			Output Torque Nm	1270.	2630.	6130.	8640.	7460.	
			Efficiency %	59	68	70	75	66	
		Thermal	Input Power kW	1.77	3.19	4.46	7.74	5.30	
			Output Torque Nm	2310.	4610.	6800.	12700.	7540.	
			Efficiency %	59	68	70	75	66	
450.	3.89	Mechanical	Input Power kW	1.09	2.10	3.92	4.85	4.83	
			Output Torque Nm	1570.	3200.	6130.	8640.	8400.	
			Efficiency %	59	64	66	70	74	
		Thermal	Input Power kW	1.72	2.46	3.58	6.04	6.92	
			Output Torque Nm	2550.	3780.	5570.	10800.	12200.	
			Efficiency %	59	64	66	70	74	
500.	3.50	Mechanical	Input Power kW	1.25	1.78	3.07	4.48	4.32	
			Output Torque Nm	1900.	3030.	5390.	8490.	8490.	
			Efficiency %	56	64	67	73	73	
		Thermal	Input Power kW	1.77	2.58	4.10	6.66	6.52	
			Output Torque Nm	2740.	4480.	7270.	12700.	12900.	
			Efficiency %	56	64	67	73	73	
600.	2.92	Mechanical	Input Power kW	0.97	1.18	2.92	3.44	2.44	
			Output Torque Nm	1710.	2350.	5950.	7980.	5830.	
			Efficiency %	52	59	64	69	77	
		Thermal	Input Power kW	1.26	3.69	5.25	6.52	3.99	
			Output Torque Nm	2270.	7830.	10900.	15400.	9570.	
			Efficiency %	52	59	64	69	77	
625.	2.80	Mechanical	Input Power kW	1.06	1.52	2.64	3.66	3.76	
			Output Torque Nm	1890.	3030.	5470.	8470.	8470.	
			Efficiency %	52	58	62	69	69	
		Thermal	Input Power kW	1.58	2.66	3.99	6.22	6.25	
			Output Torque Nm	2910.	5480.	8440.	14600.	14500.	
			Efficiency %	52	58	62	69	69	
700.	2.50	Mechanical	Input Power kW	0.69	1.03	1.60	2.31	3.48	
			Output Torque Nm	1180.	2040.	3390.	5460.	8200.	
			Efficiency %	46	53	57	63	64	
		Thermal	Input Power kW	0.63	1.72	2.76	3.73	4.63	
			Output Torque Nm	1060.	3570.	6030.	8980.	11100.	
			Efficiency %	46	53	57	63	64	
750.	2.33	Mechanical	Input Power kW	0.83	0.98	2.45	2.85	2.57	
			Output Torque Nm	1710.	2340.	5930.	7960.	7960.	
			Efficiency %	49	56	60	67	74	
		Thermal	Input Power kW	0.92	2.74	4.26	5.39	5.02	
			Output Torque Nm	1910.	6980.	10500.	15300.	15700.	
			Efficiency %	49	56	60	67	74	
800.	2.19	Mechanical	Input Power kW	0.61	1.08	2.32	2.93	3.03	
			Output Torque Nm	1260.	2610.	6130.	8640.	8640.	
			Efficiency %	48	57	59	66	65	
		Thermal	Input Power kW	1.26	3.12	4.16	6.52	4.65	
			Output Torque Nm	2800.	8020.	11300.	19600.	13500.	
			Efficiency %	48	57	59	66	65	

SERIES AM

RATINGS AT 1750 RPM INPUT

	NOMINAL RATIO	NOMINAL OUTPUT SPEED REV / MIN	CAPACITY		SIZE OF UNIT				
					A1002	A1252	A1602	A2002 Reducer	A2002 Motorised
DOUBLE REDUCTION	900.	1.94	Mechanical	Input Power kW	0.73	0.88	2.14	2.46	2.83
				Output Torque Nm	1710.	2340.	5920.	7940.	8540.
				Efficiency %	46	53	58	64	63
			Thermal	Input Power kW	0.80	2.22	3.56	4.55	4.12
				Output Torque Nm	1890.	6380.	10100.	15000.	12600.
				Efficiency %	46	53	57	64	62
	1000.	1.75	Mechanical	Input Power kW	0.76	1.05	1.85	2.47	2.54
				Output Torque Nm	1890.	3010.	5610.	8440.	8640.
				Efficiency %	46	53	57	64	62
			Thermal	Input Power kW	1.26	2.63	3.62	5.58	3.90
				Output Torque Nm	3300.	8070.	11400.	19500.	13500.
				Efficiency %	46	53	57	64	62
	1200.	1.46	Mechanical	Input Power kW	0.58	1.01	1.79	2.22	2.01
				Output Torque Nm	1620.	3320.	6130.	8640.	7760.
				Efficiency %	43	50	52	59	59
			Thermal	Input Power kW	1.26	2.36	3.30	5.07	3.28
				Output Torque Nm	3860.	8250.	11700.	20300.	13000.
				Efficiency %	43	50	52	59	59
	1250.	1.40	Mechanical	Input Power kW	0.65	0.88	1.58	2.05	1.84
				Output Torque Nm	1890.	3010.	5670.	8420.	8420.
				Efficiency %	42	50	54	61	69
			Thermal	Input Power kW	0.92	2.63	3.49	5.30	4.82
				Output Torque Nm	2780.	9730.	13100.	22400.	22400.
				Efficiency %	42	50	54	61	69
	1400.	1.25	Mechanical	Input Power kW	0.43	0.74	1.56	1.92	2.07
				Output Torque Nm	1260.	2600.	6130.	8640.	8620.
				Efficiency %	39	47	50	57	56
			Thermal	Input Power kW	0.63	1.72	2.76	3.73	3.67
				Output Torque Nm	1940.	6540.	11300.	17200.	16000.
				Efficiency %	39	47	50	57	56
	1500.	1.17	Mechanical	Input Power kW	0.57	0.79	1.40	1.79	1.66
				Output Torque Nm	1880.	3010.	5710.	8410.	8640.
				Efficiency %	40	47	51	59	64
			Thermal	Input Power kW	0.80	2.22	3.42	4.55	4.40
				Output Torque Nm	2730.	9260.	14800.	22200.	23300.
				Efficiency %	40	47	51	59	64
	1600.	1.09	Mechanical	Input Power kW	0.52	0.67	1.46	1.77	1.71
				Output Torque Nm	1760.	2640.	6130.	8640.	8610.
				Efficiency %	39	45	48	56	60
			Thermal	Input Power kW	1.26	1.92	2.61	4.02	3.36
				Output Torque Nm	4730.	8480.	11500.	20400.	17200.
				Efficiency %	39	45	48	56	60
1750.	1.00	Mechanical	Input Power kW	0.53	0.72	1.28	1.62	1.66	
			Output Torque Nm	1880.	3000.	5750.	8390.	7750.	
			Efficiency %	37	44	48	55	53	
		Thermal	Input Power kW	0.63	1.72	2.76	3.73	3.09	
			Output Torque Nm	2270.	7820.	13100.	20100.	15300.	
			Efficiency %	37	44	48	55	53	
1800.	0.97	Mechanical	Input Power kW	0.44	0.76	1.34	1.62	1.47	
			Output Torque Nm	1620.	3310.	6130.	8640.	8640.	
			Efficiency %	37	44	47	54	61	
		Thermal	Input Power kW	0.80	2.22	3.14	4.55	3.61	
			Output Torque Nm	3200.	10600.	15200.	25300.	21600.	
			Efficiency %	37	44	47	54	61	
2000.	0.88	Mechanical	Input Power kW	0.45	0.57	1.24	1.48	1.43	
			Output Torque Nm	1760.	2640.	6130.	8640.	8600.	
			Efficiency %	36	43	45	53	55	
		Thermal	Input Power kW	0.92	1.87	2.54	3.84	3.22	
			Output Torque Nm	3970.	9920.	13200.	23400.	20300.	
			Efficiency %	36	43	45	53	55	
2100.	0.83	Mechanical	Input Power kW	0.41	0.70	1.22	1.47	1.23	
			Output Torque Nm	1620.	3310.	6130.	8640.	8640.	
			Efficiency %	34	42	44	51	62	
		Thermal	Input Power kW	0.63	1.72	2.76	3.73	4.05	
			Output Torque Nm	2650.	8960.	14800.	22800.	28900.	
			Efficiency %	34	42	44	51	62	
2400.	0.73	Mechanical	Input Power kW	0.40	0.51	1.09	1.30	1.13	
			Output Torque Nm	1760.	2630.	6130.	8640.	8640.	
			Efficiency %	34	39	43	51	62	
		Thermal	Input Power kW	0.80	1.87	2.49	3.74	3.96	
			Output Torque Nm	3900.	11200.	14900.	26300.	30700.	
			Efficiency %	34	39	43	51	62	
2500.	0.70	Mechanical	Input Power kW	0.33	0.49	1.01	1.25	1.10	
			Output Torque Nm	1420.	2590.	5820.	8580.	8580.	
			Efficiency %	31	39	42	50	57	
		Thermal	Input Power kW	0.92	1.52	2.18	3.21	2.90	
			Output Torque Nm	4750.	9310.	13500.	23200.	23200.	
			Efficiency %	31	39	42	50	57	
2800.	0.63	Mechanical	Input Power kW	0.38	0.47	1.00	1.18	1.10	
			Output Torque Nm	1760.	2630.	6130.	8640.	8580.	
			Efficiency %	31	36	40	48	53	
		Thermal	Input Power kW	0.63	1.72	2.49	3.73	2.96	
			Output Torque Nm	3230.	11400.	16500.	29000.	24300.	
			Efficiency %	31	36	40	48	53	
3000.	0.58	Mechanical	Input Power kW	0.30	0.45	0.90	1.10	0.87	
			Output Torque Nm	1430.	2590.	5890.	8570.	7720.	
			Efficiency %	29	36	40	48	54	
		Thermal	Input Power kW	0.80	1.51	2.14	3.13	2.43	
			Output Torque Nm	4660.	10500.	15200.	26100.	22300.	
			Efficiency %	29	36	40	48	54	
3500.	0.50	Mechanical	Input Power kW	0.28	0.41	0.84	1.00	0.69	
			Output Torque Nm	1430.	2590.	5950.	8570.	6830.	
			Efficiency %	27	33	37	45	52	
		Thermal	Input Power kW	0.63	1.52	2.14	3.13	2.16	
			Output Torque Nm	3850.	11700.	16800.	28900.	22100.	
			Efficiency %	27	33	37	45	52	
3600.	0.49	Mechanical	Input Power kW	0.23	0.35	0.65	0.88	0.81	
			Output Torque Nm	1090.	2140.	4480.	7710.	8570.	
			Efficiency %	25	31	35	45	56	
		Thermal	Input Power kW	0.80	1.32	1.81	2.63	2.65	
			Output Torque Nm	5260.	10500.	14300.	25100.	28600.	
			Efficiency %	25	31	35	45	56	
4200.	0.42	Mechanical	Input Power kW	0.22	0.33	0.60	0.81	0.64	
			Output Torque Nm	1110.	2160.	4520.	7700.	7700.	
			Efficiency %	22	29	33	42	53	
		Thermal	Input Power kW	0.63	1.33	1.81	2.63	2.22	
			Output Torque Nm	4350.	11600.	15900.	27700.	27500.	
			Efficiency %	22	29	33	42	53	

	NOMINAL RATIO	NOMINAL OUTPUT SPEED REV / MIN	CAPACITY		SIZE OF UNIT			
					A1002	A1252	A1602	A2002
SINGLE REDUCTION	5.0	290.00	Mechanical	Input Power kW	17.90	30.90	57.70	98.90
				Output Torque Nm	579.	1000.	1880.	3200.
			Thermal	Input Power kW	23.80	38.20	60.80	104.00
				Output Torque Nm	772.	1240.	1980.	3370.
				Efficiency %	96	96	97	96
			7.5	193.33	Mechanical	Input Power kW	14.30	25.20
	Output Torque Nm	655.				1160.	2060.	3660.
	Thermal	Input Power kW			18.30	29.00	48.10	84.80
		Output Torque Nm			842.	1340.	2290.	4050.
		Efficiency %			94	94	96	96
	10.0	145.00			Mechanical	Input Power kW	11.70	20.80
			Output Torque Nm	700.		1260.	2310.	4080.
			Thermal	Input Power kW	16.20	25.30	41.90	74.10
				Output Torque Nm	975.	1530.	2560.	4550.
				Efficiency %	93	94	94	95
			12.5	116.00	Mechanical	Input Power kW	10.00	18.00
	Output Torque Nm	752.				1360.	2440.	4380.
	Thermal	Input Power kW			13.70	21.40	37.00	65.70
		Output Torque Nm			1030.	1620.	2800.	5010.
		Efficiency %			93	93	94	94
	15.0	96.67			Mechanical	Input Power kW	9.24	15.10
			Output Torque Nm	855.		1410.	2660.	4730.
			Thermal	Input Power kW	11.20	18.80	31.60	57.50
				Output Torque Nm	1040.	1770.	2830.	5440.
				Efficiency %	91	91	93	93
			20.0	72.50	Mechanical	Input Power kW	6.61	13.10
	Output Torque Nm	758.				1510.	2830.	5140.
	Thermal	Input Power kW			10.10	15.80	23.20	44.60
		Output Torque Nm			1170.	1840.	2830.	5540.
		Efficiency %			89	90	90	92
	25.0	58.00			Mechanical	Input Power kW	7.87	12.40
			Output Torque Nm	1120.		1790.	2640.	5000.
Thermal			Input Power kW	7.58	12.40	20.90	39.80	
			Output Torque Nm	1080.	1800.	3010.	5830.	
			Efficiency %	87	88	89	91	
30.0			48.33	Mechanical	Input Power kW	5.75	11.50	20.80
	Output Torque Nm	964.			1960.	3570.	6990.	
	Thermal	Input Power kW		6.90	10.80	16.30	30.80	
		Output Torque Nm		1160.	1830.	2770.	5380.	
		Efficiency %		85	86	86	88	
	40.0	36.25		Mechanical	Input Power kW	4.45	7.15	14.70
Output Torque Nm			950.		1560.	3250.	5820.	
Thermal			Input Power kW	5.53	9.22	13.60	26.30	
			Output Torque Nm	1190.	2030.	2990.	5970.	
			Efficiency %	81	83	83	86	
50.0			29.00	Mechanical	Input Power kW	3.31	5.82	11.40
	Output Torque Nm	851.			1540.	3060.	5090.	
	Thermal	Input Power kW		4.91	7.88	12.10	22.10	
		Output Torque Nm		1280.	2100.	3250.	6130.	
		Efficiency %		78	80	82	84	
	60.0	24.17		Mechanical	Input Power kW	2.74	4.34	9.07
Output Torque Nm			813.		1320.	2830.	4570.	
Thermal			Input Power kW	4.20	6.74	10.30	18.20	
			Output Torque Nm	1270.	2090.	3210.	5900.	
			Efficiency %	75	77	79	81	
70.0			20.71	Mechanical	Input Power kW	2.03	3.45	7.81
	Output Torque Nm	659.			1190.	2700.	4180.	
	Thermal	Input Power kW		3.46	5.85	8.29	15.70	
		Output Torque Nm		1150.	2060.	2870.	5810.	
		Efficiency %		70	75	75	79	

Only suitable for mounting positions 1, 3 and 4

For mounting positions 2, 5 and 6 refer to our Application Engineers

SERIES AM

RATINGS AT 1450 RPM INPUT

	NOMINAL RATIO	NOMINAL OUTPUT SPEED REV / MIN	CAPACITY		SIZE OF UNIT				
					A1002	A1252	A1602	A2002 Reducer	A2002 Motorised
DOUBLE REDUCTION	75.0	19.33	Mechanical	Input Power kW	3.57	4.57	11.80	15.00	12.90
				Output Torque Nm	1420.	1960.	4630.	6670.	5510.
				Efficiency %	77	81	84	86	84
			Thermal	Input Power kW	3.44	5.44	9.36	15.80	14.20
				Output Torque Nm	1360.	2340.	3650.	7060.	6090.
				Efficiency %	77	81	84	86	84
	100.	14.50	Mechanical	Input Power kW	2.15	4.14	9.27	12.60	12.90
				Output Torque Nm	1050.	2170.	4850.	7300.	6810.
				Efficiency %	76	78	80	83	83
			Thermal	Input Power kW	3.17	4.64	7.02	12.50	12.70
				Output Torque Nm	1550.	2450.	3650.	7200.	6710.
				Efficiency %	76	78	80	83	83
	125.	11.60	Mechanical	Input Power kW	2.63	3.89	7.29	10.40	10.30
				Output Torque Nm	1550.	2500.	4460.	7010.	6770.
				Efficiency %	72	75	78	81	83
			Thermal	Input Power kW	2.42	3.71	6.36	11.20	12.70
				Output Torque Nm	1430.	2380.	3880.	7570.	8350.
				Efficiency %	72	75	78	81	83
	150.	9.67	Mechanical	Input Power kW	2.24	2.76	7.48	9.24	7.67
				Output Torque Nm	1600.	2220.	5550.	7490.	6280.
				Efficiency %	72	76	79	82	82
			Thermal	Input Power kW	2.67	4.09	6.81	11.60	8.56
				Output Torque Nm	1920.	3330.	5050.	9400.	7020.
				Efficiency %	72	76	79	82	82
	200.	7.25	Mechanical	Input Power kW	1.36	2.51	5.85	7.87	7.82
				Output Torque Nm	1180.	2460.	5740.	8210.	7610.
				Efficiency %	70	74	75	79	76
			Thermal	Input Power kW	2.48	3.52	5.15	9.18	8.05
				Output Torque Nm	2210.	3480.	5050.	9600.	7850.
				Efficiency %	70	74	75	79	76
	225.	6.44	Mechanical	Input Power kW	1.67	2.18	5.57	6.53	7.57
				Output Torque Nm	1710.	2340.	5920.	8040.	8640.
				Efficiency %	67	73	76	79	80
			Thermal	Input Power kW	2.30	3.73	5.97	9.81	9.61
				Output Torque Nm	2390.	4070.	6350.	12100.	11000.
				Efficiency %	67	73	76	79	80
	250.	5.80	Mechanical	Input Power kW	1.63	2.97	4.16	6.97	6.71
				Output Torque Nm	1640.	3290.	4760.	8640.	8640.
				Efficiency %	63	69	71	77	80
			Thermal	Input Power kW	1.49	4.06	5.86	7.58	8.56
				Output Torque Nm	1500.	4550.	6770.	9400.	11000.
				Efficiency %	63	69	71	77	80
	300.	4.83	Mechanical	Input Power kW	1.38	1.70	4.34	5.29	5.53
				Output Torque Nm	1720.	2360.	5980.	8030.	8190.
				Efficiency %	61	70	73	77	75
			Thermal	Input Power kW	1.67	3.60	5.69	9.29	7.29
				Output Torque Nm	2100.	5120.	7890.	14200.	10900.
				Efficiency %	61	70	73	77	75
350.	4.14	Mechanical	Input Power kW	0.64	1.08	2.34	3.71	5.13	
			Output Torque Nm	755.	1490.	3090.	5850.	8300.	
			Efficiency %	52	58	59	67	74	
		Thermal	Input Power kW	1.28	1.99	2.85	4.91	7.15	
			Output Torque Nm	1610.	2890.	3800.	7830.	11700.	
			Efficiency %	52	58	59	67	74	
375.	3.87	Mechanical	Input Power kW	1.16	1.45	3.64	4.30	4.37	
			Output Torque Nm	1720.	2360.	5960.	8000.	8010.	
			Efficiency %	58	64	68	74	74	
		Thermal	Input Power kW	1.49	3.69	5.79	7.58	8.26	
			Output Torque Nm	2230.	6260.	9610.	14200.	15400.	
			Efficiency %	58	64	68	74	74	
400.	3.63	Mechanical	Input Power kW	0.85	1.56	3.39	4.45	4.54	
			Output Torque Nm	1270.	2620.	6130.	8640.	7730.	
			Efficiency %	58	67	69	74	65	
		Thermal	Input Power kW	1.67	3.11	4.34	7.33	5.04	
			Output Torque Nm	2600.	5370.	7880.	14300.	8640.	
			Efficiency %	58	67	69	74	65	
450.	3.22	Mechanical	Input Power kW	0.94	1.81	3.30	4.08	4.08	
			Output Torque Nm	1620.	3300.	6130.	8640.	8490.	
			Efficiency %	58	64	65	69	73	
		Thermal	Input Power kW	1.63	2.31	3.35	5.64	6.35	
			Output Torque Nm	2890.	4240.	6220.	12000.	13300.	
			Efficiency %	58	64	65	69	73	
500.	2.90	Mechanical	Input Power kW	1.06	1.49	2.61	3.75	3.62	
			Output Torque Nm	1890.	3030.	5450.	8480.	8480.	
			Efficiency %	54	63	66	72	72	
		Thermal	Input Power kW	1.67	2.52	3.85	6.18	6.05	
			Output Torque Nm	3070.	5220.	8150.	14100.	14300.	
			Efficiency %	54	63	66	72	72	
600.	2.42	Mechanical	Input Power kW	0.82	0.99	2.45	2.89	2.11	
			Output Torque Nm	1710.	2340.	5940.	7960.	6020.	
			Efficiency %	51	58	63	68	76	
		Thermal	Input Power kW	1.19	3.23	4.57	5.53	3.66	
			Output Torque Nm	2540.	8130.	11300.	15500.	10500.	
			Efficiency %	51	58	63	68	76	
625.	2.32	Mechanical	Input Power kW	0.89	1.28	2.25	3.07	3.14	
			Output Torque Nm	1890.	3020.	5530.	8460.	8460.	
			Efficiency %	51	57	61	68	68	
		Thermal	Input Power kW	1.49	2.60	3.76	5.89	5.89	
			Output Torque Nm	3260.	6390.	9460.	16500.	16300.	
			Efficiency %	51	57	61	68	68	
700.	2.07	Mechanical	Input Power kW	0.59	0.88	1.38	1.98	3.00	
			Output Torque Nm	1200.	2080.	3450.	5560.	8440.	
			Efficiency %	45	53	55	62	63	
		Thermal	Input Power kW	0.60	1.52	2.41	3.20	4.23	
			Output Torque Nm	1210.	3740.	6230.	9120.	12100.	
			Efficiency %	45	53	55	62	63	
750.	1.93	Mechanical	Input Power kW	0.70	0.83	2.06	2.39	2.14	
			Output Torque Nm	1710.	2340.	5920.	7940.	7940.	
			Efficiency %	48	55	60	66	74	
		Thermal	Input Power kW	0.87	2.41	3.72	4.61	4.44	
			Output Torque Nm	2160.	7270.	10900.	15600.	16600.	
			Efficiency %	48	55	60	66	74	
800.	1.81	Mechanical	Input Power kW	0.52	0.91	1.96	2.47	2.54	
			Output Torque Nm	1260.	2600.	6130.	8640.	8640.	
			Efficiency %	48	56	58	65	64	
		Thermal	Input Power kW	1.19	2.98	3.95	5.53	4.33	
			Output Torque Nm	3140.	9080.	12700.	19700.	14900.	
			Efficiency %	48	56	58	65	64	

SERIES AM

RATINGS AT 1450 RPM INPUT

	NOMINAL RATIO	NOMINAL OUTPUT SPEED REV / MIN	CAPACITY		SIZE OF UNIT				
					A1002	A1252	A1602	A2002 Reducer	A2002 Motorised
DOUBLE REDUCTION	900.	1.61	Mechanical	Input Power kW	0.62	0.74	1.80	2.07	2.40
				Output Torque Nm	1700.	2340.	5910.	7920.	8630
				Efficiency %	45	52	57	63	62
			Thermal	Input Power kW	0.76	1.96	3.10	3.89	3.80
				Output Torque Nm	2130.	6660.	10400.	15200.	13900
				Efficiency %	45	52	57	63	62
	1000.	1.45	Mechanical	Input Power kW	0.64	0.88	1.57	2.08	2.13
				Output Torque Nm	1890.	3010.	5660.	8420.	8620
				Efficiency %	45	52	56	63	61
			Thermal	Input Power kW	1.19	2.59	3.43	5.27	3.63
				Output Torque Nm	3680.	9450.	12800.	21900.	15000
				Efficiency %	45	52	56	63	61
	1200.	1.21	Mechanical	Input Power kW	0.49	0.85	1.51	1.87	1.68
				Output Torque Nm	1620.	3320.	6130.	8640.	7750
				Efficiency %	42	49	51	58	58
			Thermal	Input Power kW	1.19	2.27	3.14	4.81	3.04
				Output Torque Nm	4310.	9430.	13200.	22800.	14400
				Efficiency %	42	49	51	58	58
	1250.	1.16	Mechanical	Input Power kW	0.55	0.74	1.34	1.73	1.54
				Output Torque Nm	1880.	3010.	5710.	8400.	8410
				Efficiency %	41	49	53	60	68
			Thermal	Input Power kW	0.87	2.41	3.33	4.61	4.44
				Output Torque Nm	3130.	10600.	14800.	23100.	24600
				Efficiency %	41	49	53	60	68
	1400.	1.04	Mechanical	Input Power kW	0.37	0.62	1.32	1.62	1.73
				Output Torque Nm	1260.	2590.	6130.	8640.	8610
				Efficiency %	38	46	49	56	56
			Thermal	Input Power kW	0.60	1.52	2.41	3.20	3.43
				Output Torque Nm	2210.	6840.	11600.	17500.	17900
				Efficiency %	38	46	49	56	56
	1500.	0.97	Mechanical	Input Power kW	0.49	0.66	1.19	1.50	1.39
				Output Torque Nm	1880.	3000.	5760.	8390.	8640
				Efficiency %	39	46	50	58	63
			Thermal	Input Power kW	0.76	1.96	3.10	3.89	4.20
				Output Torque Nm	3080.	9650.	15800.	22500.	26500
				Efficiency %	39	46	50	58	63
	1600.	0.91	Mechanical	Input Power kW	0.44	0.56	1.23	1.49	1.44
				Output Torque Nm	1760.	2640.	6130.	8640.	8600
				Efficiency %	38	45	47	55	59
			Thermal	Input Power kW	1.19	1.85	2.48	3.82	3.16
				Output Torque Nm	5270.	9690.	12900.	22900.	19300
				Efficiency %	38	45	47	55	59
1750.	0.83	Mechanical	Input Power kW	0.45	0.61	1.10	1.37	1.38	
			Output Torque Nm	1880.	3000.	5820.	8380.	7740	
			Efficiency %	36	43	47	54	53	
		Thermal	Input Power kW	0.60	1.52	2.41	3.20	2.89	
			Output Torque Nm	2580.	8170.	13500.	20400.	17200	
			Efficiency %	36	43	47	54	53	
1800.	0.81	Mechanical	Input Power kW	0.37	0.64	1.13	1.37	1.23	
			Output Torque Nm	1620.	3310.	6130.	8640.	8640	
			Efficiency %	37	44	46	53	60	
		Thermal	Input Power kW	0.76	1.96	3.04	3.89	3.41	
			Output Torque Nm	3600.	11000.	17400.	25500.	24400	
			Efficiency %	37	44	46	53	60	
2000.	0.73	Mechanical	Input Power kW	0.38	0.48	1.05	1.25	1.20	
			Output Torque Nm	1760.	2630.	6130.	8640.	8590	
			Efficiency %	35	42	44	52	54	
		Thermal	Input Power kW	0.87	1.79	2.42	3.66	3.04	
			Output Torque Nm	4460.	11300.	15000.	26400.	22800	
			Efficiency %	35	42	44	52	54	
2100.	0.69	Mechanical	Input Power kW	0.35	0.59	1.03	1.25	1.03	
			Output Torque Nm	1620.	3310.	6130.	8640.	8640	
			Efficiency %	34	41	43	50	62	
		Thermal	Input Power kW	0.60	1.52	2.41	3.20	3.81	
			Output Torque Nm	3010.	9350.	15200.	23100.	32400	
			Efficiency %	34	41	43	50	62	
2400.	0.60	Mechanical	Input Power kW	0.34	0.43	0.93	1.10	0.95	
			Output Torque Nm	1760.	2630.	6130.	8640.	8640	
			Efficiency %	33	39	42	50	61	
		Thermal	Input Power kW	0.76	1.79	2.38	3.57	3.66	
			Output Torque Nm	4390.	12800.	16900.	29700.	33800	
			Efficiency %	33	39	42	50	61	
2500.	0.58	Mechanical	Input Power kW	0.28	0.41	0.86	1.05	0.92	
			Output Torque Nm	1430.	2590.	5900.	8570.	8570	
			Efficiency %	31	38	42	50	57	
		Thermal	Input Power kW	0.87	1.45	2.08	3.05	2.74	
			Output Torque Nm	5330.	10600.	15200.	26200.	26200	
			Efficiency %	31	38	42	50	57	
2800.	0.52	Mechanical	Input Power kW	0.32	0.40	0.85	1.00	0.92	
			Output Torque Nm	1760.	2630.	6130.	8640.	8570	
			Efficiency %	30	36	39	47	53	
		Thermal	Input Power kW	0.60	1.52	2.39	3.20	2.80	
			Output Torque Nm	3670.	11900.	18700.	29300.	27400	
			Efficiency %	30	36	39	47	53	
3000.	0.48	Mechanical	Input Power kW	0.25	0.37	0.77	0.93	0.73	
			Output Torque Nm	1430.	2590.	5960.	8560.	7710	
			Efficiency %	29	35	39	47	54	
		Thermal	Input Power kW	0.76	1.45	2.05	2.99	2.30	
			Output Torque Nm	5240.	12000.	17200.	29500.	25100	
			Efficiency %	29	35	39	47	54	
3500.	0.41	Mechanical	Input Power kW	0.24	0.35	0.72	0.85	0.59	
			Output Torque Nm	1430.	2580.	6020.	8560.	6910	
			Efficiency %	26	32	37	44	51	
		Thermal	Input Power kW	0.60	1.46	2.05	3.00	2.05	
			Output Torque Nm	4380.	13300.	19100.	32700.	25000	
			Efficiency %	26	32	37	44	51	
3600.	0.40	Mechanical	Input Power kW	0.19	0.29	0.55	0.74	0.68	
			Output Torque Nm	1110.	2160.	4530.	7700.	8560	
			Efficiency %	25	31	35	44	55	
		Thermal	Input Power kW	0.76	1.27	1.72	2.51	2.52	
			Output Torque Nm	5910.	11900.	16200.	28400.	32400	
			Efficiency %	25	31	35	44	55	
4200.	0.35	Mechanical	Input Power kW	0.18	0.28	0.51	0.68	0.54	
			Output Torque Nm	1120.	2180.	4570.	7700.	7700	
			Efficiency %	22	29	32	41	52	
		Thermal	Input Power kW	0.60	1.28	1.73	2.52	2.11	
			Output Torque Nm	4930.	13200.	18000.	31400.	31100	
			Efficiency %	22	29	32	41	52	

SERIES AM

RATINGS AT 1160 RPM INPUT

	NOMINAL RATIO	NOMINAL OUTPUT SPEED REV / MIN	CAPACITY		SIZE OF UNIT			
					A1002	A1252	A1602	A2002
SINGLE REDUCTION	5.0	232.00	Mechanical	Input Power kW	15.90	27.40	51.20	87.70
				Output Torque Nm	639.	1110.	2080.	3550.
			Thermal	Input Power kW	19.10	30.80	50.20	87.10
				Output Torque Nm	771.	1250.	2040.	3530.
			Efficiency %	95	96	96	97	
	7.5	154.67	Mechanical	Input Power kW	12.60	22.20	38.10	67.60
				Output Torque Nm	719.	1280.	2260.	4030.
			Thermal	Input Power kW	15.00	23.90	39.90	70.50
				Output Torque Nm	858.	1380.	2370.	4200.
			Efficiency %	94	95	95	96	
	10.0	116.00	Mechanical	Input Power kW	10.20	18.30	33.20	58.40
				Output Torque Nm	765.	1370.	2530.	4470.
			Thermal	Input Power kW	13.20	20.80	34.70	61.50
				Output Torque Nm	989.	1570.	2640.	4710.
			Efficiency %	93	93	94	95	
	12.5	92.80	Mechanical	Input Power kW	8.79	15.70	28.20	50.40
				Output Torque Nm	819.	1480.	2660.	4790.
			Thermal	Input Power kW	11.20	17.60	30.50	54.50
				Output Torque Nm	1040.	1660.	2880.	5180.
			Efficiency %	92	93	94	94	
	15.0	77.33	Mechanical	Input Power kW	8.09	12.80	25.90	43.20
				Output Torque Nm	930.	1490.	2900.	5090.
			Thermal	Input Power kW	9.12	15.40	26.10	47.60
				Output Torque Nm	1050.	1800.	2920.	5610.
			Efficiency %	90	91	93	93	
	20.0	58.00	Mechanical	Input Power kW	5.63	11.40	20.30	36.00
				Output Torque Nm	802.	1640.	3080.	5550.
			Thermal	Input Power kW	8.21	13.00	19.20	37.00
Output Torque Nm				1180.	1870.	2920.	5710.	
		Efficiency %	89	90	90	91		
25.0	46.40	Mechanical	Input Power kW	6.73	10.60	16.10	29.30	
			Output Torque Nm	1190.	1900.	2870.	5330.	
		Thermal	Input Power kW	6.21	10.20	17.30	32.90	
			Output Torque Nm	1090.	1830.	3090.	6010.	
		Efficiency %	85	87	88	90		
30.0	38.67	Mechanical	Input Power kW	4.92	9.90	18.20	34.20	
			Output Torque Nm	1020.	2090.	3880.	7440.	
		Thermal	Input Power kW	5.64	8.87	13.50	25.60	
			Output Torque Nm	1170.	1870.	2860.	5560.	
		Efficiency %	84	85	86	88		
40.0	29.00	Mechanical	Input Power kW	3.90	6.12	12.90	21.90	
			Output Torque Nm	1030.	1660.	3530.	6170.	
		Thermal	Input Power kW	4.52	7.57	11.30	21.80	
			Output Torque Nm	1200.	2060.	3080.	6150.	
		Efficiency %	80	82	83	86		
50.0	23.20	Mechanical	Input Power kW	2.83	4.99	9.97	15.70	
			Output Torque Nm	901.	1630.	3310.	5390.	
		Thermal	Input Power kW	4.08	6.48	10.00	18.60	
			Output Torque Nm	1310.	2130.	3330.	6390.	
		Efficiency %	77	79	81	83		
60.0	19.33	Mechanical	Input Power kW	2.32	3.72	7.91	12.10	
			Output Torque Nm	851.	1400.	3050.	4840.	
		Thermal	Input Power kW	3.55	5.60	8.63	15.30	
			Output Torque Nm	1320.	2140.	3330.	6150.	
		Efficiency %	74	76	78	81		
70.0	16.57	Mechanical	Input Power kW	1.69	2.96	6.48	9.78	
			Output Torque Nm	674.	1250.	2770.	4430.	
		Thermal	Input Power kW	2.94	4.82	7.00	13.20	
			Output Torque Nm	1200.	2090.	3000.	6050.	
		Efficiency %	69	73	74	79		

SERIES AM

RATINGS AT 1160 RPM INPUT

	NOMINAL RATIO	NOMINAL OUTPUT SPEED REV / MIN	CAPACITY		SIZE OF UNIT				
					A1002	A1252	A1602	A2002 Reducer	A2002 Motorised
DOUBLE REDUCTION	75.0	15.47	Mechanical	Input Power kW	3.03	3.86	10.20	12.60	10.30
				Output Torque Nm	1480	2050	4940	6970	5460
				Efficiency %	77	80	83	85	83
			Thermal	Input Power kW	3.11	4.88	8.32	14.00	13.40
				Output Torque Nm	1520	2600	4010	7730	7130
				Efficiency %	74	78	79	82	82
	100.	11.60	Mechanical	Input Power kW	1.83	3.50	7.98	10.70	10.30
				Output Torque Nm	1090	2270	5140	7630	6750
				Efficiency %	74	78	79	82	82
			Thermal	Input Power kW	2.87	4.18	6.25	11.10	12.00
				Output Torque Nm	1740	2720	4010	7890	7870
				Efficiency %	74	78	79	82	82
	125.	9.28	Mechanical	Input Power kW	2.24	3.31	6.26	8.78	9.02
				Output Torque Nm	1630	2620	4720	7330	7330
				Efficiency %	71	74	77	80	82
			Thermal	Input Power kW	2.19	3.35	5.68	9.94	10.90
				Output Torque Nm	1590	2650	4270	8310	8900
				Efficiency %	71	74	77	80	82
	150.	7.73	Mechanical	Input Power kW	1.88	2.31	6.29	7.74	6.67
				Output Torque Nm	1660	2300	5770	7750	6760
				Efficiency %	72	76	79	81	81
			Thermal	Input Power kW	2.47	3.78	6.23	10.50	7.40
				Output Torque Nm	2190	3790	5710	10600	7510
				Efficiency %	72	76	79	81	81
	200.	5.80	Mechanical	Input Power kW	1.14	2.11	4.98	6.61	6.56
				Output Torque Nm	1220	2550	6030	8510	7910
				Efficiency %	69	73	74	78	76
			Thermal	Input Power kW	2.30	3.25	4.72	8.37	7.62
				Output Torque Nm	2520	3980	5700	10800	9230
				Efficiency %	69	73	74	78	76
	225.	5.16	Mechanical	Input Power kW	1.36	1.78	4.57	5.29	6.13
				Output Torque Nm	1720	2360	5990	8030	8640
				Efficiency %	66	72	75	78	79
			Thermal	Input Power kW	2.12	3.57	5.67	9.12	7.87
				Output Torque Nm	2710	4820	7440	13900	11100
				Efficiency %	66	72	75	78	79
	250.	4.64	Mechanical	Input Power kW	1.33	2.45	3.44	5.67	5.43
				Output Torque Nm	1640	3340	4840	8640	8640
				Efficiency %	61	68	70	76	79
			Thermal	Input Power kW	1.38	3.47	4.94	6.21	7.40
				Output Torque Nm	1710	4770	7010	9460	11800
				Efficiency %	61	68	70	76	79
	300.	3.87	Mechanical	Input Power kW	1.13	1.38	3.52	4.28	4.63
				Output Torque Nm	1720	2360	5970	8010	8470
				Efficiency %	60	69	72	76	74
			Thermal	Input Power kW	1.55	3.50	5.51	8.21	6.75
				Output Torque Nm	2390	6140	9420	15500	12500
				Efficiency %	60	69	72	76	74
350.	3.31	Mechanical	Input Power kW	0.53	0.89	1.95	3.17	4.25	
			Output Torque Nm	766	1510	3130	6120	8490	
			Efficiency %	51	57	58	65	73	
		Thermal	Input Power kW	1.15	1.78	2.52	4.34	6.46	
			Output Torque Nm	1760	3170	4100	8480	13000	
			Efficiency %	51	57	58	65	73	
375.	3.09	Mechanical	Input Power kW	0.95	1.18	2.96	3.49	3.53	
			Output Torque Nm	1710	2350	5950	7980	7980	
			Efficiency %	56	62	67	72	73	
		Thermal	Input Power kW	1.38	3.47	4.94	6.21	6.82	
			Output Torque Nm	2540	7240	10100	14300	15700	
			Efficiency %	56	62	67	72	73	
400.	2.90	Mechanical	Input Power kW	0.69	1.26	2.76	3.62	3.81	
			Output Torque Nm	1270	2620	6130	8640	8030	
			Efficiency %	57	66	67	73	65	
		Thermal	Input Power kW	1.55	3.03	4.17	6.79	4.78	
			Output Torque Nm	2960	6440	9330	16300	10200	
			Efficiency %	57	66	67	73	65	
450.	2.58	Mechanical	Input Power kW	0.77	1.49	2.70	3.33	3.30	
			Output Torque Nm	1630	3340	6130	8640	8470	
			Efficiency %	57	63	63	68	72	
		Thermal	Input Power kW	1.59	2.22	3.19	5.35	5.88	
			Output Torque Nm	3470	5030	7280	14000	15300	
			Efficiency %	57	63	63	68	72	
500.	2.32	Mechanical	Input Power kW	0.86	1.21	2.15	3.05	2.93	
			Output Torque Nm	1890	3020	5520	8460	8460	
			Efficiency %	53	62	65	71	71	
		Thermal	Input Power kW	1.55	2.45	3.57	5.77	5.65	
			Output Torque Nm	3500	6260	9310	16200	16500	
			Efficiency %	53	62	65	71	71	
600.	1.93	Mechanical	Input Power kW	0.67	0.80	2.00	2.35	1.77	
			Output Torque Nm	1710	2340	5920	7940	6270	
			Efficiency %	50	57	61	67	75	
		Thermal	Input Power kW	1.10	2.76	3.89	4.52	3.33	
			Output Torque Nm	2890	8500	11700	15500	11800	
			Efficiency %	50	57	61	67	75	
625.	1.86	Mechanical	Input Power kW	0.73	1.04	1.85	2.49	2.53	
			Output Torque Nm	1890	3020	5590	8440	8440	
			Efficiency %	50	56	60	67	67	
		Thermal	Input Power kW	1.38	2.54	3.54	5.48	5.45	
			Output Torque Nm	3710	7680	11000	18800	18600	
			Efficiency %	50	56	60	67	67	
700.	1.66	Mechanical	Input Power kW	0.49	0.73	1.15	1.65	2.49	
			Output Torque Nm	1220	2120	3510	5660	8630	
			Efficiency %	44	52	54	61	62	
		Thermal	Input Power kW	0.56	1.31	2.05	2.72	3.86	
			Output Torque Nm	1400	3940	6470	9460	13600	
			Efficiency %	44	52	54	61	62	
750.	1.55	Mechanical	Input Power kW	0.58	0.67	1.69	1.95	1.73	
			Output Torque Nm	1700	2340	5910	7920	7920	
			Efficiency %	46	54	58	64	73	
		Thermal	Input Power kW	0.82	2.07	3.15	3.89	3.98	
			Output Torque Nm	2480	7620	11300	16100	18400	
			Efficiency %	46	54	58	64	73	
800.	1.45	Mechanical	Input Power kW	0.42	0.74	1.60	2.02	2.07	
			Output Torque Nm	1260	2600	6130	8640	8640	
			Efficiency %	47	55	57	63	63	
		Thermal	Input Power kW	1.10	2.76	3.76	4.52	4.05	
			Output Torque Nm	3570	10300	14800	19700	17200	
			Efficiency %	47	55	57	63	63	

SERIES AM

RATINGS AT 1160 RPM INPUT

	NOMINAL RATIO	NOMINAL OUTPUT SPEED REV / MIN	CAPACITY		SIZE OF UNIT				
					A1002	A1252	A1602	A2002 Reducer	A2002 Motorised
DOUBLE REDUCTION	900.	1.29	Mechanical	Input Power kW	0.51	0.60	1.48	1.69	1.95
				Output Torque Nm	1700.	2330.	5900.	7900.	8620.
				Efficiency %	44	51	55	62	61
			Thermal	Input Power kW	0.71	1.69	2.63	3.26	3.51
				Output Torque Nm	2450.	7000.	10700.	15500.	15800.
				Efficiency %	44	51	55	62	61
	1000.	1.16	Mechanical	Input Power kW	0.52	0.72	1.30	1.69	1.73
				Output Torque Nm	1880.	3010.	5710.	8400.	8610.
				Efficiency %	44	51	54	62	60
			Thermal	Input Power kW	1.10	2.56	3.24	4.52	3.36
				Output Torque Nm	4190.	11400.	14800.	23000.	17100.
				Efficiency %	44	51	54	62	60
	1200.	0.97	Mechanical	Input Power kW	0.40	0.69	1.24	1.54	1.37
				Output Torque Nm	1620.	3310.	6130.	8640.	7740.
				Efficiency %	41	48	50	57	57
			Thermal	Input Power kW	1.10	2.16	2.97	4.52	2.82
				Output Torque Nm	4890.	11000.	15300.	26200.	16400.
				Efficiency %	41	48	50	57	57
	1250.	0.93	Mechanical	Input Power kW	0.45	0.60	1.11	1.41	1.24
				Output Torque Nm	1880.	3000.	5780.	8390.	8390.
				Efficiency %	40	48	52	59	67
			Thermal	Input Power kW	0.82	2.07	3.15	3.89	3.98
				Output Torque Nm	3580.	11000.	17100.	23800.	27200.
				Efficiency %	40	48	52	59	67
	1400.	0.83	Mechanical	Input Power kW	0.30	0.51	1.09	1.33	1.40
				Output Torque Nm	1250.	2590.	6130.	8640.	8590.
				Efficiency %	37	45	48	55	55
			Thermal	Input Power kW	0.56	1.31	2.05	2.72	3.19
				Output Torque Nm	2560.	7210.	12000.	18100.	20500.
				Efficiency %	37	45	48	55	55
	1500.	0.77	Mechanical	Input Power kW	0.40	0.54	0.99	1.23	1.13
				Output Torque Nm	1880.	3000.	5850.	8380.	8640.
				Efficiency %	38	45	49	56	62
			Thermal	Input Power kW	0.71	1.69	2.63	3.26	3.95
				Output Torque Nm	3530.	10100.	16300.	23000.	30600.
				Efficiency %	38	45	49	56	62
	1600.	0.73	Mechanical	Input Power kW	0.36	0.46	1.01	1.22	1.17
				Output Torque Nm	1760.	2630.	6130.	8640.	8590.
				Efficiency %	37	44	46	54	58
			Thermal	Input Power kW	1.10	1.75	2.34	3.61	2.95
				Output Torque Nm	5970.	11300.	15000.	26400.	22200.
				Efficiency %	37	44	46	54	58
1750.	0.66	Mechanical	Input Power kW	0.37	0.50	0.91	1.12	1.12	
			Output Torque Nm	1880.	2990.	5910.	8370.	7730.	
			Efficiency %	35	42	46	53	52	
		Thermal	Input Power kW	0.56	1.31	2.05	2.72	2.68	
			Output Torque Nm	2980.	8590.	14000.	21100.	19700.	
			Efficiency %	35	42	46	53	52	
1800.	0.64	Mechanical	Input Power kW	0.31	0.52	0.93	1.12	1.00	
			Output Torque Nm	1610.	3310.	6130.	8640.	8640.	
			Efficiency %	36	43	45	52	59	
		Thermal	Input Power kW	0.71	1.69	2.63	3.26	3.20	
			Output Torque Nm	4130.	11600.	18300.	26100.	28100.	
			Efficiency %	36	43	45	52	59	
2000.	0.58	Mechanical	Input Power kW	0.31	0.39	0.86	1.02	0.98	
			Output Torque Nm	1760.	2630.	6130.	8640.	8570.	
			Efficiency %	34	41	43	51	53	
		Thermal	Input Power kW	0.82	1.71	2.30	3.46	2.85	
			Output Torque Nm	5100.	13100.	17300.	30500.	26300.	
			Efficiency %	34	41	43	51	53	
2100.	0.55	Mechanical	Input Power kW	0.29	0.48	0.85	1.02	0.84	
			Output Torque Nm	1610.	3300.	6130.	8640.	8640.	
			Efficiency %	33	40	42	49	61	
		Thermal	Input Power kW	0.56	1.31	2.05	2.72	3.45	
			Output Torque Nm	3480.	9830.	15600.	23900.	36100.	
			Efficiency %	33	40	42	49	61	
2400.	0.48	Mechanical	Input Power kW	0.28	0.35	0.76	0.90	0.77	
			Output Torque Nm	1760.	2630.	6130.	8640.	8640.	
			Efficiency %	32	38	41	49	60	
		Thermal	Input Power kW	0.71	1.69	2.27	3.26	3.33	
			Output Torque Nm	5030.	14700.	19600.	33100.	37900.	
			Efficiency %	32	38	41	49	60	
2500.	0.46	Mechanical	Input Power kW	0.23	0.33	0.72	0.86	0.75	
			Output Torque Nm	1430.	2580.	5970.	8560.	8560.	
			Efficiency %	30	38	41	48	56	
		Thermal	Input Power kW	0.82	1.38	1.97	2.89	2.58	
			Output Torque Nm	6090.	12300.	17700.	30300.	30300.	
			Efficiency %	30	38	41	48	56	
2800.	0.41	Mechanical	Input Power kW	0.26	0.32	0.70	0.82	0.75	
			Output Torque Nm	1750.	2620.	6130.	8640.	8560.	
			Efficiency %	29	35	38	46	52	
		Thermal	Input Power kW	0.56	1.31	2.05	2.72	2.64	
			Output Torque Nm	4240.	12500.	19500.	30300.	31800.	
			Efficiency %	29	35	38	46	52	
3000.	0.39	Mechanical	Input Power kW	0.20	0.30	0.64	0.76	0.59	
			Output Torque Nm	1430.	2580.	6040.	8550.	7700.	
			Efficiency %	28	34	38	46	53	
		Thermal	Input Power kW	0.71	1.38	1.95	2.84	2.17	
			Output Torque Nm	6000.	14000.	20000.	34200.	29100.	
			Efficiency %	28	34	38	46	53	
3500.	0.33	Mechanical	Input Power kW	0.19	0.28	0.59	0.69	0.49	
			Output Torque Nm	1430.	2580.	6100.	8540.	7010.	
			Efficiency %	26	32	36	43	50	
		Thermal	Input Power kW	0.56	1.31	1.96	2.72	1.92	
			Output Torque Nm	5050.	14600.	22200.	36100.	28900.	
			Efficiency %	26	32	36	43	50	
3600.	0.32	Mechanical	Input Power kW	0.16	0.24	0.45	0.61	0.55	
			Output Torque Nm	1120.	2190.	4590.	7690.	8550.	
			Efficiency %	24	31	34	43	54	
		Thermal	Input Power kW	0.71	1.21	1.64	2.38	2.38	
			Output Torque Nm	6760.	13900.	18800.	32800.	37600.	
			Efficiency %	24	31	34	43	54	
4200.	0.28	Mechanical	Input Power kW	0.15	0.23	0.42	0.56	0.44	
			Output Torque Nm	1130.	2210.	4640.	7690.	7690.	
			Efficiency %	22	28	32	40	52	
		Thermal	Input Power kW	0.56	1.22	1.65	2.40	2.00	
			Output Torque Nm	5690.	15500.	20900.	36500.	36100.	
			Efficiency %	22	28	32	40	52	

	NOMINAL RATIO	NOMINAL OUTPUT SPEED REV / MIN	CAPACITY		SIZE OF UNIT			
					A1002	A1252	A1602	A2002
SINGLE REDUCTION	5.0	192.00	Mechanical	Input Power kW	14.30	24.70	46.10	79.00
				Output Torque Nm	693.	1200.	2250.	3860.
			Thermal	Input Power kW	15.70	25.60	41.90	73.80
				Output Torque Nm	763.	1250.	2050.	3600.
				Efficiency %	95	95	96	96
			7.5	128.00	Mechanical	Input Power kW	11.20	19.90
	Output Torque Nm	775.				1380.	2440.	4350.
	Thermal	Input Power kW			12.60	20.20	33.80	59.90
		Output Torque Nm			867.	1400.	2420.	4300.
		Efficiency %			94	94	95	95
	10.0	96.00			Mechanical	Input Power kW	9.15	16.30
			Output Torque Nm	822.		1480.	2720.	4820.
			Thermal	Input Power kW	11.10	17.50	29.40	52.30
				Output Torque Nm	995.	1590.	2700.	4830.
				Efficiency %	93	94	94	95
			12.5	76.80	Mechanical	Input Power kW	7.83	14.10
	Output Torque Nm	879.				1590.	2860.	5150.
	Thermal	Input Power kW			9.53	14.80	25.80	46.20
		Output Torque Nm			1070.	1680.	2930.	5290.
		Efficiency %			92	92	93	94
	15.0	64.00			Mechanical	Input Power kW	7.21	11.10
			Output Torque Nm	997.		1560.	3110.	5320.
			Thermal	Input Power kW	7.79	13.00	22.10	40.30
				Output Torque Nm	1080.	1820.	2970.	5720.
				Efficiency %	90	91	92	93
			20.0	48.00	Mechanical	Input Power kW	4.90	9.99
	Output Torque Nm	838.				1730.	3310.	5810.
	Thermal	Input Power kW			7.00	10.90	16.30	31.40
		Output Torque Nm			1200.	1890.	2970.	5830.
		Efficiency %			88	89	89	91
	25.0	38.40			Mechanical	Input Power kW	5.87	9.22
			Output Torque Nm	1240.		1980.	3080.	5580.
Thermal			Input Power kW	5.31	8.62	14.60	27.90	
			Output Torque Nm	1120.	1850.	3140.	6120.	
			Efficiency %	85	86	88	90	
30.0			32.00	Mechanical	Input Power kW	4.29	8.65	16.30
	Output Torque Nm	1070.			2180.	4150.	7780.	
	Thermal	Input Power kW		4.82	7.49	11.50	21.80	
		Output Torque Nm		1200.	1880.	2920.	5680.	
		Efficiency %		84	84	85	87	
	40.0	24.00		Mechanical	Input Power kW	3.47	5.34	11.50
Output Torque Nm			1100.		1730.	3770.	6450.	
Thermal			Input Power kW	3.88	6.48	9.58	18.50	
			Output Torque Nm	1230.	2110.	3130.	6260.	
			Efficiency %	80	81	82	85	
50.0			19.20	Mechanical	Input Power kW	2.48	4.36	8.88
	Output Torque Nm	942.			1700.	3530.	5640.	
	Thermal	Input Power kW		3.45	5.55	8.51	16.00	
		Output Torque Nm		1320.	2180.	3380.	6570.	
		Efficiency %		76	78	80	83	
	60.0	16.00		Mechanical	Input Power kW	1.99	3.25	7.04
Output Torque Nm			868.		1470.	3240.	5070.	
Thermal			Input Power kW	3.04	4.86	7.40	13.00	
			Output Torque Nm	1340.	2220.	3410.	6260.	
			Efficiency %	73	76	77	80	
70.0			13.71	Mechanical	Input Power kW	1.45	2.58	5.54
	Output Torque Nm	687.			1310.	2820.	4640.	
	Thermal	Input Power kW		2.51	4.19	6.04	11.30	
		Output Torque Nm		1220.	2170.	3080.	6190.	
		Efficiency %		68	73	73	78	

SERIES AM

RATINGS AT 960 RPM INPUT

	NOMINAL RATIO	NOMINAL OUTPUT SPEED REV / MIN	CAPACITY		SIZE OF UNIT				
					A1002	A1252	A1602	A2002 Reducer	A2002 Motorised
DOUBLE REDUCTION	75.0	12.80	Mechanical	Input Power kW	2.63	3.34	8.98	10.90	8.53
				Output Torque Nm	1530.	2120.	5190.	7210.	5420.
				Efficiency %	75	79	82	84	82
			Thermal	Input Power kW	2.87	4.49	7.59	12.70	12.80
				Output Torque Nm	1670.	2860.	4380.	8420.	8170.
				Efficiency %	74	77	78	81	81
	100.	9.60	Mechanical	Input Power kW	1.58	3.03	7.00	9.28	8.53
				Output Torque Nm	1130.	2350.	5390.	7900.	6690.
				Efficiency %	74	77	78	81	81
			Thermal	Input Power kW	2.66	3.85	5.71	10.10	11.50
				Output Torque Nm	1920.	3000.	4380.	8590.	9030.
				Efficiency %	74	77	78	81	81
	125.	7.68	Mechanical	Input Power kW	1.95	2.87	5.49	7.62	8.03
				Output Torque Nm	1680.	2710.	4930.	7590.	7810.
				Efficiency %	74	77	78	81	81
			Thermal	Input Power kW	2.03	3.08	5.19	9.07	9.17
				Output Torque Nm	1750.	2920.	4660.	9060.	8930.
				Efficiency %	69	73	76	79	81
	150.	6.40	Mechanical	Input Power kW	1.62	1.99	5.41	6.66	5.92
				Output Torque Nm	1700.	2370.	5930.	7970.	7180.
				Efficiency %	70	75	78	80	80
			Thermal	Input Power kW	2.33	3.56	5.82	9.81	6.34
				Output Torque Nm	2470.	4280.	6370.	11800.	7700.
				Efficiency %	70	75	78	80	80
	200.	4.80	Mechanical	Input Power kW	0.98	1.82	4.25	5.62	5.65
				Output Torque Nm	1260.	2630.	6130.	8640.	8150.
				Efficiency %	68	72	73	77	75
			Thermal	Input Power kW	2.18	3.07	4.41	7.80	7.31
				Output Torque Nm	2850.	4490.	6370.	12000.	10600.
				Efficiency %	68	72	73	77	75
	225.	4.27	Mechanical	Input Power kW	1.14	1.49	3.82	4.42	5.13
				Output Torque Nm	1720.	2360.	5970.	8010.	8640.
				Efficiency %	65	71	74	77	78
			Thermal	Input Power kW	1.98	3.48	5.51	7.79	7.03
				Output Torque Nm	3020.	5620.	8650.	14200.	11900.
				Efficiency %	65	71	74	77	78
	250.	3.84	Mechanical	Input Power kW	1.12	2.07	2.92	4.75	4.54
				Output Torque Nm	1630.	3360.	4900.	8640.	8640.
				Efficiency %	60	67	69	75	78
			Thermal	Input Power kW	1.30	3.03	4.28	5.31	6.34
				Output Torque Nm	1910.	4960.	7230.	9650.	12100.
				Efficiency %	60	67	69	75	78
	300.	3.20	Mechanical	Input Power kW	0.95	1.15	2.95	3.58	3.88
				Output Torque Nm	1710.	2350.	5950.	7990.	8480.
				Efficiency %	58	68	71	75	73
			Thermal	Input Power kW	1.45	3.42	5.28	7.00	6.22
				Output Torque Nm	2670.	7170.	10800.	15800.	13700.
				Efficiency %	58	68	71	75	73
350.	2.74	Mechanical	Input Power kW	0.45	0.75	1.66	2.71	3.55	
			Output Torque Nm	774.	1530.	3170.	6220.	8470.	
			Efficiency %	50	56	57	64	72	
		Thermal	Input Power kW	1.05	1.64	2.28	3.93	6.00	
			Output Torque Nm	1920.	3480.	4410.	9110.	14500.	
			Efficiency %	50	56	57	64	72	
375.	2.56	Mechanical	Input Power kW	0.80	0.99	2.48	2.92	2.95	
			Output Torque Nm	1710.	2350.	5940.	7960.	7970.	
			Efficiency %	56	62	66	71	72	
		Thermal	Input Power kW	1.30	3.03	4.28	5.31	5.76	
			Output Torque Nm	2840.	7530.	10400.	14600.	15800.	
			Efficiency %	56	62	66	71	72	
400.	2.40	Mechanical	Input Power kW	0.58	1.06	2.32	3.03	3.29	
			Output Torque Nm	1270.	2610.	6130.	8640.	8280.	
			Efficiency %	56	65	66	72	64	
		Thermal	Input Power kW	1.45	2.92	3.93	6.38	4.47	
			Output Torque Nm	3300.	7430.	10500.	18300.	11400.	
			Efficiency %	56	65	66	72	64	
450.	2.13	Mechanical	Input Power kW	0.65	1.25	2.27	2.80	2.76	
			Output Torque Nm	1630.	3330.	6130.	8640.	8450.	
			Efficiency %	56	62	62	67	71	
		Thermal	Input Power kW	1.56	2.17	3.11	5.21	5.53	
			Output Torque Nm	4060.	5860.	8460.	16200.	17100.	
			Efficiency %	56	62	62	67	71	
500.	1.92	Mechanical	Input Power kW	0.73	1.02	1.82	2.55	2.45	
			Output Torque Nm	1890.	3020.	5580.	8440.	8440.	
			Efficiency %	52	61	65	70	70	
		Thermal	Input Power kW	1.45	2.40	3.40	5.43	5.30	
			Output Torque Nm	3890.	7310.	10600.	18200.	18500.	
			Efficiency %	52	61	65	70	70	
600.	1.60	Mechanical	Input Power kW	0.57	0.68	1.68	1.97	1.52	
			Output Torque Nm	1700.	2340.	5910.	7920.	6470.	
			Efficiency %	49	56	60	66	75	
		Thermal	Input Power kW	1.04	2.42	3.39	5.88	3.09	
			Output Torque Nm	3220.	8840.	12200.	15800.	13200.	
			Efficiency %	49	56	60	66	75	
625.	1.54	Mechanical	Input Power kW	0.62	0.88	1.57	2.09	2.12	
			Output Torque Nm	1890.	3010.	5640.	8430.	8430.	
			Efficiency %	49	55	59	66	66	
		Thermal	Input Power kW	1.30	2.50	3.36	5.18	5.14	
			Output Torque Nm	4130.	9000.	12400.	21200.	21000.	
			Efficiency %	49	55	59	66	66	
700.	1.37	Mechanical	Input Power kW	0.42	0.63	0.98	1.42	2.09	
			Output Torque Nm	1240.	2150.	3570.	5750.	8620.	
			Efficiency %	43	51	53	59	61	
		Thermal	Input Power kW	0.53	1.16	1.79	2.33	3.60	
			Output Torque Nm	1590.	4130.	6680.	9540.	15100.	
			Efficiency %	43	51	53	59	61	
750.	1.28	Mechanical	Input Power kW	0.49	0.57	1.42	1.64	1.44	
			Output Torque Nm	1700.	2330.	5900.	7900.	7900.	
			Efficiency %	45	53	57	63	72	
		Thermal	Input Power kW	0.77	1.82	2.74	3.32	3.65	
			Output Torque Nm	2780.	7940.	11600.	16200.	20100.	
			Efficiency %	45	53	57	63	72	
800.	1.20	Mechanical	Input Power kW	0.35	0.62	1.35	1.70	1.73	
			Output Torque Nm	1260.	2600.	6130.	8640.	8640.	
			Efficiency %	46	54	56	62	63	
		Thermal	Input Power kW	1.04	2.42	3.39	5.88	3.81	
			Output Torque Nm	3990.	10700.	15800.	20100.	19300.	
			Efficiency %	46	54	56	62	63	

SERIES AM

RATINGS AT 960 RPM INPUT

	NOMINAL RATIO	NOMINAL OUTPUT SPEED REV / MIN	CAPACITY		SIZE OF UNIT				
					A1002	A1252	A1602	A2002 Reducer	A2002 Motorised
DOUBLE REDUCTION	900.	1.07	Mechanical	Input Power kW	0.43	0.50	1.25	1.43	1.64
				Output Torque Nm	1700.	2330.	5890.	7890.	8610
				Efficiency %	43	50	54	60	60
			Thermal	Input Power kW	0.67	1.49	2.29	2.79	3.30
				Output Torque Nm	2750.	7300.	11100.	15700.	17700
				Efficiency %	43	50	54	60	60
	1000.	0.96	Mechanical	Input Power kW	0.44	0.60	1.10	1.42	1.45
				Output Torque Nm	1880.	3000.	5760.	8390.	8600
				Efficiency %	43	50	54	61	59
			Thermal	Input Power kW	1.04	2.42	3.09	3.88	3.17
				Output Torque Nm	4660.	12800.	16800.	23400.	19100
				Efficiency %	43	50	54	61	59
	1200.	0.80	Mechanical	Input Power kW	0.34	0.58	1.05	1.30	1.15
				Output Torque Nm	1620.	3310.	6130.	8640.	7730
				Efficiency %	40	48	49	56	56
			Thermal	Input Power kW	1.04	2.07	2.87	3.88	2.65
				Output Torque Nm	5440.	12500.	17500.	26600.	18400
				Efficiency %	40	48	49	56	56
	1250.	0.77	Mechanical	Input Power kW	0.38	0.51	0.95	1.19	1.04
				Output Torque Nm	1880.	3000.	5850.	8380.	8380
				Efficiency %	40	47	50	58	66
			Thermal	Input Power kW	0.77	1.82	2.74	3.32	3.65
				Output Torque Nm	4010.	11500.	17600.	24000.	29800
				Efficiency %	40	47	50	58	66
	1400.	0.69	Mechanical	Input Power kW	0.25	0.43	0.92	1.13	1.17
				Output Torque Nm	1250.	2580.	6130.	8640.	8580
				Efficiency %	37	44	47	54	55
			Thermal	Input Power kW	0.53	1.16	1.79	2.33	3.01
				Output Torque Nm	2890.	7530.	12400.	18200.	23000
				Efficiency %	37	44	47	54	55
	1500.	0.64	Mechanical	Input Power kW	0.34	0.46	0.85	1.04	0.95
				Output Torque Nm	1880.	2990.	5930.	8360.	8640
				Efficiency %	37	44	48	55	61
			Thermal	Input Power kW	0.67	1.49	2.29	2.79	3.65
				Output Torque Nm	3960.	10500.	16700.	23200.	33800
				Efficiency %	37	44	48	55	61
	1600.	0.60	Mechanical	Input Power kW	0.30	0.38	0.85	1.03	0.98
				Output Torque Nm	1760.	2630.	6130.	8640.	8580
				Efficiency %	36	43	45	53	57
			Thermal	Input Power kW	1.04	1.69	2.24	3.44	2.79
				Output Torque Nm	6640.	12800.	16900.	29900.	25100
				Efficiency %	36	43	45	53	57
1750.	0.55	Mechanical	Input Power kW	0.31	0.42	0.78	0.95	0.94	
			Output Torque Nm	1870.	2990.	5990.	8350.	7720	
			Efficiency %	34	41	45	52	51	
		Thermal	Input Power kW	0.53	1.16	1.79	2.33	2.53	
			Output Torque Nm	3360.	8970.	14400.	21200.	22100	
			Efficiency %	34	41	45	52	51	
1800.	0.53	Mechanical	Input Power kW	0.26	0.44	0.79	0.95	0.84	
			Output Torque Nm	1610.	3300.	6130.	8640.	8640	
			Efficiency %	35	42	44	51	59	
		Thermal	Input Power kW	0.67	1.49	2.29	2.79	3.04	
			Output Torque Nm	4630.	12000.	18700.	26200.	31900	
			Efficiency %	35	42	44	51	59	
2000.	0.48	Mechanical	Input Power kW	0.26	0.32	0.73	0.87	0.82	
			Output Torque Nm	1760.	2630.	6130.	8640.	8560	
			Efficiency %	34	41	42	50	53	
		Thermal	Input Power kW	0.77	1.64	2.21	3.32	2.71	
			Output Torque Nm	5700.	15000.	19700.	34500.	29700	
			Efficiency %	34	41	42	50	53	
2100	0.46	Mechanical	Input Power kW	0.24	0.41	0.72	0.87	0.70	
			Output Torque Nm	1610.	3300.	6130.	8640.	8640	
			Efficiency %	32	39	41	48	60	
		Thermal	Input Power kW	0.53	1.16	1.79	2.33	3.20	
			Output Torque Nm	3930.	10200.	16100.	24000.	40000	
			Efficiency %	32	39	41	48	60	
2400.	0.40	Mechanical	Input Power kW	0.23	0.29	0.64	0.76	0.65	
			Output Torque Nm	1750.	2620.	6130.	8640.	8640	
			Efficiency %	31	37	40	48	59	
		Thermal	Input Power kW	0.67	1.49	2.19	2.79	3.09	
			Output Torque Nm	5630.	15300.	22300.	33200.	42000	
			Efficiency %	31	37	40	48	59	
2500.	0.38	Mechanical	Input Power kW	0.19	0.28	0.61	0.73	0.63	
			Output Torque Nm	1430.	2580.	6050.	8550.	8550	
			Efficiency %	28	34	37	45	52	
		Thermal	Input Power kW	0.77	1.32	1.89	2.77	2.46	
			Output Torque Nm	6800.	14000.	20100.	34400.	34300	
			Efficiency %	30	37	40	47	55	
2800.	0.34	Mechanical	Input Power kW	0.22	0.27	0.59	0.70	0.63	
			Output Torque Nm	1750.	2620.	6130.	8640.	8550	
			Efficiency %	29	35	37	45	51	
		Thermal	Input Power kW	0.53	1.16	1.79	2.33	2.52	
			Output Torque Nm	4770.	13000.	20000.	30400.	36000	
			Efficiency %	29	35	37	45	51	
3000.	0.32	Mechanical	Input Power kW	0.17	0.25	0.55	0.64	0.50	
			Output Torque Nm	1430.	2580.	6110.	8540.	7690	
			Efficiency %	28	34	37	45	52	
		Thermal	Input Power kW	0.67	1.34	1.88	2.74	2.06	
			Output Torque Nm	6710.	16000.	22800.	38900.	33000	
			Efficiency %	28	34	37	45	52	
3500.	0.27	Mechanical	Input Power kW	0.16	0.24	0.50	0.59	0.41	
			Output Torque Nm	1430.	2580.	6130.	8540.	7050	
			Efficiency %	25	31	35	42	50	
		Thermal	Input Power kW	0.53	1.16	1.79	2.33	1.83	
			Output Torque Nm	5690.	15200.	23900.	36200.	32700	
			Efficiency %	25	31	35	42	50	
3600.	0.27	Mechanical	Input Power kW	0.13	0.20	0.39	0.51	0.46	
			Output Torque Nm	1130.	2220.	4640.	7680.	8540	
			Efficiency %	24	31	33	42	54	
		Thermal	Input Power kW	0.67	1.17	1.58	2.30	2.27	
			Output Torque Nm	7560.	15900.	21400.	37300.	42800	
			Efficiency %	24	31	33	42	54	
4200.	0.23	Mechanical	Input Power kW	0.13	0.19	0.36	0.47	0.37	
			Output Torque Nm	1140.	2220.	4690.	7680.	7680	
			Efficiency %	22	28	31	39	51	
		Thermal	Input Power kW	0.53	1.16	1.59	2.33	1.91	
			Output Torque Nm	6400.	17400.	23800.	41500.	41100	
			Efficiency %	22	28	31	39	51	

	NOMINAL RATIO	NOMINAL OUTPUT SPEED REV / MIN	CAPACITY		SIZE OF UNIT			
					A1002	A1252	A1602	A2002
SINGLE REDUCTION	5.0	145.00	Mechanical	Input Power kW	12.10	21.00	39.30	67.40
				Output Torque Nm	776.	1350.	2530.	4340.
			Thermal	Input Power kW	12.00	19.30	31.70	55.90
				Output Torque Nm	764.	1240.	2040.	3600.
		Efficiency %	94	95	95	96		
	7.5	96.67	Mechanical	Input Power kW	9.50	16.80	28.80	51.20
				Output Torque Nm	862.	1530.	2720.	4850.
			Thermal	Input Power kW	9.86	15.70	26.30	46.70
				Output Torque Nm	894.	1430.	2480.	4420.
		Efficiency %	93	93	95	95		
	10.0	72.50	Mechanical	Input Power kW	7.71	13.80	25.00	44.10
				Output Torque Nm	912.	1640.	3030.	5360.
			Thermal	Input Power kW	8.68	13.80	22.80	40.70
				Output Torque Nm	1030.	1640.	2750.	4950.
		Efficiency %	92	93	93	94		
	12.5	58.00	Mechanical	Input Power kW	6.60	11.80	21.20	37.90
				Output Torque Nm	973.	1760.	3180.	5720.
			Thermal	Input Power kW	7.37	11.70	19.90	35.90
				Output Torque Nm	1090.	1730.	2980.	5410.
		Efficiency %	91	91	93	93		
	15.0	48.33	Mechanical	Input Power kW	6.09	9.01	19.50	30.30
				Output Torque Nm	1100.	1660.	3450.	5650.
			Thermal	Input Power kW	6.03	10.20	17.10	31.20
				Output Torque Nm	1090.	1880.	3020.	5830.
		Efficiency %	89	90	91	92		
	20.0	36.25	Mechanical	Input Power kW	3.97	8.09	15.30	25.30
				Output Torque Nm	890.	1840.	3660.	6170.
			Thermal	Input Power kW	5.46	8.59	12.70	24.40
Output Torque Nm				1230.	1950.	3030.	5940.	
	Efficiency %	87	89	88	90			
25.0	29.00	Mechanical	Input Power kW	4.79	7.49	12.10	20.60	
			Output Torque Nm	1320.	2110.	3400.	5930.	
		Thermal	Input Power kW	4.14	6.80	11.40	21.60	
			Output Torque Nm	1140.	1910.	3200.	6220.	
	Efficiency %	84	85	87	89			
30.0	24.17	Mechanical	Input Power kW	3.50	7.04	13.80	24.20	
			Output Torque Nm	1130.	2320.	4580.	8270.	
		Thermal	Input Power kW	3.78	5.92	9.01	17.00	
			Output Torque Nm	1220.	1950.	2990.	5810.	
	Efficiency %	82	83	84	86			
40.0	18.13	Mechanical	Input Power kW	2.92	4.36	9.69	15.50	
			Output Torque Nm	1200.	1840.	4130.	6860.	
		Thermal	Input Power kW	3.05	5.07	7.50	14.40	
			Output Torque Nm	1250.	2150.	3190.	6370.	
	Efficiency %	78	80	81	84			
50.0	14.50	Mechanical	Input Power kW	2.04	3.57	7.45	11.20	
			Output Torque Nm	1000.	1810.	3860.	5990.	
		Thermal	Input Power kW	2.73	4.36	6.76	12.60	
			Output Torque Nm	1350.	2220.	3490.	6740.	
	Efficiency %	74	77	78	81			
60.0	12.08	Mechanical	Input Power kW	1.58	2.66	5.90	8.62	
			Output Torque Nm	892.	1560.	3530.	5390.	
		Thermal	Input Power kW	2.44	3.87	5.98	10.50	
			Output Torque Nm	1390.	2290.	3580.	6580.	
	Efficiency %	71	74	76	79			
70.0	10.36	Mechanical	Input Power kW	1.15	2.11	4.39	6.97	
			Output Torque Nm	705.	1390.	2890.	4930.	
		Thermal	Input Power kW	2.02	3.35	4.90	9.14	
			Output Torque Nm	1260.	2240.	3240.	6510.	
	Efficiency %	66	71	71	77			

SERIES AM

RATINGS AT 725 RPM INPUT

	NOMINAL RATIO	NOMINAL OUTPUT SPEED REV / MIN	CAPACITY		SIZE OF UNIT				
					A1002	A1252	A1602	A2002 Reducer	A2002 Motorised
DOUBLE REDUCTION	75.0	9.67	Mechanical	Input Power kW	2.13	2.69	7.37	8.78	6.44
				Output Torque Nm	1610.	2220.	5550.	7550.	5350.
				Efficiency %	74	78	81	83	81
			Thermal	Input Power kW	2.58	4.01	6.70	11.20	10.60
				Output Torque Nm	1960.	3340.	5050.	9660.	8900.
				Efficiency %	72	76	76	80	80
	100.	7.25	Mechanical	Input Power kW	1.28	2.44	5.75	7.48	6.44
				Output Torque Nm	1190.	2470.	5740.	8280.	6600.
				Efficiency %	72	76	76	80	80
			Thermal	Input Power kW	2.40	3.44	5.06	8.89	10.60
				Output Torque Nm	2250.	3500.	5050.	9860.	11000.
				Efficiency %	68	71	75	78	80
	125.	5.80	Mechanical	Input Power kW	1.58	2.32	4.46	6.15	6.44
				Output Torque Nm	1770.	2840.	5210.	7960.	8170.
				Efficiency %	69	73	76	79	79
			Thermal	Input Power kW	1.83	2.77	4.61	7.97	7.52
				Output Torque Nm	2050.	3400.	5380.	10400.	9560.
				Efficiency %	67	71	72	76	74
	150.	4.83	Mechanical	Input Power kW	1.26	1.53	4.20	5.15	4.79
				Output Torque Nm	1720.	2360.	5980.	8030.	7590.
				Efficiency %	69	73	76	79	79
			Thermal	Input Power kW	2.25	3.42	5.48	8.68	5.11
				Output Torque Nm	3090.	5360.	7830.	13600.	8100.
				Efficiency %	67	71	72	76	74
	200.	3.63	Mechanical	Input Power kW	0.76	1.39	3.27	4.32	4.51
				Output Torque Nm	1270.	2620.	6130.	8640.	8490.
				Efficiency %	67	71	72	76	74
			Thermal	Input Power kW	2.11	2.95	4.17	7.15	6.64
				Output Torque Nm	3580.	5630.	7820.	14300.	12600.
				Efficiency %	67	71	72	76	74
	225.	3.22	Mechanical	Input Power kW	0.88	1.14	2.94	3.39	3.93
				Output Torque Nm	1710.	2350.	5960.	7980.	8640.
				Efficiency %	63	70	72	75	77
			Thermal	Input Power kW	1.79	3.37	5.23	6.03	5.62
				Output Torque Nm	3530.	7080.	10700.	14300.	12400.
				Efficiency %	63	70	72	75	77
	250.	2.90	Mechanical	Input Power kW	0.86	1.60	2.28	3.68	3.48
				Output Torque Nm	1630.	3350.	4930.	8640.	8640.
				Efficiency %	59	65	67	73	77
			Thermal	Input Power kW	1.18	2.49	3.50	4.14	5.11
				Output Torque Nm	2250.	5270.	7640.	9730.	12700.
				Efficiency %	59	65	67	73	77
	300.	2.42	Mechanical	Input Power kW	0.73	0.88	2.26	2.75	2.98
				Output Torque Nm	1710.	2350.	5940.	7960.	8460.
				Efficiency %	57	67	70	73	72
			Thermal	Input Power kW	1.32	3.33	4.86	5.46	5.67
				Output Torque Nm	3130.	9070.	12900.	15900.	16300.
				Efficiency %	57	67	70	73	72
350.	2.07	Mechanical	Input Power kW	0.35	0.59	1.32	2.14	2.72	
			Output Torque Nm	786.	1550.	3220.	6310.	8450.	
			Efficiency %	48	55	55	62	71	
		Thermal	Input Power kW	0.94	1.45	2.01	3.43	5.50	
			Output Torque Nm	2190.	3980.	4980.	10200.	17300.	
			Efficiency %	48	55	55	62	71	
375.	1.93	Mechanical	Input Power kW	0.62	0.76	1.92	2.25	2.26	
			Output Torque Nm	1710.	2340.	5920.	7940.	7940.	
			Efficiency %	54	60	64	70	71	
		Thermal	Input Power kW	1.18	2.49	3.50	4.14	4.77	
			Output Torque Nm	3330.	7970.	10900.	14700.	17000.	
			Efficiency %	54	60	64	70	71	
400.	1.81	Mechanical	Input Power kW	0.45	0.81	1.79	2.34	2.64	
			Output Torque Nm	1260.	2610.	6130.	8640.	8640.	
			Efficiency %	55	64	65	70	63	
		Thermal	Input Power kW	1.32	2.70	3.62	5.46	3.96	
			Output Torque Nm	3870.	8920.	12500.	20300.	13100.	
			Efficiency %	55	64	65	70	63	
450.	1.61	Mechanical	Input Power kW	0.50	0.97	1.76	2.17	2.12	
			Output Torque Nm	1620.	3330.	6130.	8640.	8430.	
			Efficiency %	55	60	61	65	70	
		Thermal	Input Power kW	1.53	2.10	3.00	4.83	5.04	
			Output Torque Nm	5130.	7390.	10600.	19500.	20300.	
			Efficiency %	55	60	61	65	70	
500.	1.45	Mechanical	Input Power kW	0.56	0.78	1.43	1.97	1.88	
			Output Torque Nm	1890.	3010.	5650.	8420.	8420.	
			Efficiency %	51	60	63	68	69	
		Thermal	Input Power kW	1.32	2.34	3.14	4.98	4.84	
			Output Torque Nm	4540.	9250.	12600.	21600.	22000.	
			Efficiency %	51	60	63	68	69	
600.	1.21	Mechanical	Input Power kW	0.44	0.52	1.30	1.53	1.21	
			Output Torque Nm	1700.	2330.	5900.	7900.	6730.	
			Efficiency %	47	55	59	64	74	
		Thermal	Input Power kW	0.95	1.99	2.76	3.05	2.83	
			Output Torque Nm	3780.	9370.	12700.	16000.	15800.	
			Efficiency %	47	55	59	64	74	
625.	1.16	Mechanical	Input Power kW	0.48	0.68	1.23	1.62	1.63	
			Output Torque Nm	1880.	3010.	5710.	8400.	8410.	
			Efficiency %	48	54	58	64	65	
		Thermal	Input Power kW	1.18	2.46	3.12	4.14	4.73	
			Output Torque Nm	4820.	11400.	14800.	21800.	25100.	
			Efficiency %	48	54	58	64	65	
700.	1.04	Mechanical	Input Power kW	0.34	0.50	0.78	1.14	1.61	
			Output Torque Nm	1260.	2190.	3640.	5870.	8610.	
			Efficiency %	42	49	52	57	60	
		Thermal	Input Power kW	0.49	0.97	1.47	1.88	3.28	
			Output Torque Nm	1900.	4420.	7010.	9800.	17900.	
			Efficiency %	42	49	52	57	60	
750.	0.97	Mechanical	Input Power kW	0.38	0.44	1.10	1.27	1.10	
			Output Torque Nm	1700.	2330.	5880.	7880.	7880.	
			Efficiency %	44	52	55	61	71	
		Thermal	Input Power kW	0.71	1.51	2.23	2.65	3.25	
			Output Torque Nm	3280.	8450.	12100.	16700.	23400.	
			Efficiency %	44	52	55	61	71	
800.	0.91	Mechanical	Input Power kW	0.27	0.48	1.05	1.32	1.34	
			Output Torque Nm	1250.	2590.	6130.	8640.	8640.	
			Efficiency %	44	52	54	61	61	
		Thermal	Input Power kW	0.95	1.99	2.76	3.05	3.49	
			Output Torque Nm	4680.	11300.	16600.	20300.	23000.	
			Efficiency %	44	52	54	61	61	

SERIES AM

RATINGS AT 725 RPM INPUT

	NOMINAL RATIO	NOMINAL OUTPUT SPEED REV / MIN	CAPACITY		SIZE OF UNIT				
					A1002	A1252	A1602	A2002 Reducer	A2002 Motorised
DOUBLE REDUCTION	900.	0.81	Mechanical	Input Power kW	0.33	0.39	0.97	1.11	1.26
				Output Torque Nm	1700.	2320.	5870.	7870.	8590.
				Efficiency %	42	48	52	59	59
			Thermal	Input Power kW	0.62	1.23	1.87	2.24	3.02
				Output Torque Nm	3260.	7780.	11600.	16100.	21000.
				Efficiency %	41	49	52	58	58
	1000.	0.73	Mechanical	Input Power kW	0.34	0.47	0.87	1.11	1.12
				Output Torque Nm	1880.	3000.	5880.	8370.	8590.
				Efficiency %	41	49	52	58	58
			Thermal	Input Power kW	0.95	1.99	2.76	3.05	2.91
				Output Torque Nm	5460.	13500.	19300.	23600.	22800.
				Efficiency %	41	49	52	58	58
	1200.	0.60	Mechanical	Input Power kW	0.26	0.45	0.82	1.01	0.88
				Output Torque Nm	1610.	3300.	6130.	8640.	7720.
				Efficiency %	39	46	48	54	55
			Thermal	Input Power kW	0.95	1.98	2.70	3.05	2.44
				Output Torque Nm	6370.	15300.	21100.	26700.	21900.
				Efficiency %	36	43	45	52	53
	1250.	0.58	Mechanical	Input Power kW	0.30	0.39	0.75	0.93	0.80
				Output Torque Nm	1880.	2990.	5970.	8360.	8360.
				Efficiency %	38	46	49	56	65
			Thermal	Input Power kW	0.71	1.51	2.23	2.65	3.25
				Output Torque Nm	4720.	12200.	18300.	24600.	34500.
				Efficiency %	36	43	46	53	60
	1400.	0.52	Mechanical	Input Power kW	0.20	0.33	0.72	0.89	0.90
				Output Torque Nm	1250.	2580.	6130.	8640.	8570.
				Efficiency %	36	43	45	52	53
			Thermal	Input Power kW	0.49	0.97	1.47	1.88	2.78
				Output Torque Nm	3450.	8050.	12900.	18700.	27600.
				Efficiency %	36	43	45	52	53
	1500.	0.48	Mechanical	Input Power kW	0.26	0.35	0.67	0.81	0.73
				Output Torque Nm	1870.	2990.	6040.	8350.	8640.
				Efficiency %	36	43	46	53	60
			Thermal	Input Power kW	0.62	1.23	1.87	2.24	3.25
				Output Torque Nm	4680.	11200.	17500.	23800.	39000.
				Efficiency %	36	43	46	53	60
	1600.	0.45	Mechanical	Input Power kW	0.24	0.30	0.66	0.81	0.75
				Output Torque Nm	1760.	2630.	6130.	8640.	8560.
				Efficiency %	35	42	44	51	56
			Thermal	Input Power kW	0.95	1.59	2.11	3.05	2.58
				Output Torque Nm	7760.	15600.	20500.	33900.	30100.
				Efficiency %	35	42	44	51	56
1750.	0.41	Mechanical	Input Power kW	0.24	0.33	0.62	0.74	0.72	
			Output Torque Nm	1870.	2990.	6100.	8340.	7710.	
			Efficiency %	33	40	44	50	50	
		Thermal	Input Power kW	0.49	0.97	1.47	1.88	2.34	
			Output Torque Nm	4000.	9560.	15000.	21700.	26500.	
			Efficiency %	33	40	44	50	50	
1800.	0.40	Mechanical	Input Power kW	0.20	0.34	0.62	0.75	0.65	
			Output Torque Nm	1610.	3300.	6130.	8640.	8640.	
			Efficiency %	34	41	42	49	57	
		Thermal	Input Power kW	0.62	1.23	1.87	2.24	2.83	
			Output Torque Nm	5470.	12800.	19500.	26900.	38500.	
			Efficiency %	34	41	42	49	57	
2000.	0.36	Mechanical	Input Power kW	0.21	0.25	0.57	0.68	0.63	
			Output Torque Nm	1750.	2620.	6130.	8640.	8550.	
			Efficiency %	32	40	41	48	51	
		Thermal	Input Power kW	0.71	1.51	2.09	2.65	2.52	
			Output Torque Nm	6700.	17600.	23900.	35300.	35800.	
			Efficiency %	32	40	41	48	51	
2100.	0.35	Mechanical	Input Power kW	0.19	0.32	0.56	0.69	0.54	
			Output Torque Nm	1610.	3290.	6130.	8640.	8640.	
			Efficiency %	31	38	39	46	59	
		Thermal	Input Power kW	0.49	0.97	1.47	1.88	2.89	
			Output Torque Nm	4670.	10900.	16800.	24500.	46900.	
			Efficiency %	31	38	39	46	59	
2400.	0.30	Mechanical	Input Power kW	0.18	0.23	0.50	0.60	0.50	
			Output Torque Nm	1750.	2620.	6130.	8640.	8640.	
			Efficiency %	31	37	39	46	58	
		Thermal	Input Power kW	0.62	1.23	1.87	2.24	2.83	
			Output Torque Nm	6640.	16200.	24200.	34000.	50100.	
			Efficiency %	31	37	39	46	58	
2500.	0.29	Mechanical	Input Power kW	0.15	0.22	0.48	0.57	0.48	
			Output Torque Nm	1430.	2580.	6130.	8540.	8540.	
			Efficiency %	29	36	39	46	54	
		Thermal	Input Power kW	0.71	1.26	1.79	2.63	2.29	
			Output Torque Nm	7990.	17100.	24400.	41600.	41600.	
			Efficiency %	29	36	39	46	54	
2800.	0.26	Mechanical	Input Power kW	0.17	0.21	0.46	0.55	0.48	
			Output Torque Nm	1750.	2620.	6130.	8640.	8530.	
			Efficiency %	28	34	36	43	50	
		Thermal	Input Power kW	0.49	0.97	1.47	1.88	2.35	
			Output Torque Nm	5670.	13800.	20800.	31000.	43700.	
			Efficiency %	28	34	36	43	50	
3000.	0.24	Mechanical	Input Power kW	0.13	0.20	0.43	0.50	0.38	
			Output Torque Nm	1430.	2580.	6130.	8530.	7680.	
			Efficiency %	27	33	36	43	51	
		Thermal	Input Power kW	0.62	1.23	1.79	2.24	1.92	
			Output Torque Nm	7910.	18900.	27600.	40600.	39900.	
			Efficiency %	27	33	36	43	51	
3500.	0.21	Mechanical	Input Power kW	0.13	0.18	0.39	0.46	0.31	
			Output Torque Nm	1430.	2570.	6130.	8520.	7040.	
			Efficiency %	25	31	34	40	49	
		Thermal	Input Power kW	0.49	0.97	1.47	1.88	1.71	
			Output Torque Nm	6750.	16100.	24900.	36900.	39600.	
			Efficiency %	25	31	34	40	49	
3600.	0.20	Mechanical	Input Power kW	0.10	0.16	0.31	0.40	0.36	
			Output Torque Nm	1150.	2220.	4720.	7670.	8520.	
			Efficiency %	24	30	33	40	53	
		Thermal	Input Power kW	0.62	1.11	1.50	2.19	2.13	
			Output Torque Nm	8910.	19400.	26000.	45300.	52000.	
			Efficiency %	24	30	33	40	53	
4200.	0.17	Mechanical	Input Power kW	0.10	0.15	0.28	0.37	0.28	
			Output Torque Nm	1160.	2220.	4760.	7670.	7670.	
			Efficiency %	21	27	30	37	50	
		Thermal	Input Power kW	0.49	0.97	1.47	1.88	1.78	
			Output Torque Nm	7600.	18500.	28000.	42300.	50000.	
			Efficiency %	21	27	30	37	50	

	NOMINAL RATIO	NOMINAL OUTPUT SPEED REV / MIN	CAPACITY		SIZE OF UNIT			
					A1002	A1252	A1602	A2002
SINGLE REDUCTION	5.0	96.00	Mechanical	Input Power kW	9.48	16.40	30.70	51.80
				Output Torque Nm	906.	1570.	2970.	4990.
			Thermal	Input Power kW	8.69	13.90	22.70	39.80
				Output Torque Nm	830.	1330.	2190.	3830.
				Efficiency %	93	94	95	95
			7.5	64.00	Mechanical	Input Power kW	7.38	13.10
	Output Torque Nm	1000.				1780.	3050.	5660.
	Thermal	Input Power kW			7.22	11.50	19.50	34.70
		Output Torque Nm			979.	1580.	2750.	4930.
		Efficiency %			92	93	94	94
	10.0	48.00			Mechanical	Input Power kW	5.96	10.70
			Output Torque Nm	1050.		1900.	3520.	6240.
			Thermal	Input Power kW	6.42	10.00	16.90	30.20
				Output Torque Nm	1130.	1790.	3060.	5510.
				Efficiency %	91	92	93	94
			12.5	38.40	Mechanical	Input Power kW	5.11	9.19
	Output Torque Nm	1120.				2040.	3680.	6630.
	Thermal	Input Power kW			5.47	8.53	14.90	26.60
		Output Torque Nm			1200.	1890.	3330.	6000.
		Efficiency %			89	90	92	93
	15.0	32.00			Mechanical	Input Power kW	4.71	6.55
			Output Torque Nm	1270.		1790.	3990.	6110.
			Thermal	Input Power kW	4.49	7.51	12.80	23.20
				Output Torque Nm	1210.	2060.	3370.	6470.
				Efficiency %	87	89	90	91
			20.0	24.00	Mechanical	Input Power kW	2.89	5.90
	Output Torque Nm	963.				1990.	4210.	6680.
	Thermal	Input Power kW			4.10	6.36	9.52	18.20
		Output Torque Nm			1370.	2140.	3380.	6600.
		Efficiency %			86	87	87	89
	25.0	19.20			Mechanical	Input Power kW	3.52	5.50
			Output Torque Nm	1430.		2280.	3900.	6420.
Thermal			Input Power kW	3.11	5.05	8.56	16.20	
			Output Torque Nm	1260.	2100.	3570.	6920.	
			Efficiency %	81	84	86	88	
30.0			16.00	Mechanical	Input Power kW	2.58	5.18	10.60
	Output Torque Nm	1230.			2510.	5230.	8640.	
	Thermal	Input Power kW		2.86	4.41	6.81	12.80	
		Output Torque Nm		1360.	2140.	3330.	6460.	
		Efficiency %		80	81	82	85	
	40.0	12.00		Mechanical	Input Power kW	2.22	3.22	7.47
Output Torque Nm			1330.		1990.	4680.	7430.	
Thermal			Input Power kW	2.32	3.82	5.71	10.90	
			Output Torque Nm	1390.	2370.	3560.	7080.	
			Efficiency %	75	78	78	82	
50.0			9.60	Mechanical	Input Power kW	1.51	2.65	5.74
	Output Torque Nm	1090.			1960.	4340.	6490.	
	Thermal	Input Power kW		2.09	3.30	5.10	9.34	
		Output Torque Nm		1510.	2450.	3850.	7370.	
		Efficiency %		73	74	76	79	
	60.0	8.00		Mechanical	Input Power kW	1.13	1.98	4.35
Output Torque Nm			924.		1690.	3780.	5840.	
Thermal			Input Power kW	1.86	2.92	4.42	7.72	
			Output Torque Nm	1540.	2510.	3850.	7080.	
			Efficiency %	69	72	73	77	
70.0			6.86	Mechanical	Input Power kW	0.83	1.50	3.15
	Output Torque Nm	729.			1440.	2990.	5340.	
	Thermal	Input Power kW		1.54	2.54	3.63	6.72	
		Output Torque Nm		1390.	2470.	3460.	6980.	
		Efficiency %		63	69	68	74	

SERIES AM

RATINGS AT 480 RPM INPUT

	NOMINAL RATIO	NOMINAL OUTPUT SPEED REV / MIN	CAPACITY		SIZE OF UNIT				
					A1002	A1252	A1602	A2002 Reducer	A2002 Motorised
DOUBLE REDUCTION	75.0	6.40	Mechanical	Input Power kW	1.54	1.94	5.33	6.33	4.26
				Output Torque Nm	1710.	2370.	5930.	8040.	5240.
			Thermal	Input Power kW	2.27	3.50	5.73	8.69	7.70
				Output Torque Nm	2530.	4300.	6370.	11000.	9530.
	100.	4.80	Mechanical	Input Power kW	0.93	1.77	4.18	5.30	4.26
				Output Torque Nm	1270.	2630.	6130.	8640.	6450.
			Thermal	Input Power kW	2.12	3.01	4.34	7.59	7.70
				Output Torque Nm	2930.	4510.	6370.	12400.	11700.
	125.	3.84	Mechanical	Input Power kW	1.16	1.68	3.13	4.46	4.26
				Output Torque Nm	1890.	3030.	5360.	8490.	8000.
			Thermal	Input Power kW	1.62	2.42	3.97	6.54	5.41
				Output Torque Nm	2660.	4380.	6810.	12500.	10200.
	150.	3.20	Mechanical	Input Power kW	0.86	1.03	2.84	3.48	3.32
				Output Torque Nm	1710.	2350.	5950.	7990.	7790.
			Thermal	Input Power kW	2.11	3.25	5.08	6.42	4.01
				Output Torque Nm	4270.	7530.	10700.	14800.	9420.
	200.	2.40	Mechanical	Input Power kW	0.52	0.94	2.23	2.94	3.06
				Output Torque Nm	1270.	2610.	6130.	8640.	8460.
			Thermal	Input Power kW	2.02	2.74	3.78	6.21	5.73
				Output Torque Nm	5050.	7700.	10400.	18300.	16000.
	225.	2.13	Mechanical	Input Power kW	0.60	0.77	1.99	2.30	2.66
				Output Torque Nm	1710.	2340.	5930.	7950.	8640.
			Thermal	Input Power kW	1.55	3.06	4.51	4.49	4.27
				Output Torque Nm	4470.	9460.	13500.	15600.	13900.
	250.	1.92	Mechanical	Input Power kW	0.59	1.09	1.55	2.52	2.36
				Output Torque Nm	1620.	3330.	4880.	8640.	8640.
			Thermal	Input Power kW	1.02	1.88	2.63	3.11	4.01
				Output Torque Nm	2830.	5790.	8370.	10700.	14800.
	300.	1.60	Mechanical	Input Power kW	0.50	0.60	1.54	1.87	2.02
				Output Torque Nm	1700.	2340.	5910.	7920.	8430.
			Thermal	Input Power kW	1.14	2.60	3.85	4.10	4.96
				Output Torque Nm	3960.	10400.	14900.	17500.	21000.
	350.	1.37	Mechanical	Input Power kW	0.25	0.41	0.93	1.50	1.84
				Output Torque Nm	802.	1580.	3280.	6440.	8420.
			Thermal	Input Power kW	0.81	1.23	1.68	2.86	4.81
				Output Torque Nm	2750.	4950.	6030.	12400.	22200.
	375.	1.28	Mechanical	Input Power kW	0.43	0.52	1.31	1.54	1.53
				Output Torque Nm	1700.	2330.	5900.	7900.	7910.
			Thermal	Input Power kW	1.02	1.88	2.63	3.11	3.48
				Output Torque Nm	4180.	8750.	11900.	16100.	18300.
400.	1.20	Mechanical	Input Power kW	0.31	0.55	1.23	1.60	1.80	
			Output Torque Nm	1260.	2600.	6130.	8640.	8610.	
		Thermal	Input Power kW	1.14	2.46	3.26	4.10	3.40	
			Output Torque Nm	4910.	11900.	16500.	22300.	16600.	
450.	1.07	Mechanical	Input Power kW	0.34	0.66	1.21	1.49	1.43	
			Output Torque Nm	1620.	3320.	6130.	8640.	8400.	
		Thermal	Input Power kW	1.44	1.95	2.72	4.33	4.27	
			Output Torque Nm	7050.	10000.	14000.	25400.	25300.	
500.	0.96	Mechanical	Input Power kW	0.39	0.53	0.99	1.34	1.27	
			Output Torque Nm	1880.	3000.	5750.	8390.	8390.	
		Thermal	Input Power kW	1.14	2.22	2.80	4.10	4.01	
			Output Torque Nm	5730.	12800.	16500.	26000.	26800.	
600.	0.80	Mechanical	Input Power kW	0.30	0.36	0.90	1.05	0.88	
			Output Torque Nm	1700.	2320.	5870.	7870.	7220.	
		Thermal	Input Power kW	0.83	1.52	2.10	2.32	2.65	
			Output Torque Nm	4790.	10300.	14000.	17600.	21900.	
625.	0.77	Mechanical	Input Power kW	0.33	0.46	0.87	1.11	1.10	
			Output Torque Nm	1880.	3000.	5850.	8380.	8380.	
		Thermal	Input Power kW	1.02	1.88	2.63	3.11	3.48	
			Output Torque Nm	6030.	12600.	18100.	23800.	27000.	
700.	0.69	Mechanical	Input Power kW	0.24	0.35	0.56	0.82	1.10	
			Output Torque Nm	1300.	2250.	3740.	6020.	8580.	
		Thermal	Input Power kW	0.44	0.75	1.11	1.43	2.89	
			Output Torque Nm	2460.	4930.	7600.	10700.	23000.	
750.	0.64	Mechanical	Input Power kW	0.26	0.30	0.76	0.88	0.74	
			Output Torque Nm	1690.	2320.	5860.	7850.	7850.	
		Thermal	Input Power kW	0.63	1.15	1.66	2.01	2.82	
			Output Torque Nm	4210.	9360.	13000.	18300.	30100.	
800.	0.60	Mechanical	Input Power kW	0.19	0.33	0.73	0.92	0.91	
			Output Torque Nm	1250.	2580.	6130.	8640.	8640.	
		Thermal	Input Power kW	0.83	1.52	2.10	2.32	3.11	
			Output Torque Nm	5930.	12500.	18200.	22300.	29900.	
			Efficiency %	43	50	52	58	59	

SERIES AM

RATINGS AT 480 RPM INPUT

	NOMINAL RATIO	NOMINAL OUTPUT SPEED REV / MIN	CAPACITY		SIZE OF UNIT				
					A1002	A1252	A1602	A2002 Reducer	A2002 Motorised
DOUBLE REDUCTION	900.	0.53	Mechanical	Input Power kW	0.23	0.27	0.67	0.77	0.86
				Output Torque Nm	1690.	2310.	5850.	7840.	8570.
				Efficiency %	40	46	50	56	57
			Thermal	Input Power kW	0.55	0.95	1.40	1.71	2.68
				Output Torque Nm	4200.	8630.	12500.	17700.	27300.
				Efficiency %	38	44	46	49	52
	1000.	0.48	Mechanical	Input Power kW	0.24	0.32	0.62	0.76	0.76
				Output Torque Nm	1870.	2990.	6040.	8350.	8560.
				Efficiency %	40	47	50	56	56
			Thermal	Input Power kW	0.83	1.52	2.10	2.32	2.59
				Output Torque Nm	6880.	14800.	21200.	25900.	29700.
				Efficiency %	38	44	46	49	52
	1200.	0.40	Mechanical	Input Power kW	0.18	0.31	0.56	0.70	0.60
				Output Torque Nm	1610.	3300.	6130.	8640.	7700.
				Efficiency %	38	44	46	49	52
			Thermal	Input Power kW	0.83	1.52	2.10	2.32	2.17
				Output Torque Nm	8040.	17000.	23700.	29300.	28600.
				Efficiency %	38	44	46	49	52
	1250.	0.38	Mechanical	Input Power kW	0.21	0.27	0.54	0.64	0.54
				Output Torque Nm	1870.	2980.	6120.	8330.	8330.
				Efficiency %	37	44	47	53	64
			Thermal	Input Power kW	0.63	1.15	1.66	2.01	2.82
				Output Torque Nm	6040.	13400.	19600.	26900.	44400.
				Efficiency %	37	44	47	53	64
	1400.	0.34	Mechanical	Input Power kW	0.13	0.23	0.50	0.62	0.62
				Output Torque Nm	1250.	2570.	6130.	8630.	8550.
				Efficiency %	34	41	43	49	52
			Thermal	Input Power kW	0.44	0.75	1.11	1.43	2.50
				Output Torque Nm	4470.	8950.	14000.	20400.	36200.
				Efficiency %	34	41	43	49	52
	1500.	0.32	Mechanical	Input Power kW	0.18	0.24	0.47	0.56	0.50
				Output Torque Nm	1870.	2980.	6130.	8320.	8640.
				Efficiency %	35	41	44	51	59
			Thermal	Input Power kW	0.55	0.95	1.40	1.71	2.82
				Output Torque Nm	6010.	12400.	18800.	26000.	50000.
				Efficiency %	35	41	44	51	59
	1600.	0.30	Mechanical	Input Power kW	0.16	0.20	0.46	0.56	0.51
				Output Torque Nm	1750.	2620.	6130.	8640.	8540.
				Efficiency %	34	41	42	48	54
			Thermal	Input Power kW	0.83	1.48	1.95	2.32	2.32
				Output Torque Nm	9760.	21000.	27200.	37100.	39600.
				Efficiency %	34	41	42	48	54
1750.	0.27	Mechanical	Input Power kW	0.17	0.22	0.43	0.52	0.49	
			Output Torque Nm	1870.	2980.	6130.	8310.	7690.	
			Efficiency %	32	38	41	47	49	
		Thermal	Input Power kW	0.44	0.75	1.11	1.43	2.10	
			Output Torque Nm	5170.	10600.	16200.	23700.	34800.	
			Efficiency %	32	38	41	47	49	
1800.	0.27	Mechanical	Input Power kW	0.14	0.24	0.43	0.52	0.44	
			Output Torque Nm	1610.	3290.	6130.	8640.	8640.	
			Efficiency %	33	39	40	46	56	
		Thermal	Input Power kW	0.55	0.95	1.40	1.71	2.56	
			Output Torque Nm	7020.	14100.	20900.	29300.	51100.	
			Efficiency %	33	39	40	46	56	
2000.	0.24	Mechanical	Input Power kW	0.14	0.17	0.39	0.47	0.43	
			Output Torque Nm	1750.	2620.	6130.	8640.	8530.	
			Efficiency %	31	38	39	46	50	
		Thermal	Input Power kW	0.63	1.15	1.66	2.01	2.29	
			Output Torque Nm	8550.	19400.	27200.	38300.	47600.	
			Efficiency %	31	38	39	46	50	
2100.	0.23	Mechanical	Input Power kW	0.13	0.22	0.39	0.48	0.37	
			Output Torque Nm	1610.	3290.	6130.	8640.	8640.	
			Efficiency %	30	36	37	43	57	
		Thermal	Input Power kW	0.44	0.75	1.11	1.43	2.68	
			Output Torque Nm	6030.	12100.	18000.	26600.	64200.	
			Efficiency %	30	36	37	43	57	
2400.	0.20	Mechanical	Input Power kW	0.13	0.16	0.35	0.42	0.34	
			Output Torque Nm	1750.	2610.	6130.	8640.	8640.	
			Efficiency %	29	35	37	43	57	
		Thermal	Input Power kW	0.55	0.95	1.40	1.71	2.65	
			Output Torque Nm	8500.	17900.	26000.	37100.	68900.	
			Efficiency %	29	35	37	43	57	
2500.	0.19	Mechanical	Input Power kW	0.10	0.15	0.33	0.40	0.33	
			Output Torque Nm	1430.	2570.	6130.	8520.	8520.	
			Efficiency %	28	35	37	43	53	
		Thermal	Input Power kW	0.63	1.15	1.66	2.01	2.08	
			Output Torque Nm	10200.	22600.	32400.	45600.	55400.	
			Efficiency %	28	35	37	43	53	
2800.	0.17	Mechanical	Input Power kW	0.12	0.14	0.32	0.39	0.33	
			Output Torque Nm	1750.	2610.	6130.	8640.	8520.	
			Efficiency %	27	33	34	40	49	
		Thermal	Input Power kW	0.44	0.75	1.11	1.43	2.15	
			Output Torque Nm	7300.	15300.	22400.	33600.	58300.	
			Efficiency %	27	33	34	40	49	
3000.	0.16	Mechanical	Input Power kW	0.09	0.13	0.30	0.35	0.26	
			Output Torque Nm	1430.	2570.	6130.	8510.	7660.	
			Efficiency %	27	32	35	41	50	
		Thermal	Input Power kW	0.55	0.95	1.40	1.71	1.74	
			Output Torque Nm	10100.	20800.	30900.	44100.	53100.	
			Efficiency %	27	32	35	41	50	
3500.	0.14	Mechanical	Input Power kW	0.09	0.13	0.27	0.32	0.21	
			Output Torque Nm	1430.	2570.	6130.	8500.	7020.	
			Efficiency %	24	30	32	38	47	
		Thermal	Input Power kW	0.44	0.75	1.11	1.43	1.55	
			Output Torque Nm	8700.	17800.	26700.	40000.	52800.	
			Efficiency %	24	30	32	38	47	
3600.	0.13	Mechanical	Input Power kW	0.07	0.11	0.22	0.28	0.24	
			Output Torque Nm	1180.	2220.	4820.	7660.	8500.	
			Efficiency %	23	29	31	38	51	
		Thermal	Input Power kW	0.55	0.95	1.40	1.71	1.94	
			Output Torque Nm	11400.	23800.	34800.	50500.	69800.	
			Efficiency %	23	29	31	38	51	
4200.	0.11	Mechanical	Input Power kW	0.07	0.10	0.20	0.26	0.19	
			Output Torque Nm	1190.	2220.	4860.	7650.	7650.	
			Efficiency %	21	27	29	35	49	
		Thermal	Input Power kW	0.44	0.75	1.11	1.43	1.63	
			Output Torque Nm	9770.	20400.	30000.	45800.	67000.	
			Efficiency %	21	27	29	35	49	

	NOMINAL RATIO	NOMINAL OUTPUT SPEED REV / MIN	CAPACITY		SIZE OF UNIT			
					A1002	A1252	A1602	A2002
SINGLE REDUCTION	5.0	50.00	Mechanical	Input Power kW	6.27	10.90	20.50	29.90
				Output Torque Nm	1130.	1980.	3740.	5460.
			Thermal	Input Power kW	5.43	8.51	13.60	23.20
				Output Torque Nm	980.	1540.	2480.	4220.
			Efficiency %	92	92	93	93	
	7.5	33.33	Mechanical	Input Power kW	4.86	8.63	12.60	23.50
				Output Torque Nm	1240.	2220.	3350.	6320.
			Thermal	Input Power kW	4.57	7.17	11.90	20.60
				Output Torque Nm	1170.	1850.	3170.	5540.
			Efficiency %	91	91	92	93	
	10.0	25.00	Mechanical	Input Power kW	3.89	7.01	12.20	22.60
				Output Torque Nm	1300.	2350.	4160.	7780.
			Thermal	Input Power kW	4.11	6.31	10.40	18.10
				Output Torque Nm	1370.	2110.	3560.	6220.
			Efficiency %	90	90	91	92	
	12.5	20.00	Mechanical	Input Power kW	3.32	6.00	10.50	18.70
				Output Torque Nm	1370.	2500.	4420.	7950.
			Thermal	Input Power kW	3.53	5.40	9.24	16.10
				Output Torque Nm	1450.	2240.	3890.	6830.
			Efficiency %	88	88	90	91	
	15.0	16.67	Mechanical	Input Power kW	2.90	3.91	9.86	13.00
				Output Torque Nm	1460.	2010.	4880.	6830.
			Thermal	Input Power kW	2.91	4.79	7.96	14.10
				Output Torque Nm	1460.	2460.	3940.	7400.
			Efficiency %	85	87	88	90	
	20.0	12.50	Mechanical	Input Power kW	1.73	3.54	7.69	11.00
				Output Torque Nm	1080.	2220.	5090.	7480.
			Thermal	Input Power kW	2.68	4.09	5.97	11.10
Output Torque Nm				1670.	2570.	3940.	7560.	
		Efficiency %	84	84	84	87		
25.0	10.00	Mechanical	Input Power kW	2.14	3.33	6.02	9.02	
			Output Torque Nm	1600.	2560.	4670.	7190.	
		Thermal	Input Power kW	2.04	3.26	5.41	9.97	
			Output Torque Nm	1530.	2510.	4190.	7950.	
		Efficiency %	79	81	83	85		
30.0	8.33	Mechanical	Input Power kW	1.57	3.15	6.65	9.26	
			Output Torque Nm	1380.	2820.	5990.	8640.	
		Thermal	Input Power kW	1.89	2.87	4.31	7.90	
			Output Torque Nm	1660.	2560.	3870.	7370.	
		Efficiency %	77	78	78	81		
40.0	6.25	Mechanical	Input Power kW	1.36	1.96	4.83	6.96	
			Output Torque Nm	1490.	2240.	5520.	8340.	
		Thermal	Input Power kW	1.55	2.51	3.66	6.81	
			Output Torque Nm	1700.	2870.	4170.	8150.	
		Efficiency %	72	75	75	78		
50.0	5.00	Mechanical	Input Power kW	0.93	1.63	3.69	5.05	
			Output Torque Nm	1220.	2200.	5070.	7290.	
		Thermal	Input Power kW	1.41	2.19	3.31	5.90	
			Output Torque Nm	1860.	2980.	4540.	8520.	
		Efficiency %	69	71	72	76		
60.0	4.17	Mechanical	Input Power kW	0.65	1.21	2.52	3.92	
			Output Torque Nm	969.	1890.	3960.	6550.	
		Thermal	Input Power kW	1.26	1.95	2.87	4.93	
			Output Torque Nm	1900.	3060.	4520.	8260.	
		Efficiency %	65	68	69	73		
70.0	3.57	Mechanical	Input Power kW	0.48	0.86	1.84	3.19	
			Output Torque Nm	762.	1500.	3130.	6000.	
		Thermal	Input Power kW	1.05	1.71	2.37	4.32	
			Output Torque Nm	1710.	3020.	4040.	8160.	
		Efficiency %	59	65	64	70		

SERIES AM

RATINGS AT 250 RPM INPUT

	NOMINAL RATIO	NOMINAL OUTPUT SPEED REV / MIN	CAPACITY		SIZE OF UNIT				
					A1002	A1252	A1602	A2002 Reducer	A2002 Motorised
DOUBLE REDUCTION	75.0	3.33	Mechanical	Input Power kW	0.84	1.04	2.90	3.40	2.22
				Output Torque Nm	1710.	2350.	5960.	7990.	5060
				Efficiency %	69	73	76	78	77
			Thermal	Input Power kW	2.10	3.21	5.07	5.43	4.63
				Output Torque Nm	4320.	7310.	10400.	12800.	10600
				Efficiency %	68	71	71	74	76
	100.	2.50	Mechanical	Input Power kW	0.50	0.95	2.27	2.88	2.22
				Output Torque Nm	1270.	2610.	6130.	8640.	6230
				Efficiency %	68	71	71	74	76
			Thermal	Input Power kW	1.97	2.72	3.76	5.43	4.63
				Output Torque Nm	5020.	7530.	10200.	16300.	13100
				Efficiency %	68	71	71	74	76
	125.	2.00	Mechanical	Input Power kW	0.63	0.91	1.77	2.41	2.22
				Output Torque Nm	1890.	3020.	5560.	8440.	7730
				Efficiency %	62	67	69	73	76
			Thermal	Input Power kW	1.51	2.24	3.23	5.21	3.72
				Output Torque Nm	4550.	7460.	10200.	18300.	13000
				Efficiency %	62	67	69	73	76
	150.	1.67	Mechanical	Input Power kW	0.46	0.55	1.53	1.87	1.85
				Output Torque Nm	1710.	2340.	5920.	7930.	8060
				Efficiency %	65	69	71	74	75
			Thermal	Input Power kW	1.75	2.81	4.02	4.11	3.05
				Output Torque Nm	6510.	12000.	15600.	17500.	13300
				Efficiency %	65	69	71	74	75
	200.	1.25	Mechanical	Input Power kW	0.28	0.51	1.22	1.60	1.65
				Output Torque Nm	1260.	2600.	6130.	8640.	8410
				Efficiency %	63	66	66	71	69
			Thermal	Input Power kW	1.73	2.33	3.15	4.11	4.63
				Output Torque Nm	7980.	12100.	16000.	22300.	23900
				Efficiency %	63	66	66	71	69
	225.	1.11	Mechanical	Input Power kW	0.33	0.42	1.08	1.25	1.43
				Output Torque Nm	1700.	2330.	5890.	7890.	8640
				Efficiency %	59	65	67	70	73
			Thermal	Input Power kW	1.26	2.17	3.01	2.91	3.20
				Output Torque Nm	6660.	12300.	16600.	18500.	19400
				Efficiency %	59	65	67	70	73
	250.	1.00	Mechanical	Input Power kW	0.32	0.60	0.84	1.39	1.27
				Output Torque Nm	1610.	3310.	4820.	8640.	8640
				Efficiency %	54	60	61	66	72
			Thermal	Input Power kW	0.79	1.35	1.78	2.04	3.05
				Output Torque Nm	3990.	7570.	10300.	12800.	20800
				Efficiency %	54	60	61	66	72
	300.	0.83	Mechanical	Input Power kW	0.28	0.32	0.83	1.01	1.09
				Output Torque Nm	1700.	2320.	5880.	7870.	8380
				Efficiency %	52	62	65	68	67
			Thermal	Input Power kW	0.89	1.86	2.60	2.68	3.72
				Output Torque Nm	5610.	13600.	18500.	21100.	29000
				Efficiency %	52	62	65	68	67
350.	0.71	Mechanical	Input Power kW	0.14	0.23	0.54	0.86	0.99	
			Output Torque Nm	832.	1640.	3400.	6690.	8370	
			Efficiency %	44	50	49	56	67	
		Thermal	Input Power kW	0.68	1.02	1.36	2.29	3.57	
			Output Torque Nm	4140.	7450.	8740.	18100.	30400	
			Efficiency %	44	50	49	56	67	
375.	0.67	Mechanical	Input Power kW	0.23	0.28	0.72	0.84	0.82	
			Output Torque Nm	1690.	2320.	5860.	7850.	7850	
			Efficiency %	49	55	58	64	66	
		Thermal	Input Power kW	0.79	1.35	1.78	2.04	2.44	
			Output Torque Nm	5860.	11400.	14700.	19200.	23600	
			Efficiency %	49	55	58	64	66	
400.	0.63	Mechanical	Input Power kW	0.17	0.30	0.67	0.88	0.99	
			Output Torque Nm	1250.	2580.	6130.	8640.	8580	
			Efficiency %	50	59	60	65	58	
		Thermal	Input Power kW	0.89	1.86	2.60	2.68	2.79	
			Output Torque Nm	6950.	16500.	24000.	26700.	24800	
			Efficiency %	50	59	60	65	58	
450.	0.56	Mechanical	Input Power kW	0.19	0.36	0.66	0.82	0.77	
			Output Torque Nm	1610.	3300.	6130.	8640.	8360	
			Efficiency %	50	55	56	59	66	
		Thermal	Input Power kW	1.26	1.70	2.34	2.91	3.20	
			Output Torque Nm	11200.	15900.	21800.	31000.	35000	
			Efficiency %	50	55	56	59	66	
500.	0.50	Mechanical	Input Power kW	0.21	0.29	0.57	0.73	0.68	
			Output Torque Nm	1870.	2990.	6010.	8350.	8350	
			Efficiency %	46	55	58	63	65	
		Thermal	Input Power kW	0.89	1.86	2.40	2.68	3.05	
			Output Torque Nm	8070.	19600.	25700.	31100.	37700	
			Efficiency %	46	55	58	63	65	
600.	0.42	Mechanical	Input Power kW	0.17	0.20	0.49	0.58	0.53	
			Output Torque Nm	1690.	2310.	5840.	7820.	8210	
			Efficiency %	43	50	53	57	71	
		Thermal	Input Power kW	0.65	1.11	1.45	1.55	2.42	
			Output Torque Nm	6800.	13600.	17400.	21200.	37400	
			Efficiency %	43	50	53	57	71	
625.	0.40	Mechanical	Input Power kW	0.18	0.26	0.50	0.61	0.60	
			Output Torque Nm	1870.	2990.	6110.	8330.	8330	
			Efficiency %	43	49	52	58	61	
		Thermal	Input Power kW	0.79	1.35	1.78	2.04	2.44	
			Output Torque Nm	8410.	16400.	22100.	28300.	34800	
			Efficiency %	43	49	52	58	61	
700.	0.36	Mechanical	Input Power kW	0.14	0.20	0.32	0.48	0.60	
			Output Torque Nm	1350.	2330.	3870.	6230.	8550	
			Efficiency %	38	44	46	50	55	
		Thermal	Input Power kW	0.38	0.56	0.77	0.98	2.42	
			Output Torque Nm	3910.	6600.	9500.	13000.	35300	
			Efficiency %	38	44	46	50	55	
750.	0.33	Mechanical	Input Power kW	0.15	0.17	0.42	0.49	0.40	
			Output Torque Nm	1690.	2310.	5830.	7810.	7810	
			Efficiency %	39	47	49	55	68	
		Thermal	Input Power kW	0.54	0.85	1.15	1.36	2.55	
			Output Torque Nm	6580.	12400.	16100.	22100.	50600	
			Efficiency %	39	47	49	55	68	
800.	0.31	Mechanical	Input Power kW	0.10	0.18	0.40	0.51	0.50	
			Output Torque Nm	1250.	2570.	6130.	8630.	8640	
			Efficiency %	41	48	48	54	57	
		Thermal	Input Power kW	0.65	1.11	1.45	1.55	2.64	
			Output Torque Nm	8420.	16400.	22500.	26700.	46600	
			Efficiency %	41	48	48	54	57	

SERIES AM

RATINGS AT 250 RPM INPUT

	NOMINAL RATIO	NOMINAL OUTPUT SPEED REV / MIN	CAPACITY		SIZE OF UNIT				
					A1002	A1252	A1602	A2002 Reducer	A2002 Motorised
DOUBLE REDUCTION	900.	0.28	Mechanical	Input Power kW	0.13	0.15	0.37	0.43	0.47
				Output Torque Nm	1680.	2300.	5830.	7800.	8540.
				Efficiency %	37	44	47	52	54
			Thermal	Input Power kW	0.48	0.70	0.97	1.16	2.27
				Output Torque Nm	6590.	11500.	15500.	21600.	42300.
				Efficiency %	37	44	47	52	54
	1000.	0.25	Mechanical	Input Power kW	0.13	0.18	0.35	0.42	0.41
				Output Torque Nm	1870.	2980.	6130.	8310.	8530.
				Efficiency %	37	44	47	52	54
			Thermal	Input Power kW	0.65	1.11	1.45	1.55	2.20
				Output Torque Nm	9720.	19400.	26100.	31100.	46200.
				Efficiency %	37	44	47	52	54
	1200.	0.21	Mechanical	Input Power kW	0.10	0.17	0.32	0.39	0.33
				Output Torque Nm	1600.	3290.	6130.	8640.	7670.
				Efficiency %	35	42	42	48	51
			Thermal	Input Power kW	0.65	1.11	1.45	1.55	1.84
				Output Torque Nm	11300.	22200.	29000.	34900.	44400.
				Efficiency %	35	42	42	48	51
	1250.	0.20	Mechanical	Input Power kW	0.11	0.15	0.30	0.36	0.29
				Output Torque Nm	1870.	2970.	6130.	8290.	8300.
				Efficiency %	34	42	44	50	62
			Thermal	Input Power kW	0.54	0.85	1.15	1.36	2.55
				Output Torque Nm	9390.	17700.	24200.	32500.	74200.
				Efficiency %	34	42	44	50	62
	1400.	0.18	Mechanical	Input Power kW	0.07	0.13	0.28	0.35	0.34
				Output Torque Nm	1240.	2560.	6130.	8600.	8520.
				Efficiency %	32	39	40	45	49
			Thermal	Input Power kW	0.38	0.56	0.77	0.98	2.16
				Output Torque Nm	7060.	12000.	17300.	24500.	56900.
				Efficiency %	32	39	40	45	49
	1500.	0.17	Mechanical	Input Power kW	0.10	0.14	0.27	0.31	0.27
				Output Torque Nm	1860.	2970.	6130.	8290.	8640.
				Efficiency %	32	38	41	47	57
			Thermal	Input Power kW	0.48	0.70	0.97	1.16	2.55
				Output Torque Nm	9400.	16400.	23200.	31600.	83200.
				Efficiency %	32	38	41	47	57
	1600.	0.16	Mechanical	Input Power kW	0.09	0.11	0.26	0.31	0.28
				Output Torque Nm	1750.	2610.	6130.	8640.	8510.
				Efficiency %	32	38	39	45	52
			Thermal	Input Power kW	0.65	1.11	1.45	1.55	2.00
				Output Torque Nm	13700.	28000.	36000.	44200.	62500.
				Efficiency %	32	38	39	45	52
1750.	0.14	Mechanical	Input Power kW	0.09	0.13	0.24	0.29	0.27	
			Output Torque Nm	1860.	2970.	6130.	8280.	7660.	
			Efficiency %	30	36	38	43	46	
		Thermal	Input Power kW	0.38	0.56	0.77	0.98	1.81	
			Output Torque Nm	8130.	14100.	20100.	28500.	54600.	
			Efficiency %	30	36	38	43	46	
1800.	0.14	Mechanical	Input Power kW	0.08	0.13	0.24	0.29	0.24	
			Output Torque Nm	1600.	3280.	6130.	8640.	8640.	
			Efficiency %	31	36	37	43	54	
		Thermal	Input Power kW	0.48	0.70	0.97	1.16	2.21	
			Output Torque Nm	11000.	18600.	25700.	35400.	81500.	
			Efficiency %	31	36	37	43	54	
2000.	0.13	Mechanical	Input Power kW	0.08	0.09	0.22	0.27	0.23	
			Output Torque Nm	1750.	2610.	6130.	8640.	8500.	
			Efficiency %	29	36	36	43	48	
		Thermal	Input Power kW	0.54	0.85	1.15	1.36	1.99	
			Output Torque Nm	13200.	25500.	33300.	46000.	75700.	
			Efficiency %	29	36	36	43	48	
2100.	0.12	Mechanical	Input Power kW	0.07	0.12	0.22	0.27	0.20	
			Output Torque Nm	1600.	3280.	6130.	8640.	8640.	
			Efficiency %	28	34	35	39	55	
		Thermal	Input Power kW	0.38	0.56	0.77	0.98	2.44	
			Output Torque Nm	9490.	16100.	22300.	31900.	108000.	
			Efficiency %	28	34	35	39	55	
2400.	0.10	Mechanical	Input Power kW	0.07	0.09	0.20	0.23	0.18	
			Output Torque Nm	1740.	2610.	6130.	8640.	8640.	
			Efficiency %	28	33	34	40	55	
		Thermal	Input Power kW	0.48	0.70	0.97	1.16	2.42	
			Output Torque Nm	13200.	23600.	31900.	44700.	117000.	
			Efficiency %	28	33	34	40	55	
2500.	0.10	Mechanical	Input Power kW	0.06	0.08	0.19	0.22	0.18	
			Output Torque Nm	1420.	2570.	6130.	8490.	8490.	
			Efficiency %	27	33	34	40	51	
		Thermal	Input Power kW	0.54	0.85	1.15	1.36	1.80	
			Output Torque Nm	15800.	29700.	39600.	54700.	88700.	
			Efficiency %	27	33	34	40	51	
2800.	0.09	Mechanical	Input Power kW	0.06	0.08	0.18	0.22	0.18	
			Output Torque Nm	1740.	2600.	6130.	8640.	8490.	
			Efficiency %	25	31	32	37	47	
		Thermal	Input Power kW	0.38	0.56	0.77	0.98	1.88	
			Output Torque Nm	11500.	20300.	27600.	40300.	93200.	
			Efficiency %	25	31	32	37	47	
3000.	0.08	Mechanical	Input Power kW	0.05	0.07	0.17	0.20	0.14	
			Output Torque Nm	1420.	2560.	6130.	8480.	7640.	
			Efficiency %	25	30	32	38	48	
		Thermal	Input Power kW	0.48	0.70	0.97	1.16	1.51	
			Output Torque Nm	15800.	27400.	38000.	53100.	85000.	
			Efficiency %	25	30	32	38	48	
3500.	0.07	Mechanical	Input Power kW	0.05	0.07	0.15	0.18	0.12	
			Output Torque Nm	1420.	2560.	6130.	8480.	7000.	
			Efficiency %	23	28	30	35	46	
		Thermal	Input Power kW	0.38	0.56	0.77	0.98	1.35	
			Output Torque Nm	13600.	23600.	32900.	47900.	84500.	
			Efficiency %	23	28	30	35	46	
3600.	0.07	Mechanical	Input Power kW	0.04	0.06	0.12	0.16	0.13	
			Output Torque Nm	1220.	2210.	4980.	7630.	8480.	
			Efficiency %	23	28	29	35	49	
		Thermal	Input Power kW	0.48	0.70	0.97	1.16	1.70	
			Output Torque Nm	17700.	31400.	42600.	60700.	113000.	
			Efficiency %	23	28	29	35	49	
4200.	0.06	Mechanical	Input Power kW	0.04	0.05	0.12	0.15	0.10	
			Output Torque Nm	1230.	2210.	5010.	7630.	7630.	
			Efficiency %	20	25	27	32	47	
		Thermal	Input Power kW	0.38	0.56	0.77	0.98	1.42	
			Output Torque Nm	15300.	27000.	36900.	54700.	108000.	
			Efficiency %	20	25	27	32	47	

H SHAFT MOUNTED UNIT

A1002 Under Driven

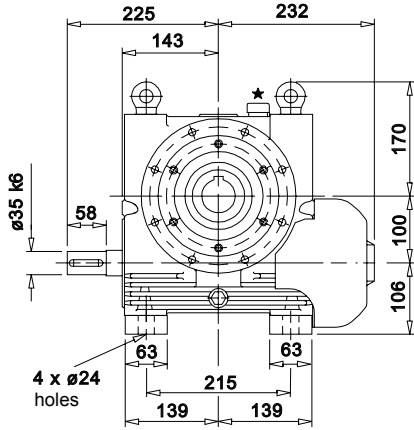

★ COMBINED DIPSTICK VENTILATOR AND OIL FILLER

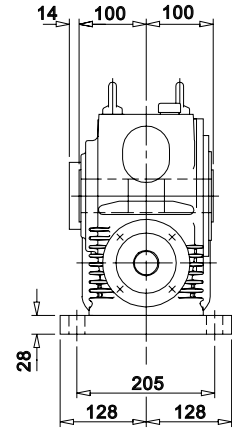
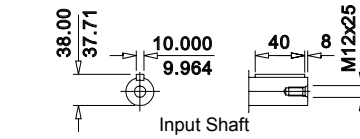
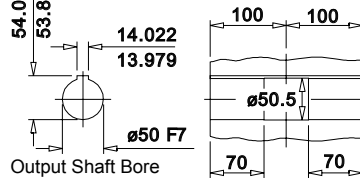

A1002 Over Driven

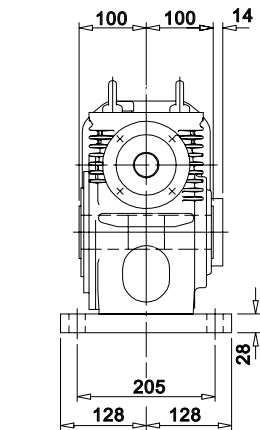
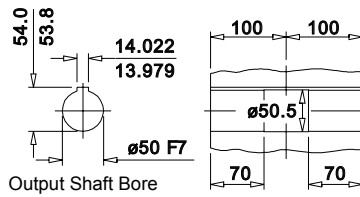
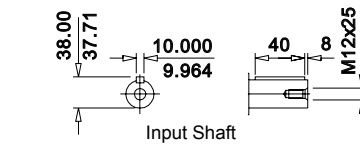
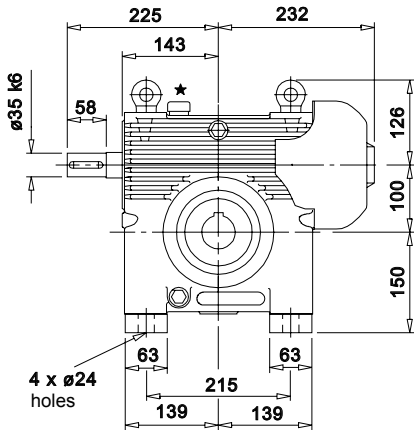

A1002 Output Flange

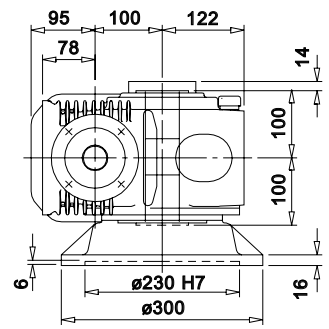
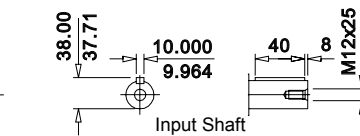
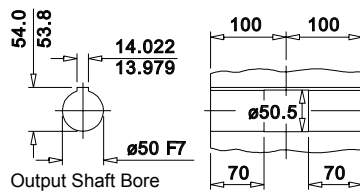
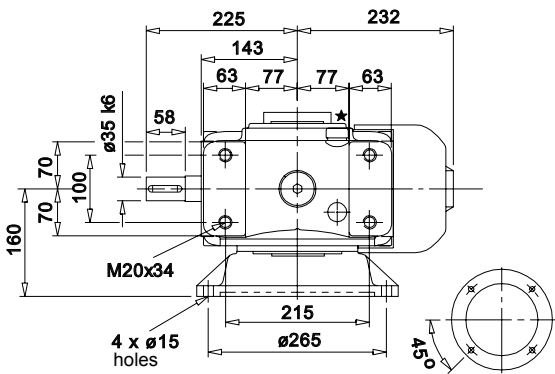

A1002 CR Cooling Tower

* DIMENSIONS TO CUSTOMERS REQUIREMENTS TO SUIT FAN HUBS

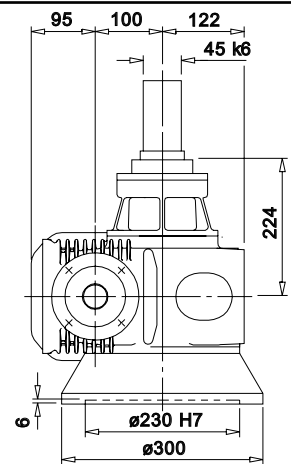
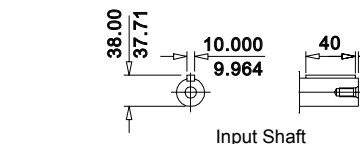
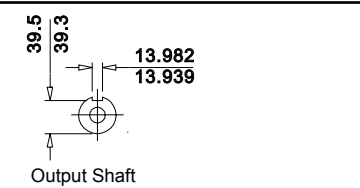
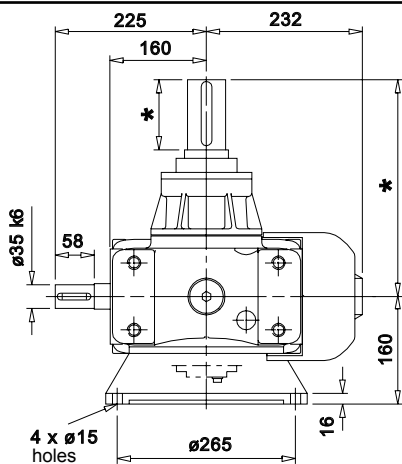

C or E FOR SINGLE EXTENSION OUTPUT SHAFT

D DOUBLE EXTENSION OUTPUT SHAFT

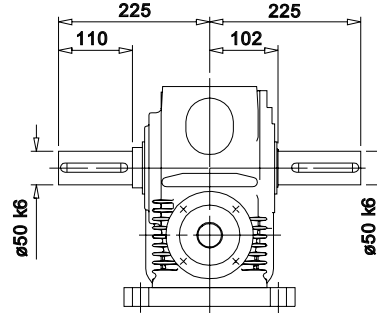
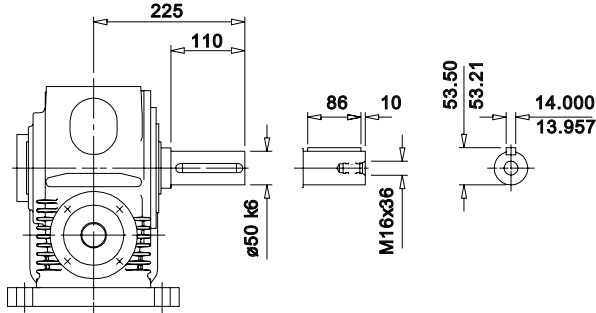

Under Driven

A 1 0 0 2 R

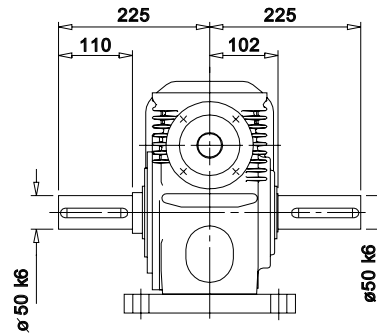
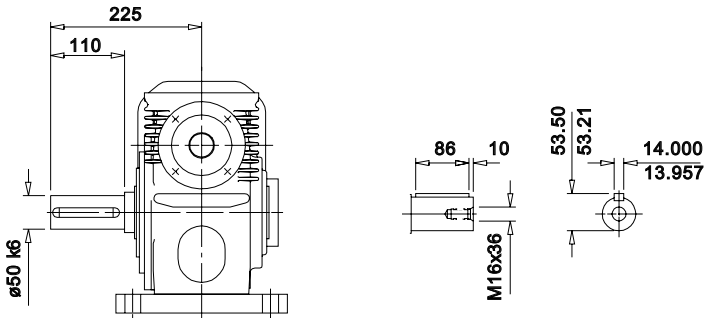

Over Driven

A 1 0 0 2 R

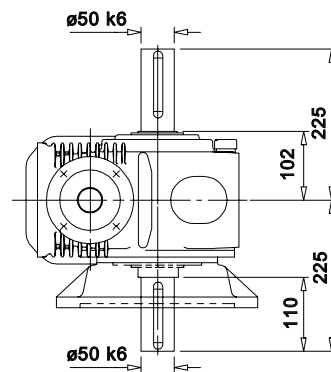
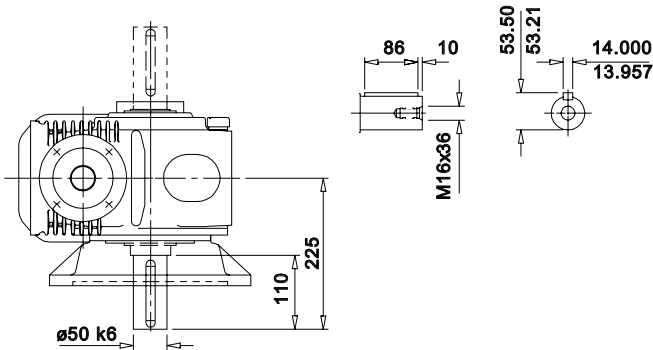

Output Flange

A 1 0 0 2 R

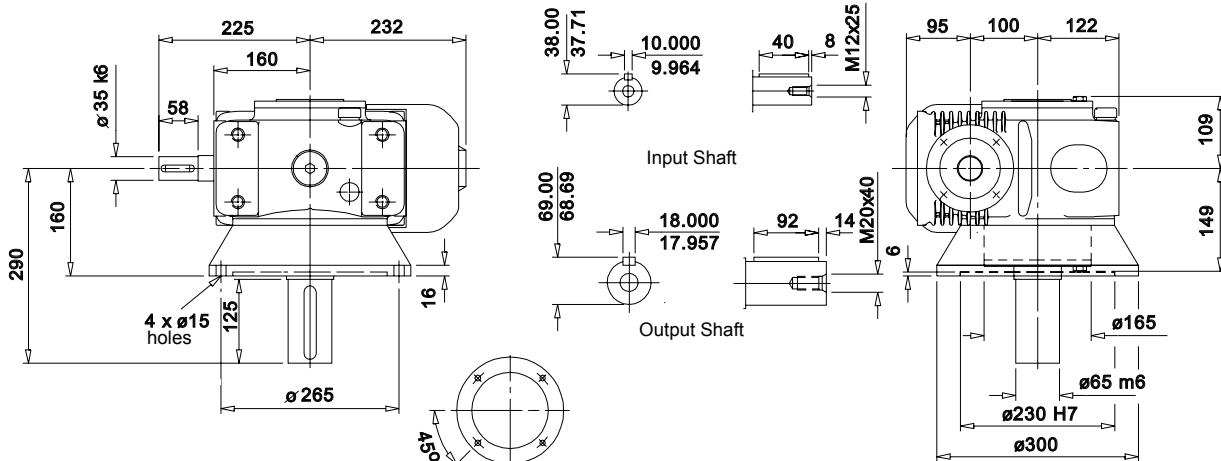

Agitator

A 1 0 0 2 A R

H SHAFT MOUNTED UNIT

A 1 2 5 2 R Under Driven

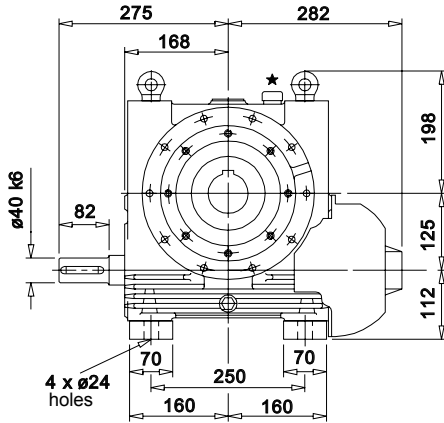

★ COMBINED DIPSTICK VENTILATOR AND OIL FILLER

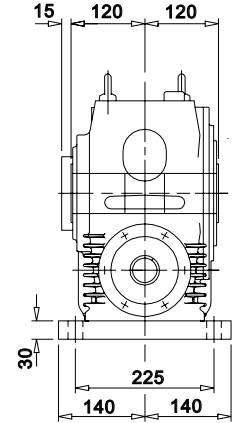
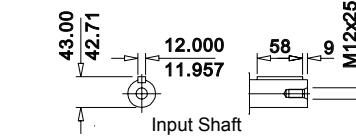
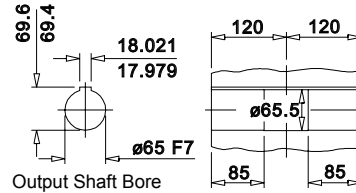

A 1 2 5 2 R Over Driven

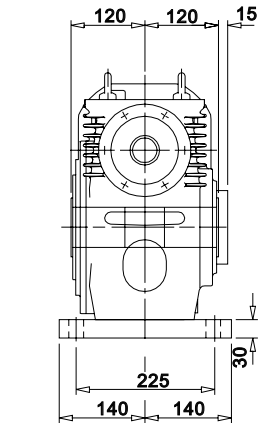
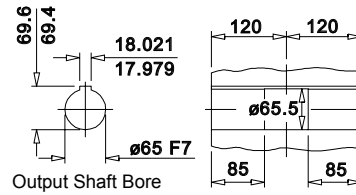
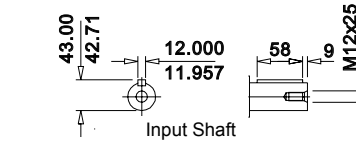
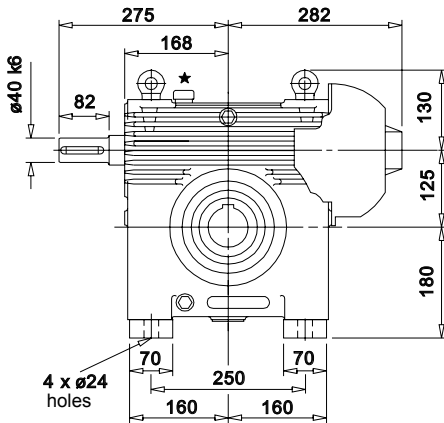

A 1 2 5 2 R Output Flange

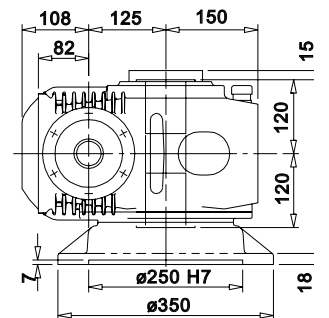
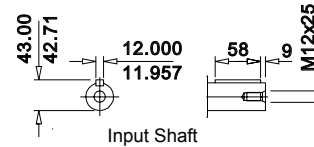
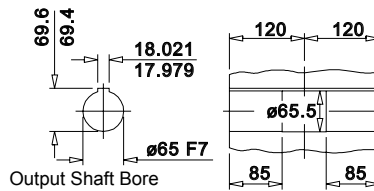
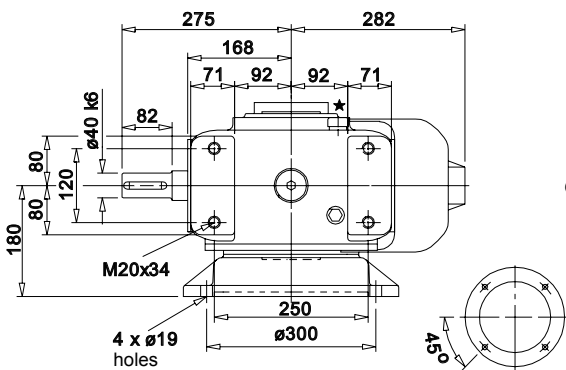

A 1 2 5 2 CR Cooling Tower

* DIMENSIONS TO CUSTOMERS REQUIREMENTS TO SUIT FAN HUBS

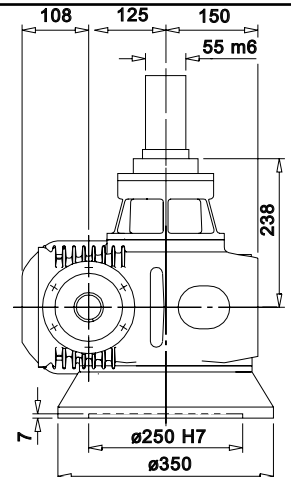
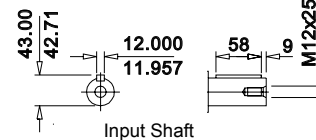
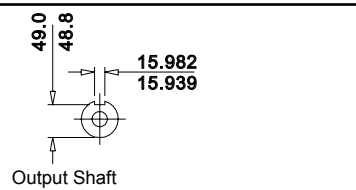
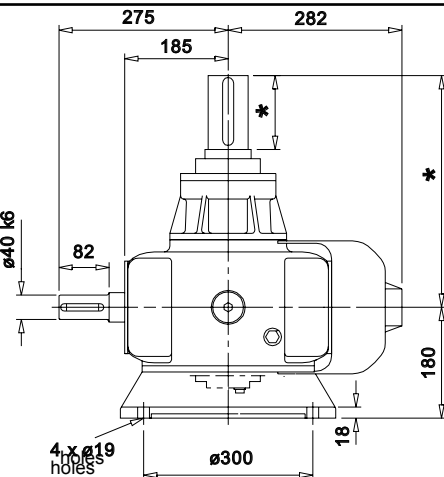

C or E FOR SINGLE EXTENSION OUTPUT SHAFT

D DOUBLE EXTENSION OUTPUT SHAFT

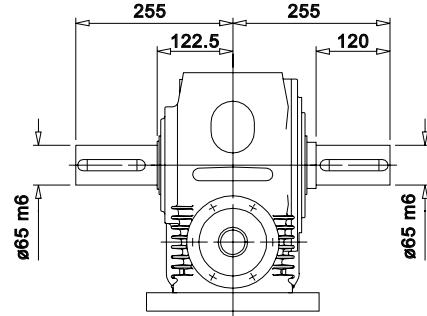
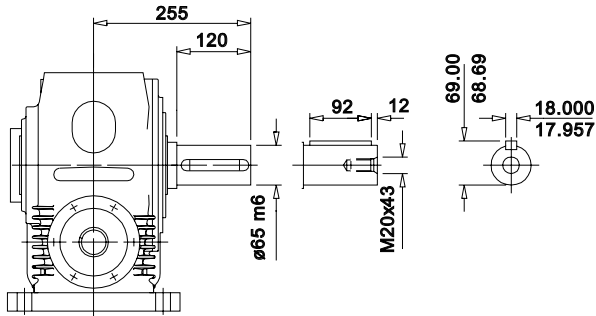

Under Driven

A 1 2 5 2 R

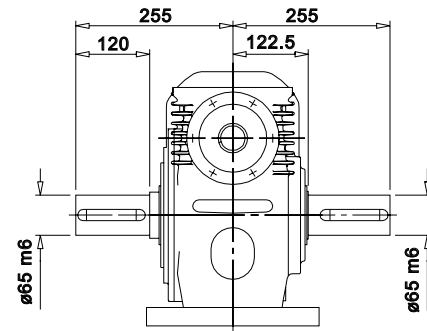
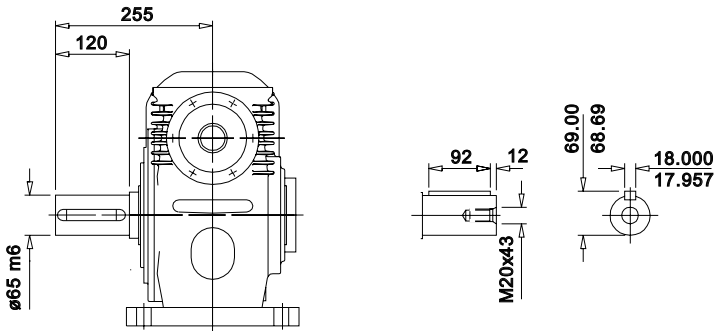

Over Driven

A 1 2 5 2 R

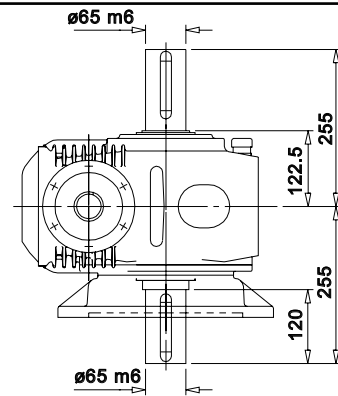
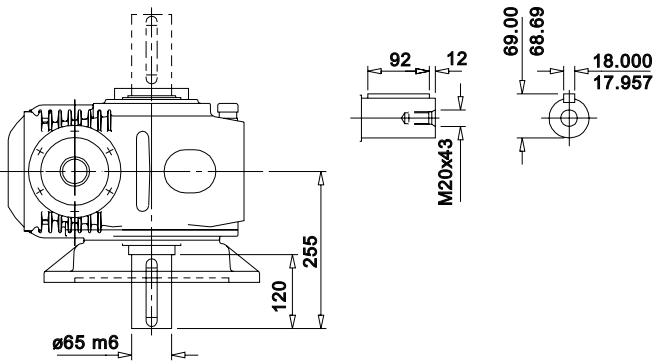

Output Flange

A 1 2 5 2 R

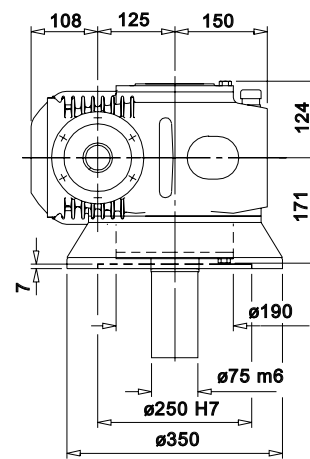
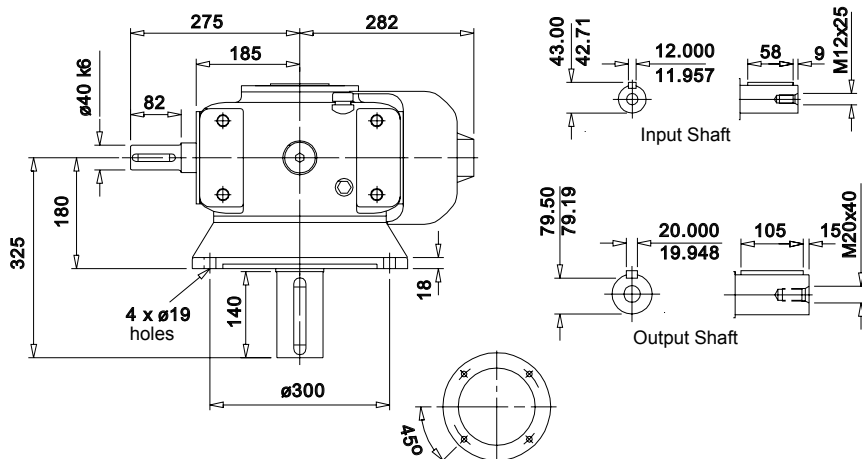

Agitator

A 1 2 5 2 A R

H SHAFT MOUNTED UNIT

A 1 6 0 2 Under Driven

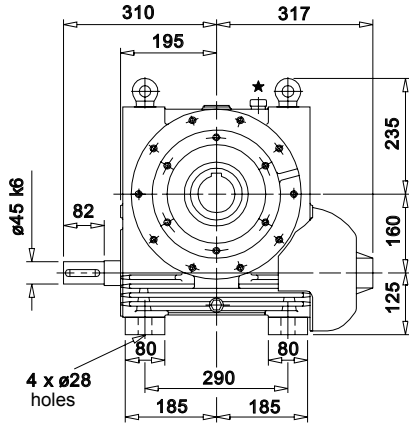

★ COMBINED DIPSTICK VENTILATOR AND OIL FILLER

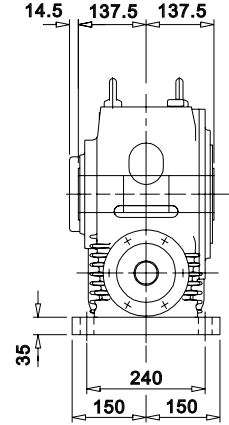
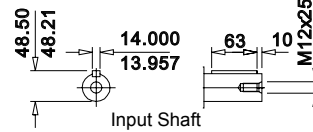
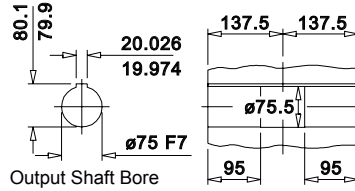

A 1 6 0 2 Over Driven

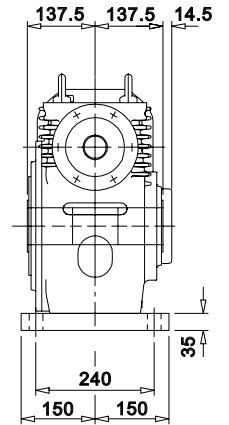
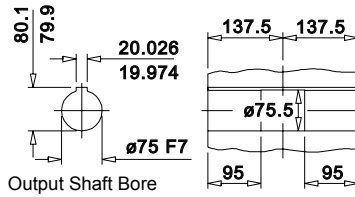
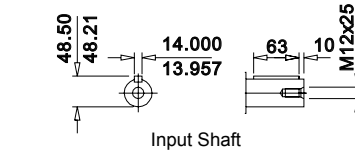
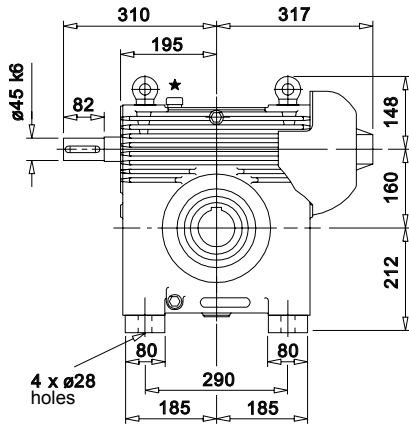

A 1 6 0 2 Output Flange

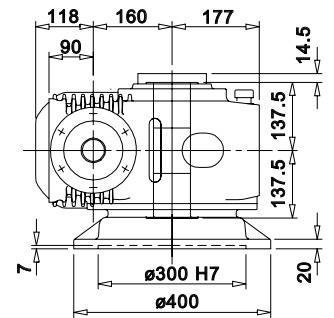
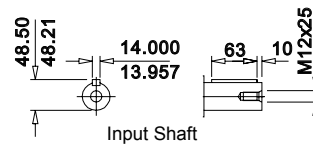
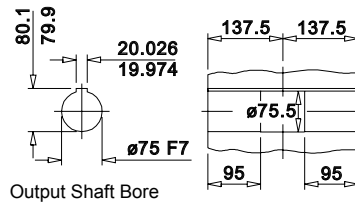
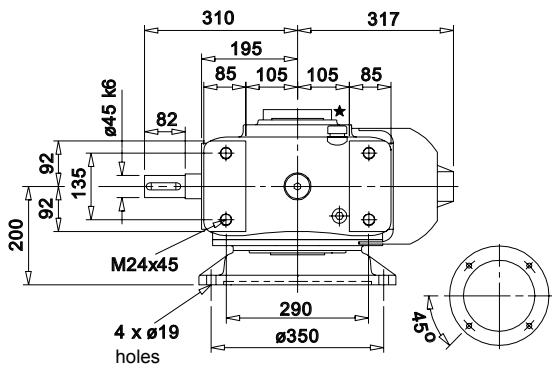

A 1 6 0 2 CR Cooling Tower

* DIMENSIONS TO CUSTOMERS REQUIREMENTS TO SUIT FAN HUBS

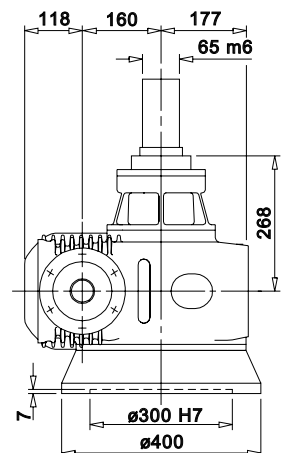
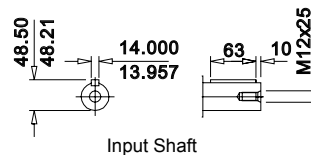
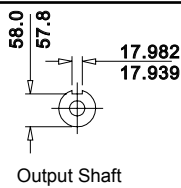
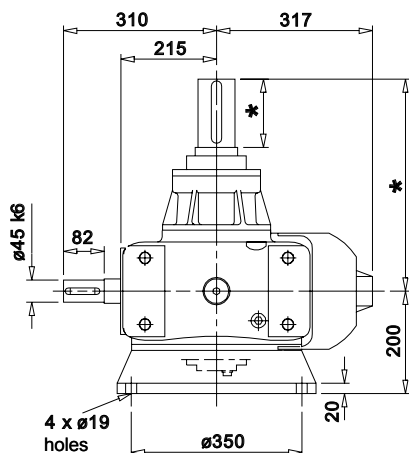

C or E FOR SINGLE EXTENSION OUTPUT SHAFT

D DOUBLE EXTENSION OUTPUT SHAFT

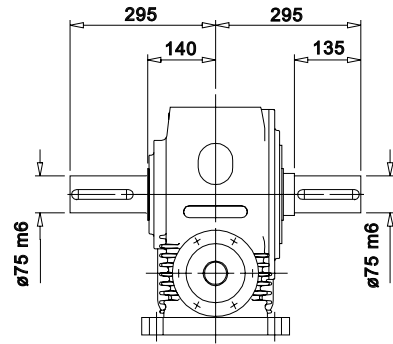
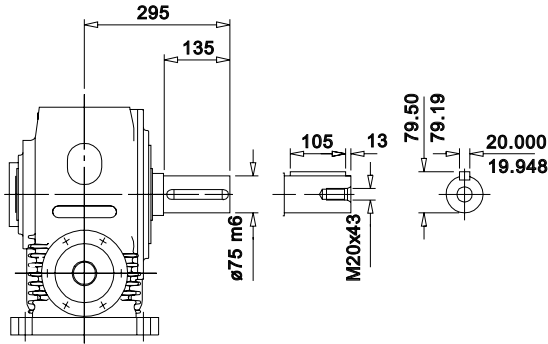

Under Driven

A 1 6 0 2 R

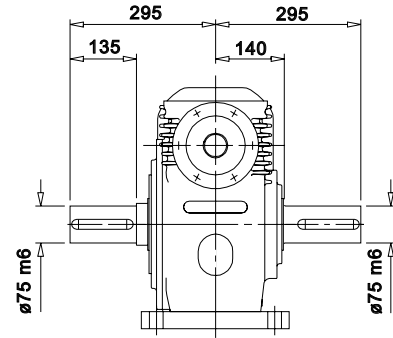
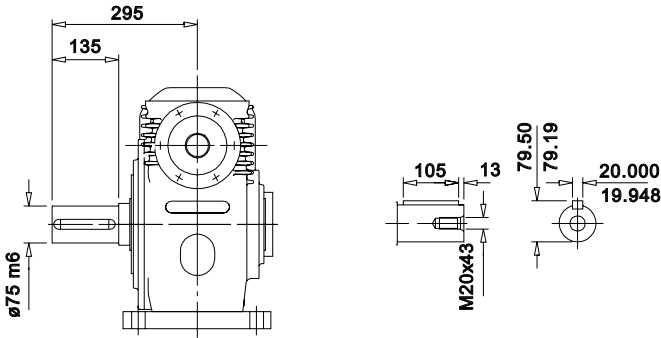

Over Driven

A 1 6 0 2 R

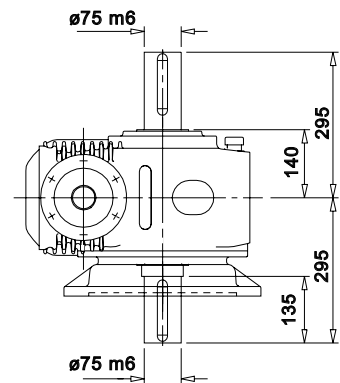
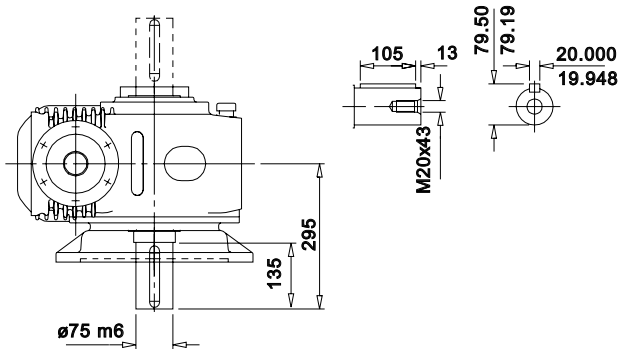

Output Flange

A 1 6 0 2 R

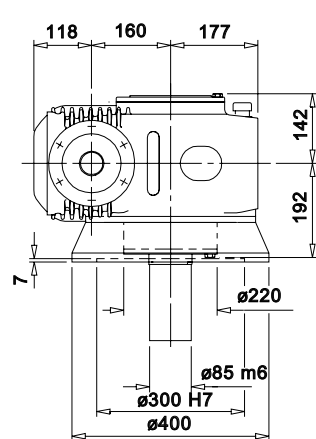
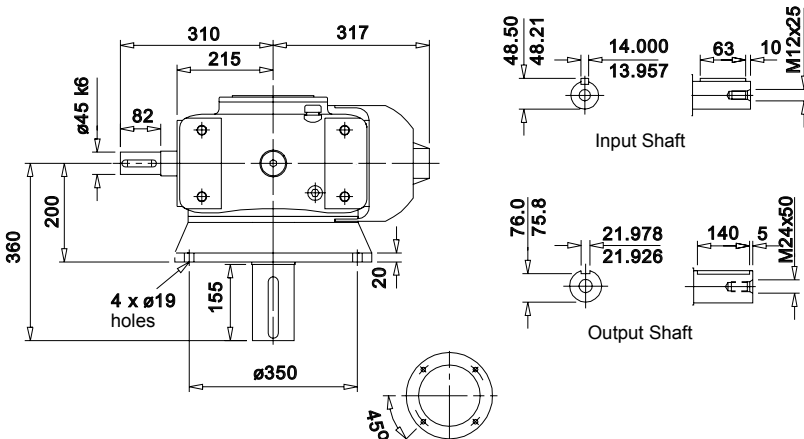

Agitator

A 1 6 0 2 A R

H SHAFT MOUNTED UNIT

A 2 0 0 2 Under Driven

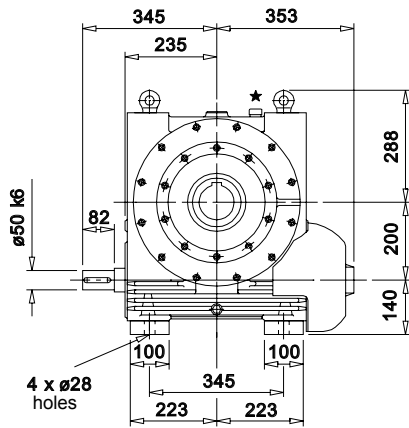

★ COMBINED DIPSTICK VENTILATOR AND OIL FILLER

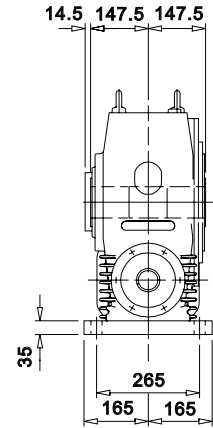
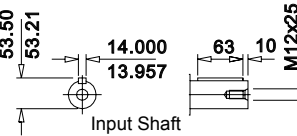
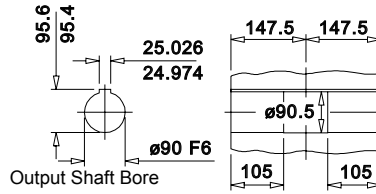

A 2 0 0 2 Over Driven

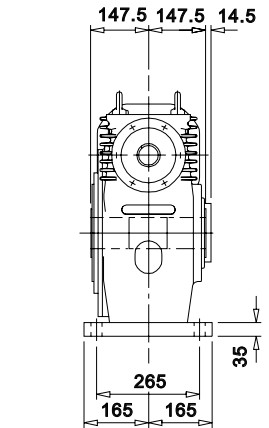
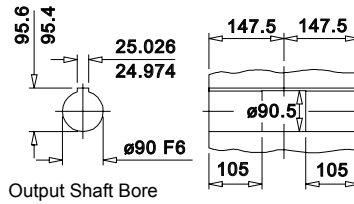
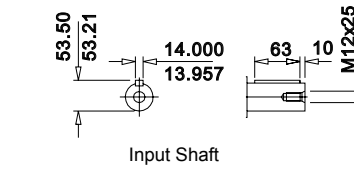
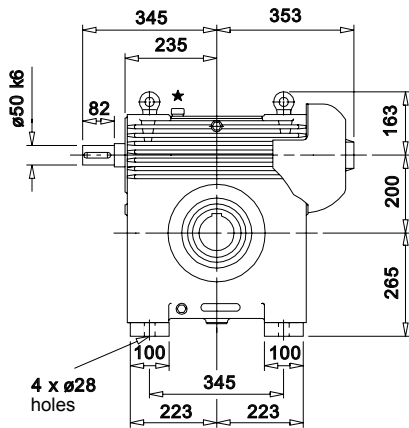

A 2 0 0 2 Output Flange

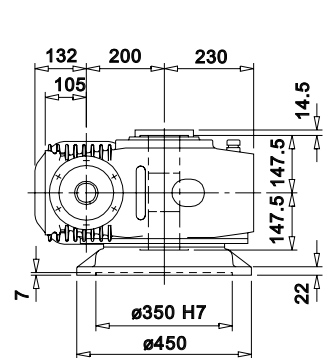
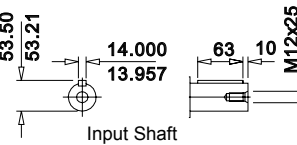
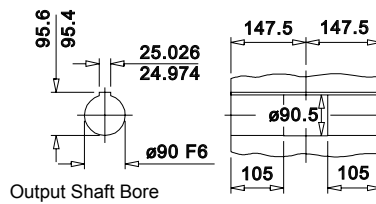
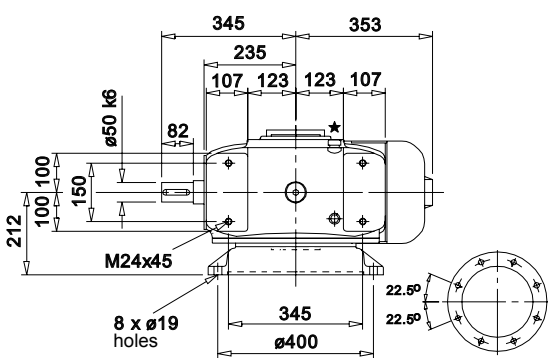

A 2 0 0 2 CR Cooling Tower

* DIMENSIONS TO CUSTOMERS REQUIREMENTS TO SUIT FAN HUBS

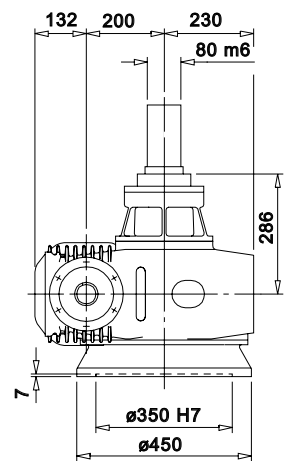
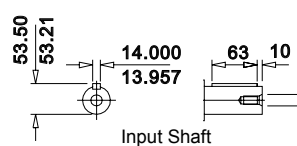
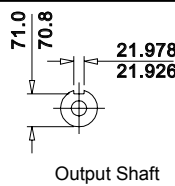
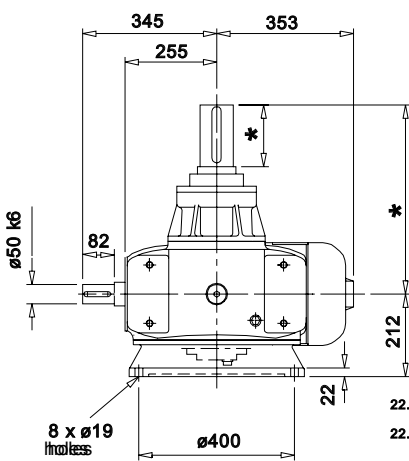

C or E FOR SINGLE EXTENSION OUTPUT SHAFT

D DOUBLE EXTENSION OUTPUT SHAFT

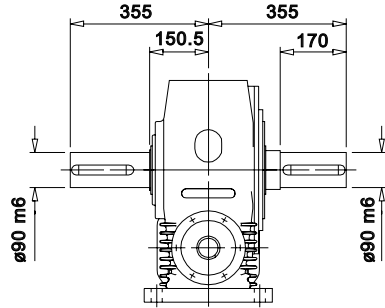
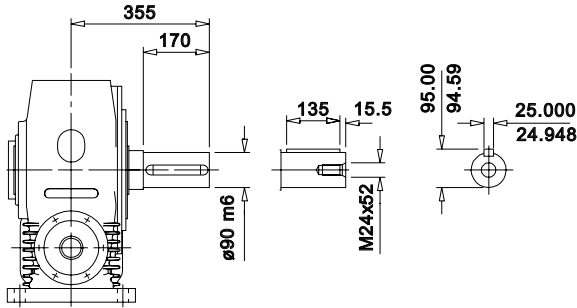

Under Driven

A 2 0 0 2 R

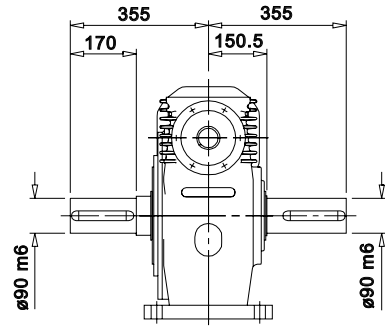
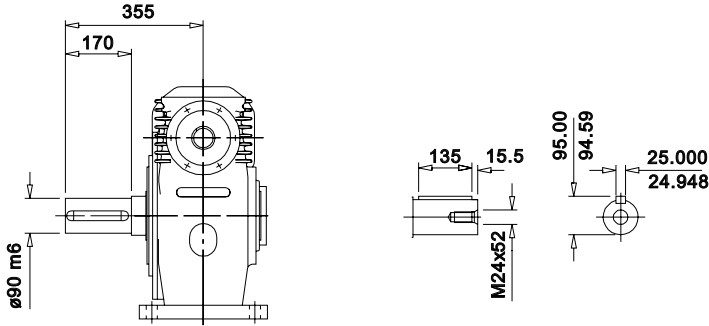

Over Driven

A 2 0 0 2 R

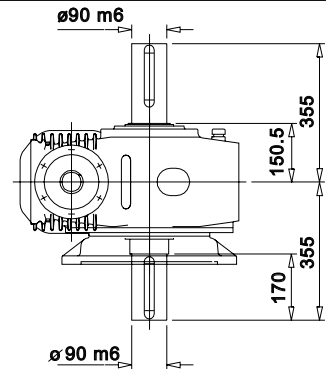
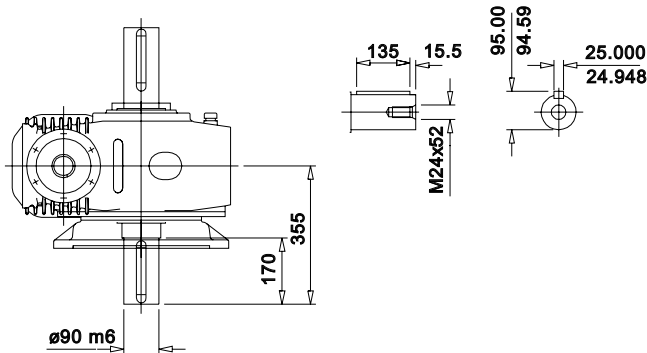

Output Flange

A 2 0 0 2 R

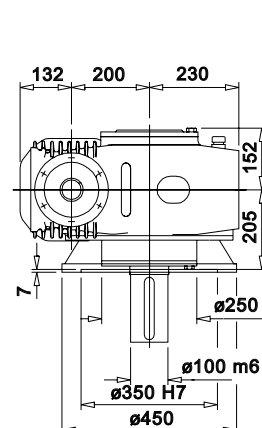
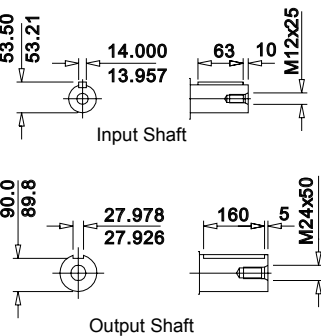
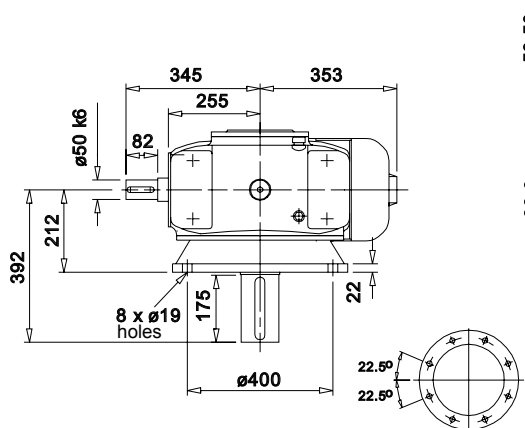

Agitator

A 2 0 0 2 A R

H SHAFT MOUNTED UNIT

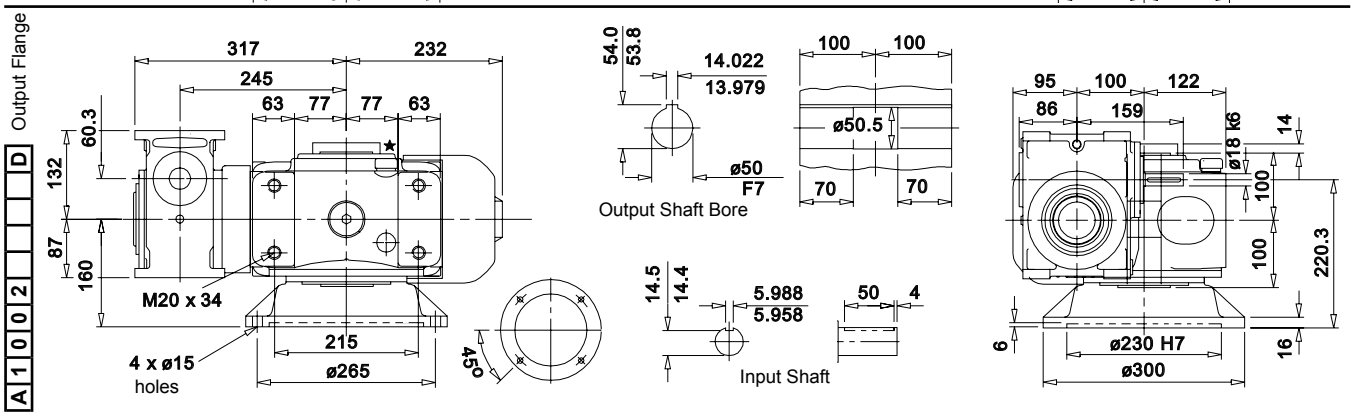
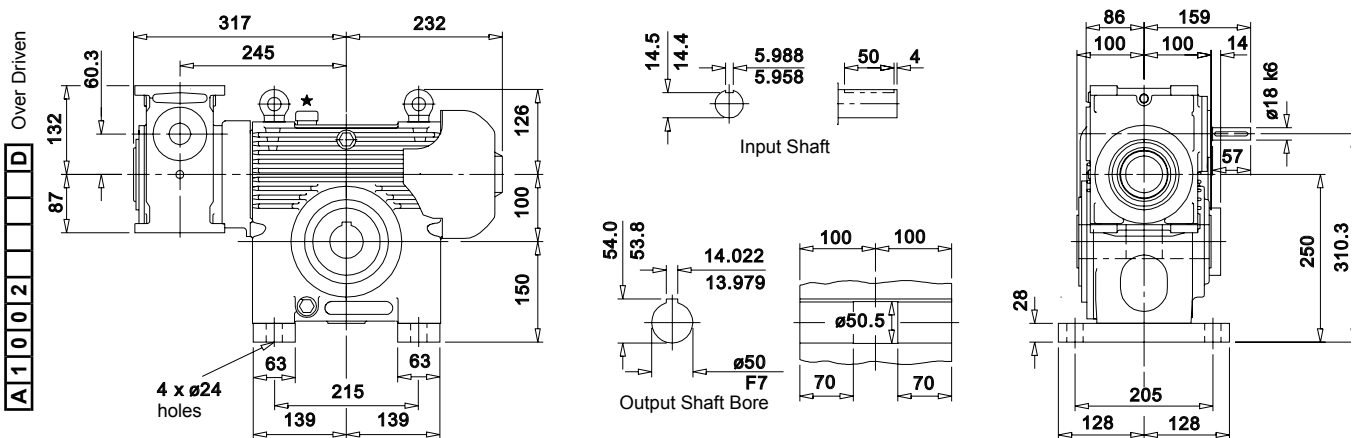
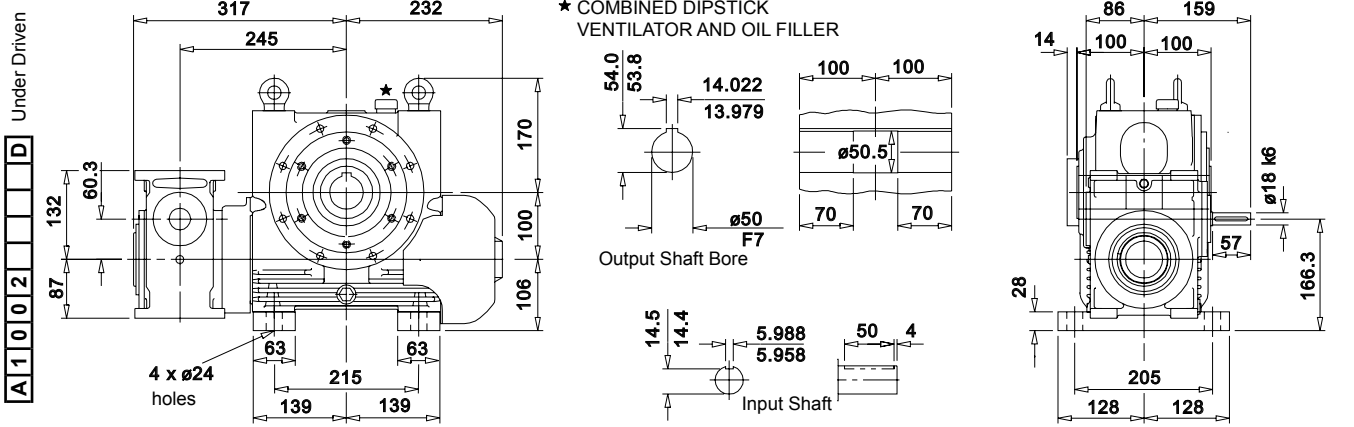

A 1 0 0 2 **M** Motorised

MOTOR FRAME SIZE	0	øP	LB (MAX)
80	114	200	255
90S	114	200	270
90L	114	200	289
100	118	250	340
112	118	250	366

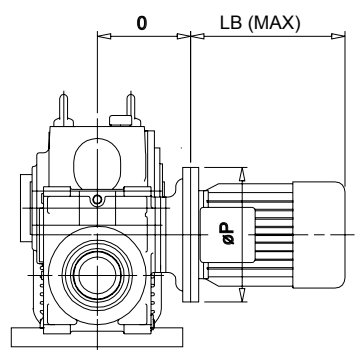

TERMINAL BOX IN SET POSITION UNLESS REQUESTED OTHERWISE

C or E FOR SINGLE EXTENSION OUTPUT SHAFT

D DOUBLE EXTENSION OUTPUT SHAFT

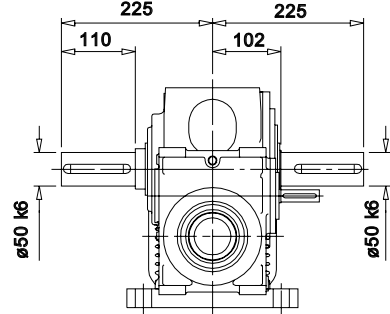
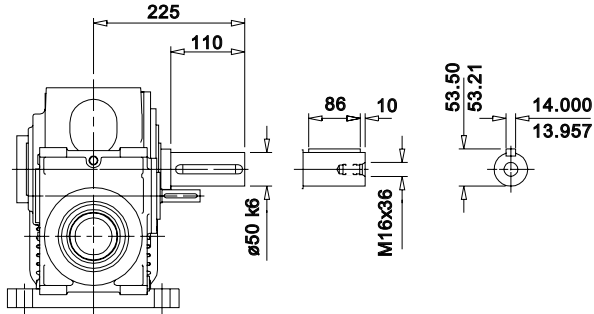

Under Driven

A 1 0 0 2 D

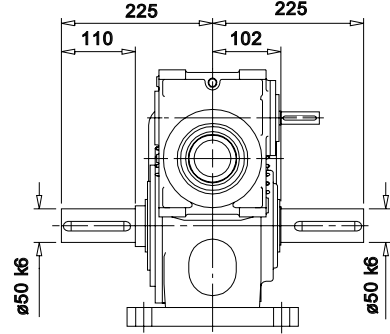
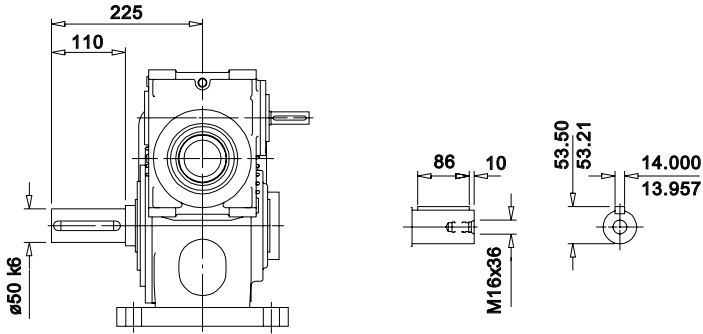

Over Driven

A 1 0 0 2 D

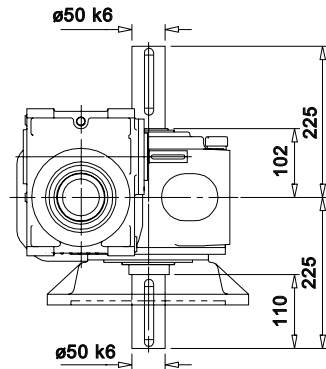
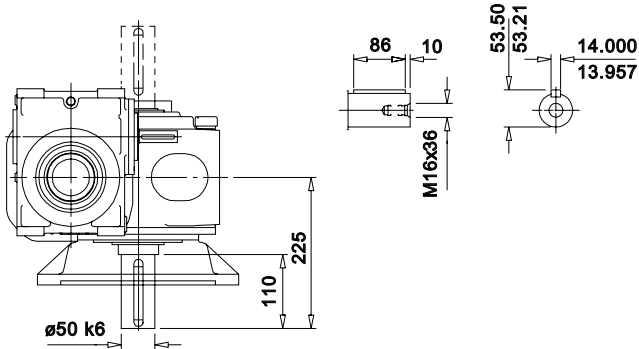

Output Flange

A 1 0 0 2 D

H SHAFT MOUNTED UNIT

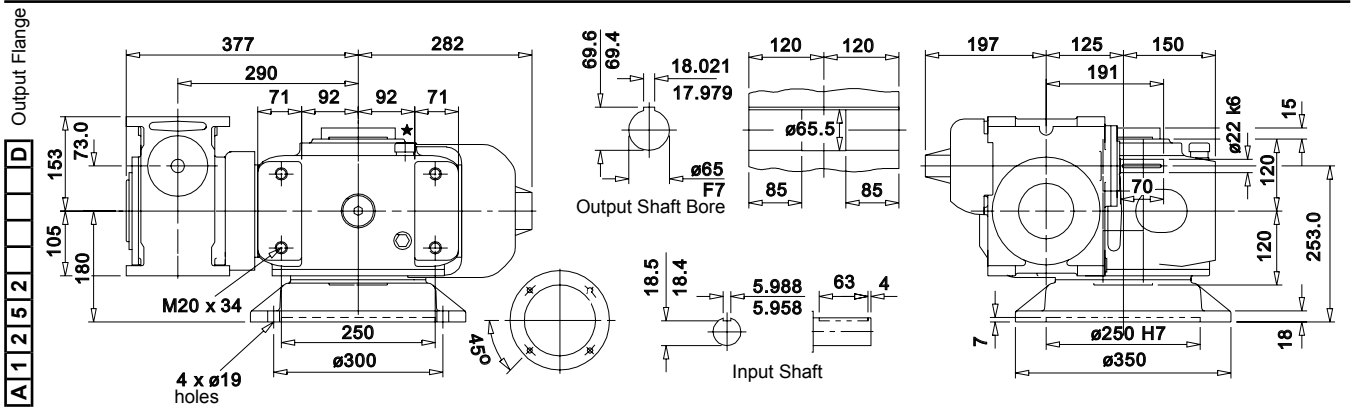
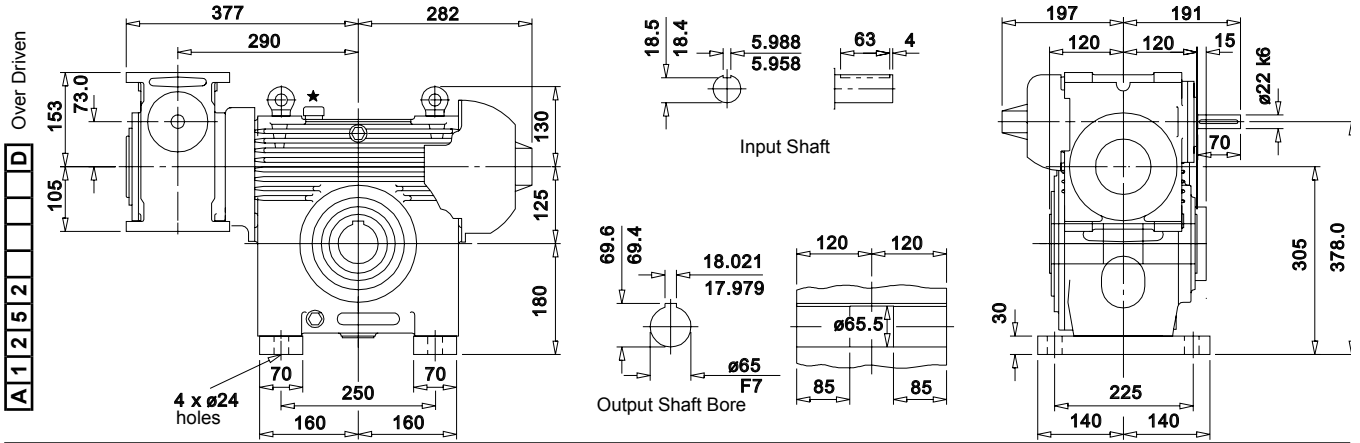
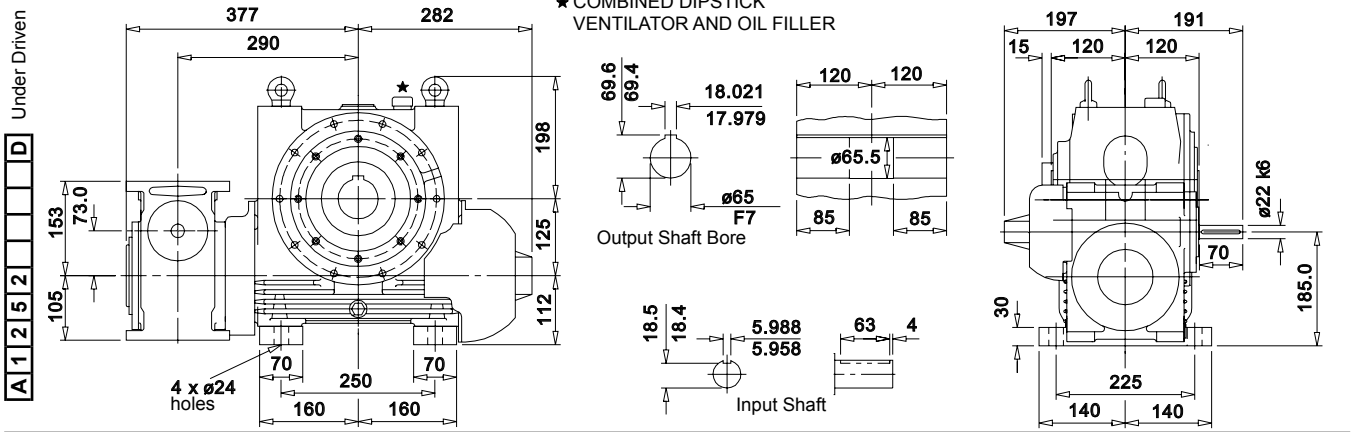

A 1 2 5 2 **M** Motorised

MOTOR FRAME SIZE	0	ϕP	LB (MAX)
80	138	200	255
90S	138	200	270
90L	138	200	289
100	138	250	340
112	138	250	366

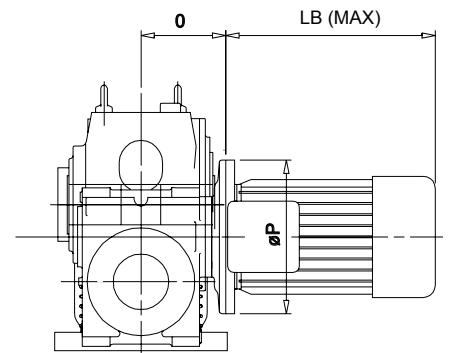

TERMINAL BOX IN SET POSITION UNLESS REQUESTED OTHERWISE

C or E FOR SINGLE EXTENSION OUTPUT SHAFT

D DOUBLE EXTENSION OUTPUT SHAFT

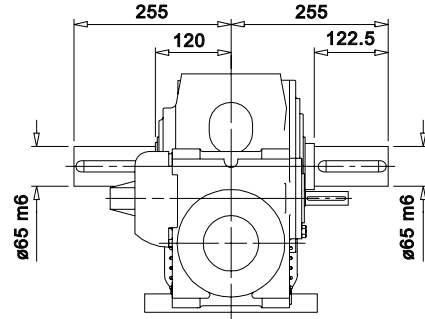
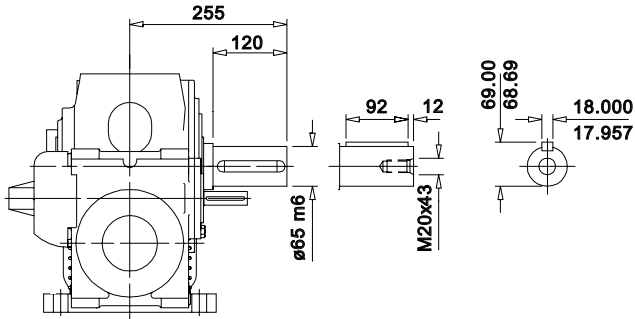

Under Driven

A 1 2 5 2 D

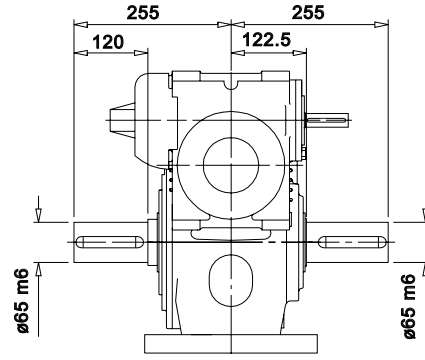
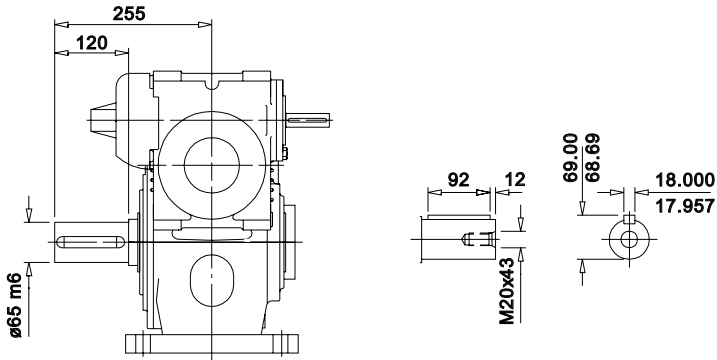

Over Driven

A 1 2 5 2 D

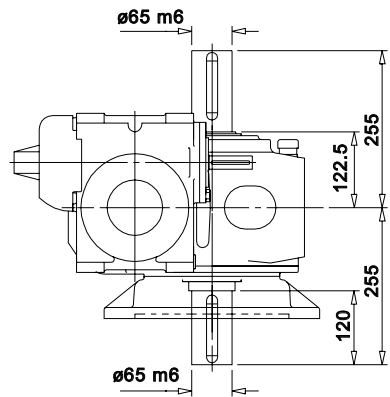
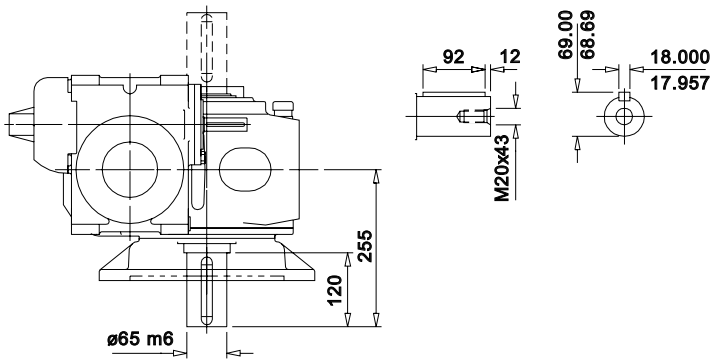

Output Flange

A 1 2 5 2 D

H SHAFT MOUNTED UNIT

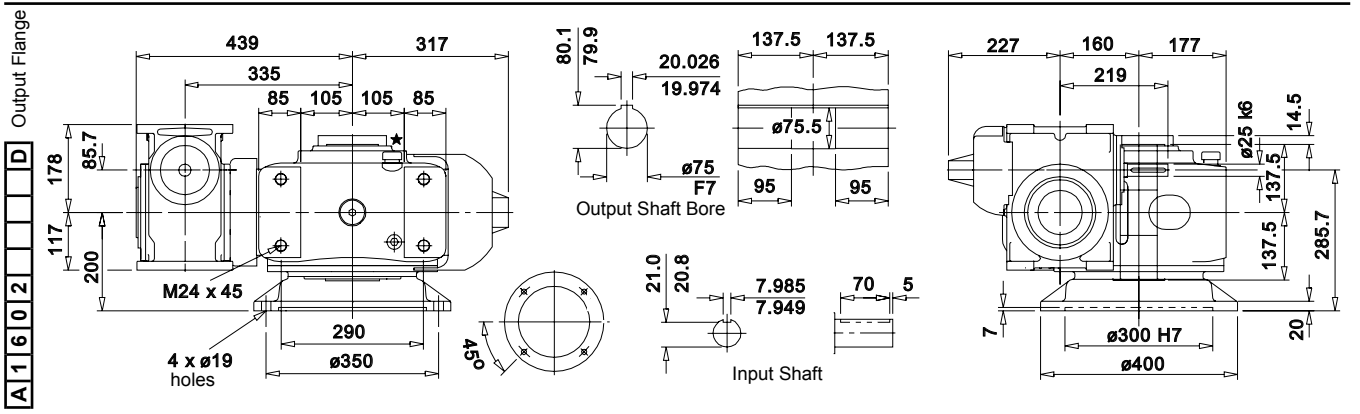
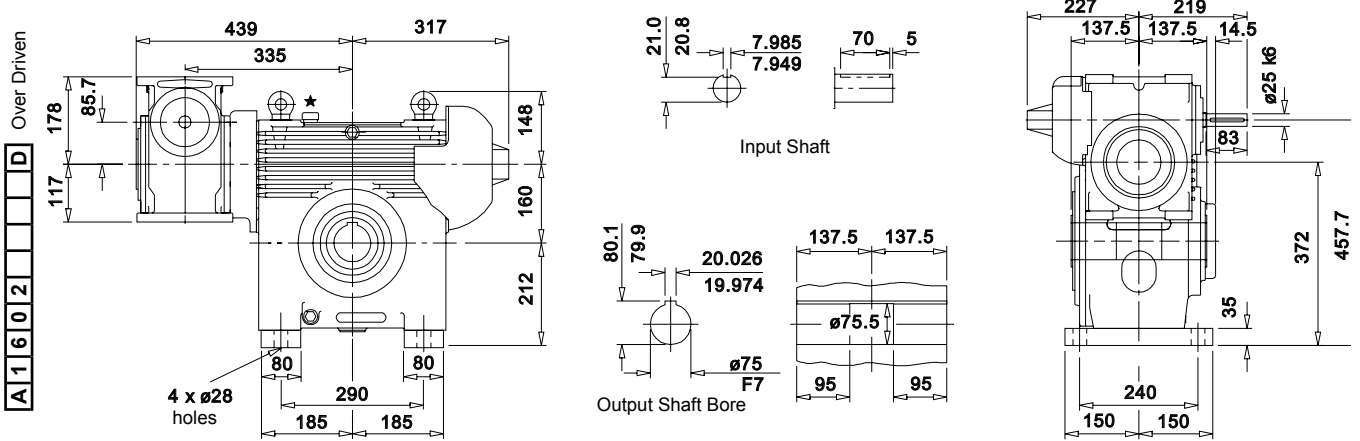
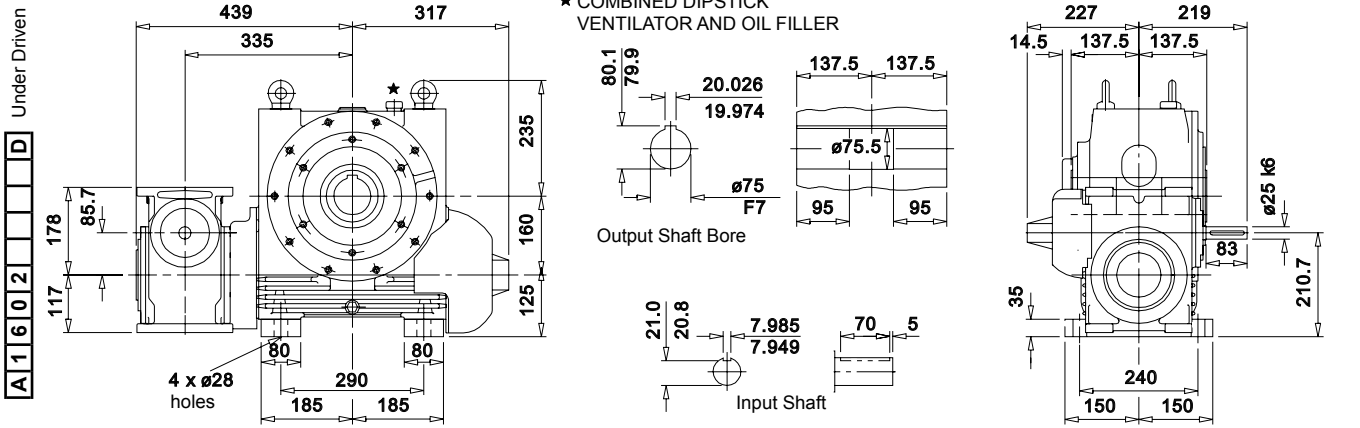

Motorised

M

MOTOR FRAME SIZE	0	øP	LB (MAX)
90S	151	200	270
90L	151	200	289
100	151	250	340
112	151	250	366
132S	158	300	403
132M	158	300	441

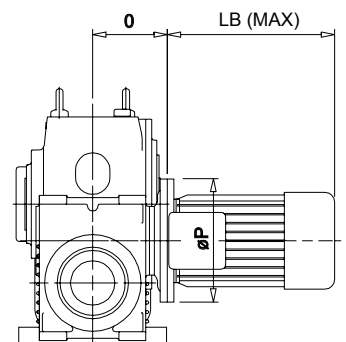

TERMINAL BOX IN SET POSITION UNLESS REQUESTED OTHERWISE

C or E FOR SINGLE EXTENSION OUTPUT SHAFT

D DOUBLE EXTENSION OUTPUT SHAFT

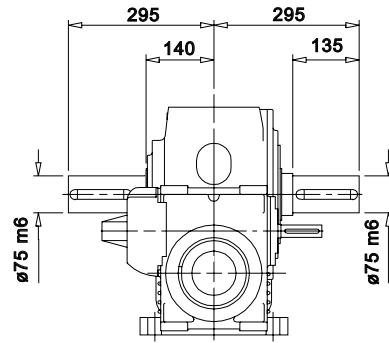
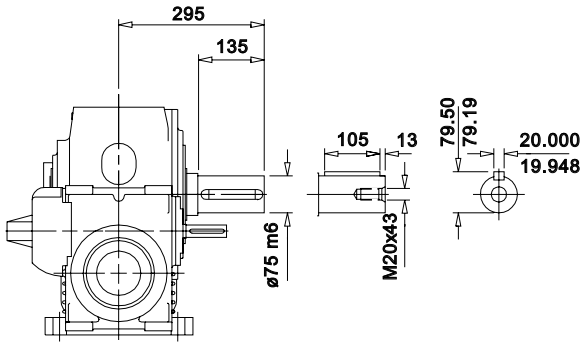

Under Driven

A 1 6 0 2 D

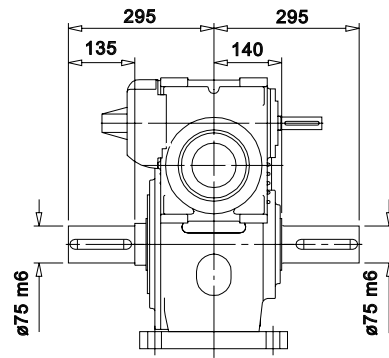
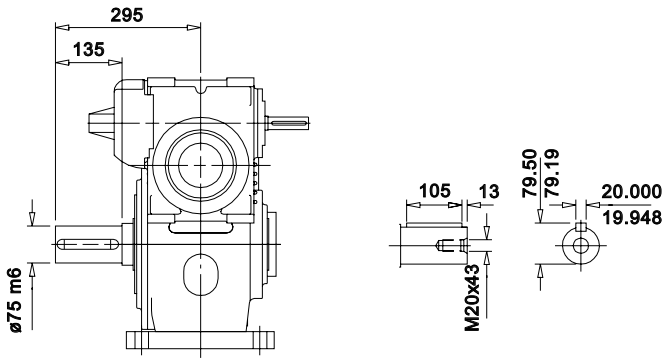

Over Driven

A 1 6 0 2 D

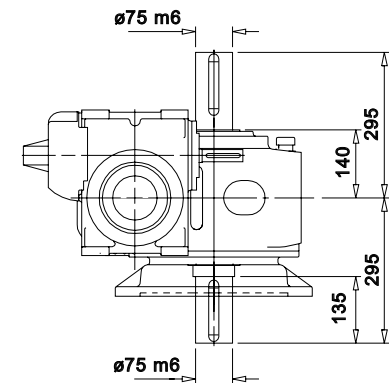
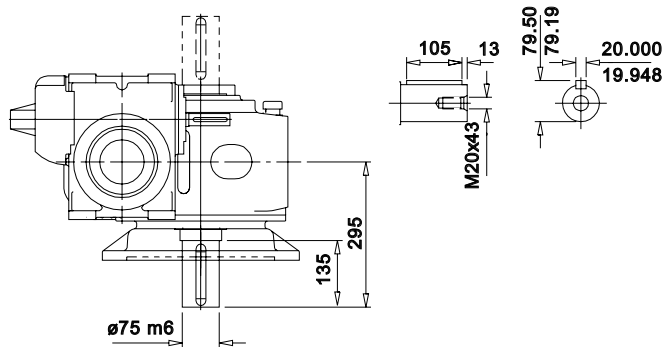

Output Flange

A 1 6 0 2 D

H SHAFT MOUNTED UNIT

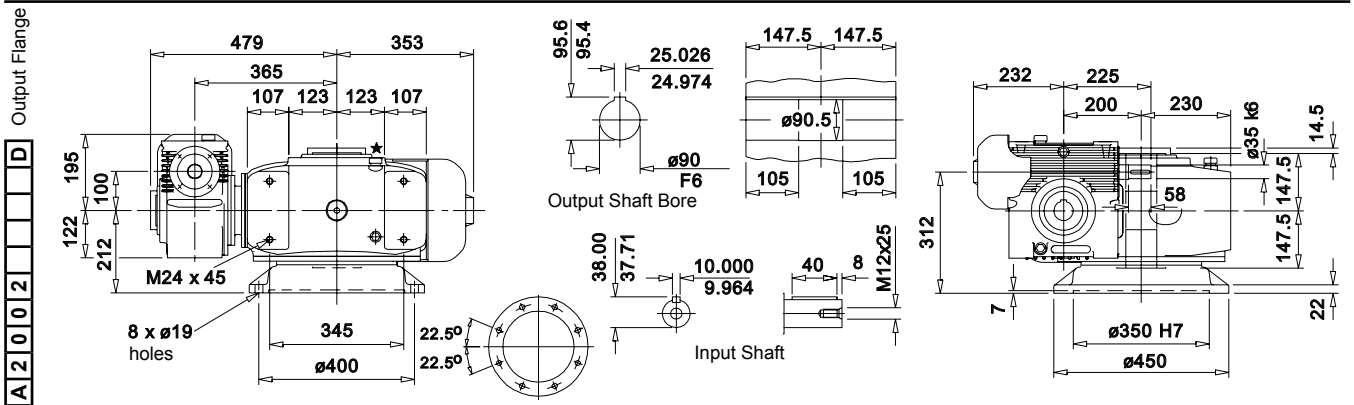
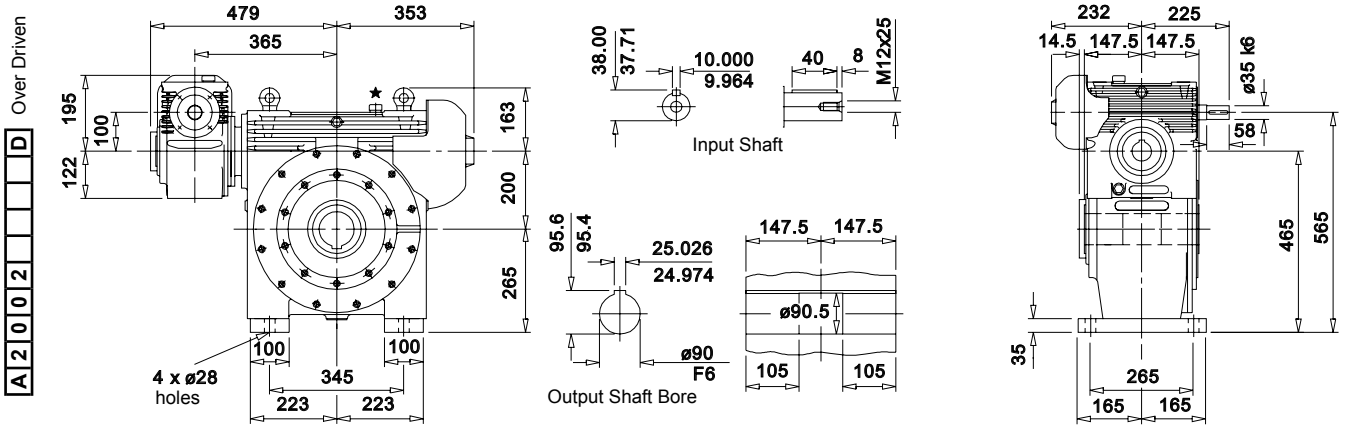
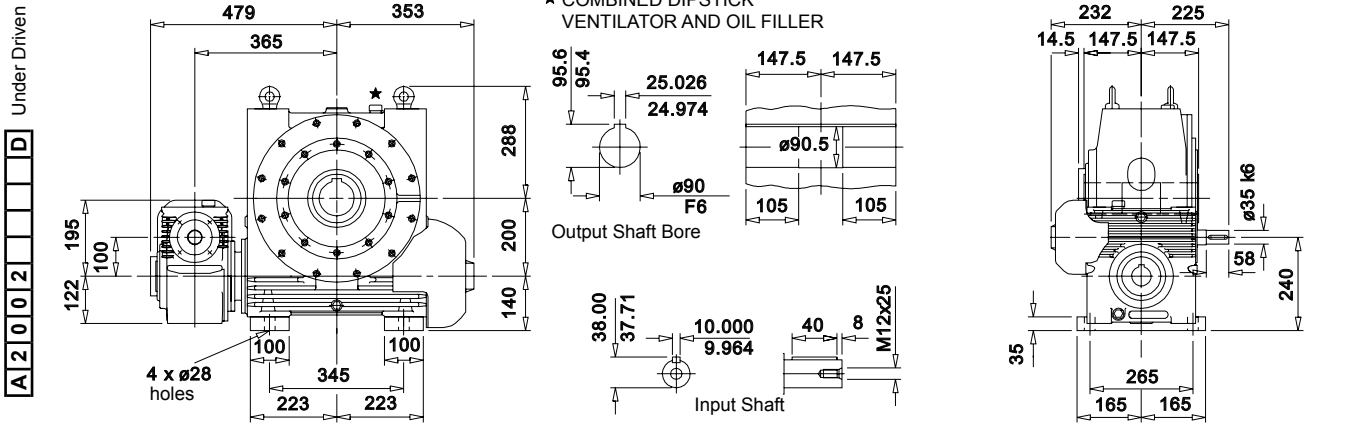

M Motorised

MOTOR FRAME SIZE	0	LB (MAX)
80	244	230
90S/L	254	270
100/112	277	340
132S/M	279	402

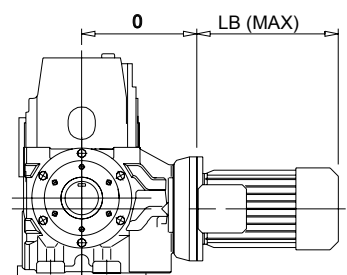

TERMINAL BOX IN SET POSITION UNLESS REQUESTED OTHERWISE

C or E FOR SINGLE EXTENSION OUTPUT SHAFT

D DOUBLE EXTENSION OUTPUT SHAFT

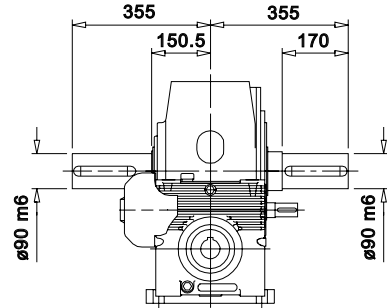
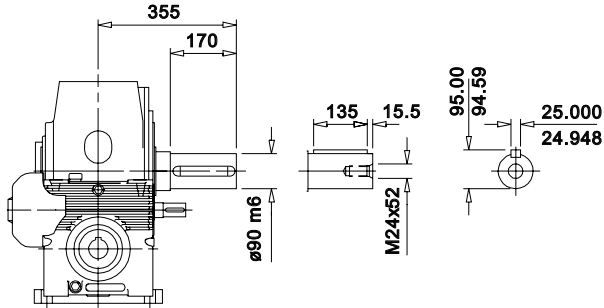

Under Driven

A 2 0 0 2 D

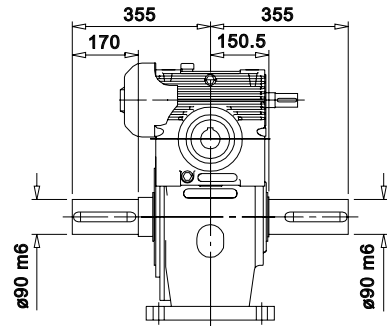
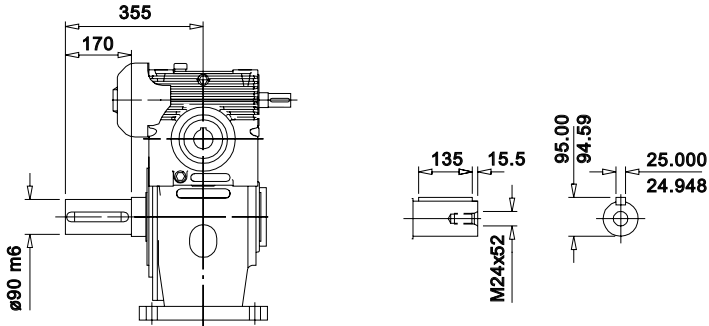

Over Driven

A 2 0 0 2 D

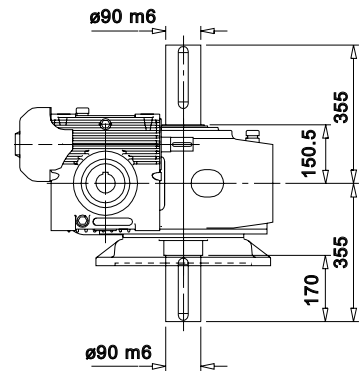
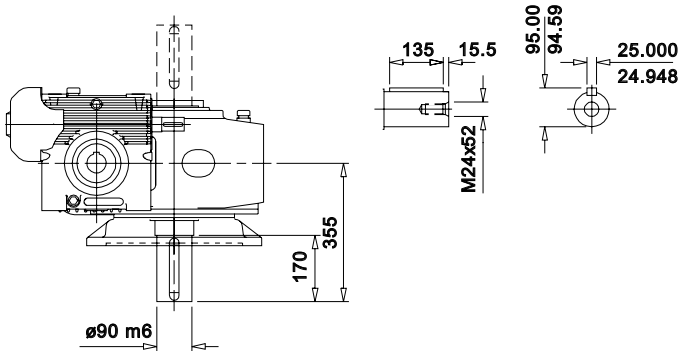

Output Flange

A 2 0 0 2 D

AGITATOR UNIT, VERSION A

Based on the standard Series A Mid Range, the Agitator unit incorporates an extended bearing housing to accommodate a larger bottom bearing and increased shaft size, thereby enhancing the units capacity to absorb the high bending loads imposed during stirrer applications.

It is recommended that as much as possible of the following information be given on enquiry to enable us to check and advise on the correct size of unit for a given duty.

- 1 Quantity.
- 2 kW power or torque required at stirrer shaft.
- 3 Type of prime mover and kW power of prime mover.
- 4 Speed or range of speeds of stirrer shaft.
- 5 Total operating time per day with full details of any loading cycles.
- 6 Nature of medium to be stirred, i.e. constant or variable density.
- 7 Dimensions of the stirrer shaft, including length from the centre of the paddle to the top of the shaft, paddle diameter and shaft extension diameter.
- 8 Weight and thrust from paddle and direction of thrust.
- 9 Details of any abnormal operating conditions, e.g. ambient temperatures, humidity, etc.
- 10 Whether coupling or other ancillary equipment are required.

The following selection procedure applies.

Selection

- 1 Check the unit power capacity from ratings tables on pages 24 - 47.
- 2 Calculate the bending moment (m) at the output shaft.

$$m = pk = \frac{\text{output torque}}{0.75r} \times k = \text{Nm}$$

- 3 Check the calculated bending moment against the shaft and bearing limitations shown in Tables 1 and 2.
- 4 Check from Table 3 the capacity of the unit to accept any specified axial thrust load.

Shaft Stress Limitations

Table 1 Allowable bending moment at the output shaft bottom bearing (Nm).

Output Shaft Torque (Nm)	Standard Units				Heavy Duty Stirrer Units			
	1002	1252	1602	2002	1002	1252	1602	2002
400	1380	2100	3500	6500	3500	5380	7850	12800
600	1330	2060	3470	6500	3470	5370	7840	12800
900	1190	1980	3420	6500	3420	5340	7820	12800
1500	580	1690	3260	6420	2870	5240	7750	12700
2200	-	950	2950	6270	1720	4690	7620	12600
3500	-	-	1770	5890	-	3260	6830	12400
5300	-	-	-	4460	-	-	5150	11470
8000	-	-	-	-	-	-	-	9270

Bearing Limitations*

Table 2 Allowable bending moment at the output shaft bottom bearing (Nm).

Output Shaft Speed (rpm)	Standard Units				Heavy Duty Stirrer Units			
	1002	1252	1602	2002	1002	1252	1602	2002
280	1430	1780	2530	4020	1790	2290	3310	5200
190	1710	2360	3300	5360	2140	3040	4320	6930
125	2170	2990	4210	6850	2720	3850	5510	8850
84	2570	3560	5120	9190	3220	4580	6700	11900
56	3020	4270	6100	10100	3790	5500	7980	13000
37	3540	5030	7150	11700	4440	6470	9360	15100
25	4170	5850	8210	13400	5230	7530	10700	17300
20 and less	4400	6300	8780	14400	5520	8110	11500	18600

* Bearing Limitations are based on 10,000 hrs L_{10} life. For other lives multiply by the following factors:

Required Life (hrs)	5,000	10,000	25,000	50,000	100,000
Factor	1.23	1	0.76	0.62	0.50

Table 3 Allowable Axial Thrust on Output Shaft (kN)

Output Shaft Speed (rpm)	Standard Units				Heavy Duty Units - Towards Gearbox				Heavy Duty Units - Away from Gearbox			
	1002	1252	1602	2002	1002	1252	1602	2002	1002	1252	1602	2002
280	1.06	1.42	1.98	2.78	1.06	1.42	1.98	2.78	5.91	6.54	8.34	14.4
190	1.79	2.39	3.33	4.68	1.79	2.39	3.33	4.68	7.22	7.93	10.1	17.6
125	2.70	3.62	5.00	7.08	2.70	3.62	5.00	7.08	8.75	9.73	12.4	21.4
84	3.80	5.10	7.05	10.0	3.80	5.10	7.05	10.0	10.6	11.7	15.0	25.8
56	5.20	6.96	9.66	13.7	5.20	6.96	9.66	13.7	12.9	14.2	18.2	31.4
37	6.85	9.17	12.7	18.1	6.85	9.17	12.7	18.1	15.5	17.1	21.9	37.7
25	8.72	11.7	16.2	23.0	8.72	11.7	16.2	23.0	18.3	20.2	25.8	44.6
20 and less	10.3	13.8	19.2	27.1	10.3	13.8	19.2	27.1	20.2	22.3	28.6	49.2

The above axial thrusts may be applied in addition to the bending moment. Higher axial thrusts can be applied but the allowable bending moment would be reduced. Consult our Application Engineers in such cases.

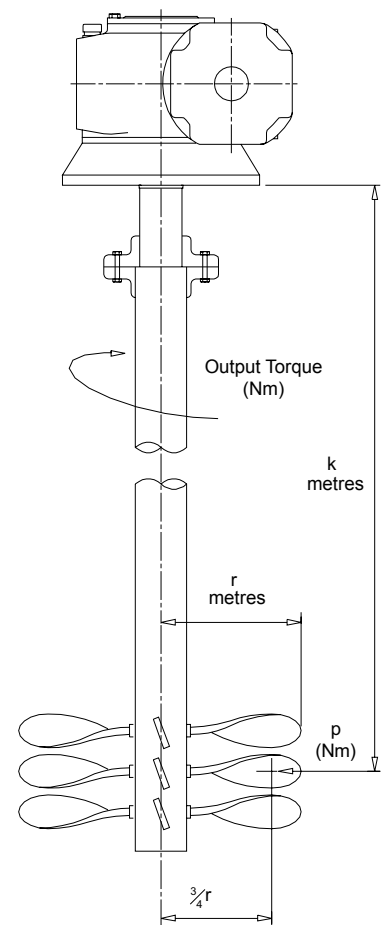

TORQUE ARM BANJO TYPE

COLUMN 9 ENTRY

T - STANDARD UNIT
WITH BANJO
TORQUE ARM ON
LEFT

X - STANDARD UNIT
WITH BANJO
TORQUE ARM ON
RIGHT

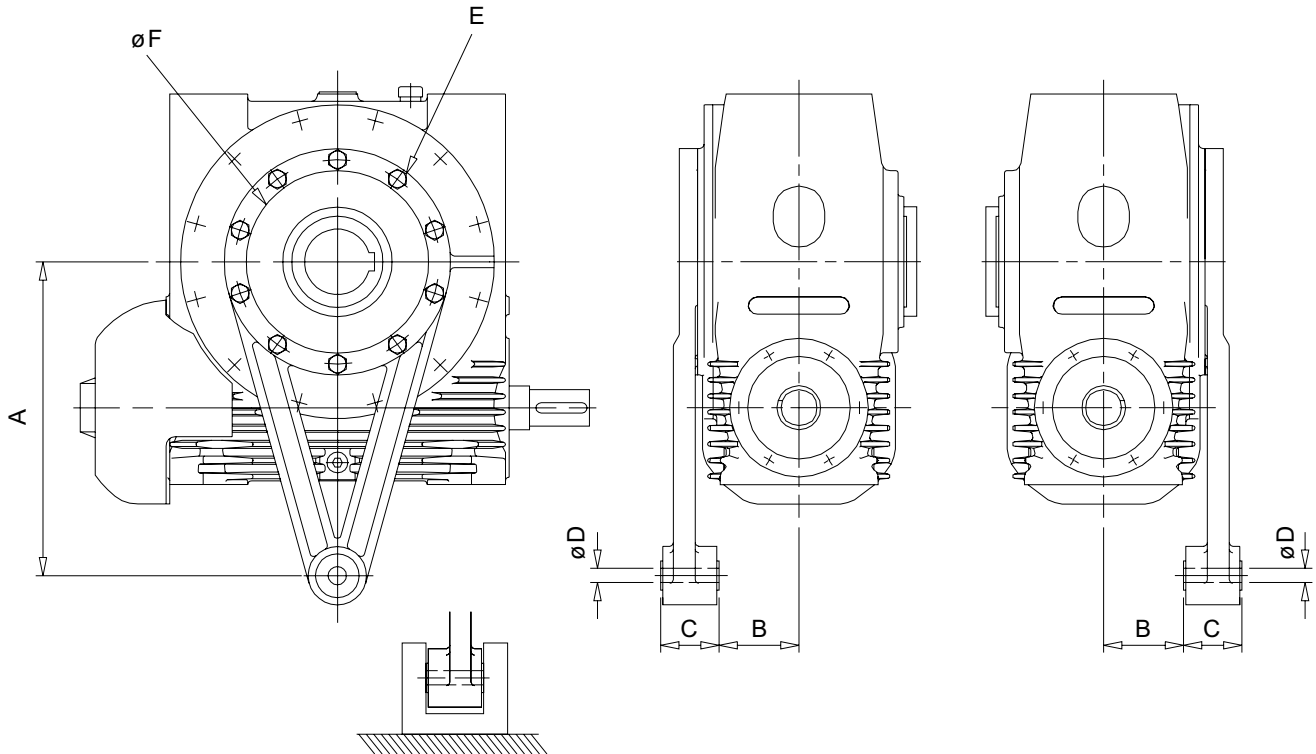

SIZE OF UNIT	A	B	C	øD	E	øF (Spigot dia)
1002	250	67	60	16.4	6 x M12 on a 155 pcd	132.000/131.937
1252	310	77.5	60	16.4	8 x M12 on a 195 pcd	170.000/169.937
1602	380	84	80	25	6 x M16 on a 230 pcd	200.000/199.928
2002	430	110.5	80	25	10 x M16 on a 280 pcd	250.000/249.928

NOTE: It is recommended that the torque arm is fitted on the side of the unit adjacent to the driven machine.

OUTPUT SHAFT ROTATION TO BE SPECIFIED WHEN THE UNIT IS IN MOUNTING POSITION 1 (AS SHOWN BELOW)

OUTPUT SHAFT ROTATION AC

- Free Rotation - Anticlockwise
- Locked - Clockwise

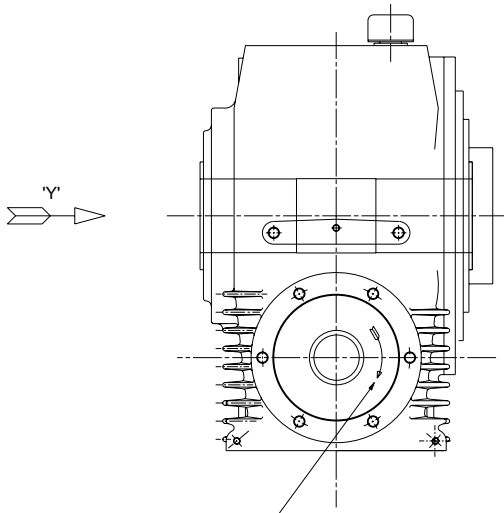

INPUT SHAFT ROTATION

OUTPUT SHAFT ROTATION

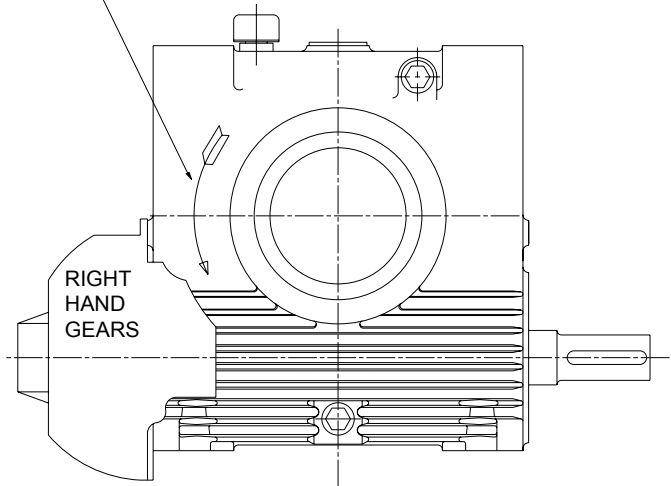

VIEW IN DIRECTION OF ARROW 'Y'

OUTPUT SHAFT ROTATION CW

- Free Rotation - Clockwise
- Locked - Anticlockwise

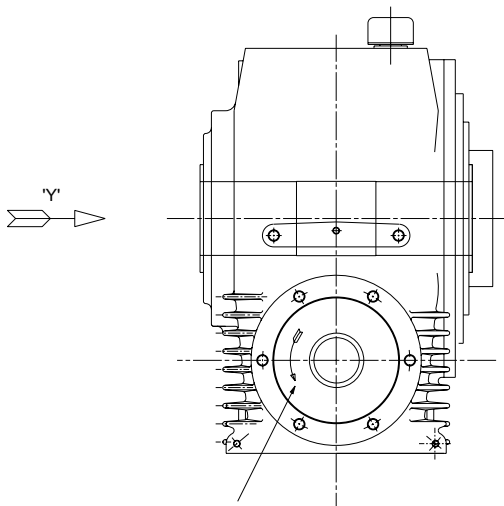

INPUT SHAFT ROTATION

OUTPUT SHAFT ROTATION

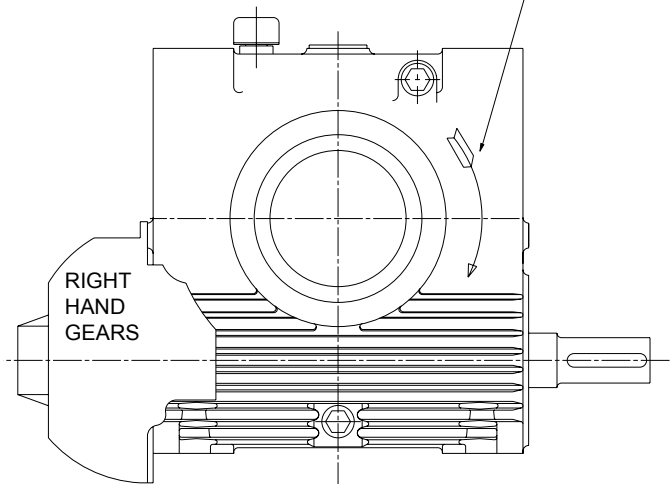

VIEW IN DIRECTION OF ARROW 'Y'

SINGLE REDUCTION

		1002				1252				1602				2002			
COLUMN 9 ENTRY		B, D	F, H	A	C	B, D	F, H	A	C	B, D	F, H	A	C	B, D	F, H	A	C
SHAFT MOUNTED	Unit Weight	67	73	-	-	93	103	-	-	140	157	-	-	212	239	-	-
	Weight Packed	79	86	-	-	107	118	-	-	158	176	-	-	245	269	-	-
	Volume Packed (m3)	0.08	0.09	-	-	0.12	0.14	-	-	0.18	0.19	-	-	0.24	0.25	-	-
SINGLE EXTENSION OUTPUT	Unit Weight	74	81	86	81	103	114	119	114	155	174	182	174	236	266	274	266
	Weight Packed	88	95	101	95	119	131	136	131	176	196	204	196	272	299	307	299
	Volume Packed (m3)	0.12	0.10	0.10	*	0.17	0.17	0.16	*	0.24	0.24	0.22	*	0.34	0.33	0.30	*

* VOLUME DEPENDENT ON SIZE OF WHEELSHAFT EXTENSION (FOR STANDARD EXTENSION, VOLUME AS STANDARD AGITATOR A UNIT)

DOUBLE REDUCTION

		1002		1252		1602		2002	
COLUMN 9 ENTRY		B, D	F, H	B, D	F, H	B, H	F, H	B, D	F, H
SHAFT MOUNTED	Unit Weight	93	100	133	144	201	220	303	333
	Weight Packed	107	114	150	162	223	243	351	378
	Volume Packed (m3)	0.11	0.14	0.15	0.18	0.24	0.28	0.42	0.32
SINGLE EXTENSION OUTPUT SHAFT	Unit Weight	100	108	144	154	218	235	327	360
	Weight Packed	112	120	159	170	238	256	372	402
	Volume Packed (m3)	0.17	0.15	0.21	0.22	0.32	0.33	0.44	0.41

ALL WEIGHTS IN KG ALL WEIGHTS EXCLUDE LUBRICANT

COLUMN 9 ENTRY B, D - BASE MOUNTED
F, H - FLANGE MOUNTED
A - AGITATOR
C - COOLING TOWER

NOTE: FOR SHIPPING SPECIFICATION OF DOUBLE REDUCTION MOTORISED UNITS ADD WEIGHT AND VOLUME OF MOTORS AND MOTOR ADAPTORS TO THE FIGURES SHOWN ABOVE

IMPORTANT

Product Safety Information

General - The following information is important in ensuring safety. It **must** be brought to the attention of personnel involved in the selection of the equipment, those responsible for the design of the machinery in which it is to be incorporated and those involved in its installation, use and maintenance.

The equipment will operate safely provided it is selected, installed, used and maintained properly. As with any power transmission equipment **proper precautions must** be taken as indicated in the following paragraphs, to ensure safety.

Potential Hazards - these are **not** necessarily listed in any order of severity as the degree of danger varies in individual circumstances. It is important therefore that the list is studied in its entirety:-

- 1) Fire/Explosion
 - (a) Oil mists and vapour are generated within gear units. It is therefore dangerous to use naked lights in the proximity of gearbox openings, due to the risk of fire or explosion.
 - (b) In the event of fire or serious overheating (over 300 °C), certain materials (rubber, plastics, etc.) may decompose and produce fumes. Care should be taken to avoid exposure to the fumes, and the remains of burned or overheated plastic/rubber materials should be handled with rubber gloves.
- 2) Guards - Rotating shafts and couplings must be guarded to eliminate the possibility of physical contact or entanglement of clothing. It should be of rigid construction and firmly secured.
- 3) Noise - High speed gearboxes and gearbox driven machinery may produce noise levels which are damaging to the hearing with prolonged exposure. Ear defenders should be provided for personnel in these circumstances. Reference should be made to the Department of Employment Code of Practice for reducing exposure of employed persons to noise.
- 4) Lifting - Where provided (on larger units) only the lifting points or eyebolts must be used for lifting operations (see maintenance manual or general arrangement drawing for lifting point positions). Failure to use the lifting points provided may result in personal injury and/or damage to the product or surrounding equipment. Keep clear of raised equipment.
- 5) Lubricants and Lubrication
 - (a) Prolonged contact with lubricants can be detrimental to the skin. The manufacturer's instruction must be followed when handling lubricants.
 - (b) The lubrication status of the equipment must be checked before commissioning. Read and carry out all instructions on the lubricant plate and in the installation and maintenance literature. Heed all warning tags. Failure to do so could result in mechanical damage and in extreme cases risk of injury to personnel.
- 6) Electrical Equipment - Observe hazard warnings on electrical equipment and isolate power before working on the gearbox or associated equipment, in order to prevent the machinery being started.
- 7) Installation, Maintenance and Storage
 - (a) In the event that equipment is to be held in storage, for a period exceeding 6 months, prior to installation or commissioning, application engineering must be consulted regarding special preservation requirements. Unless otherwise agreed, equipment must be stored in a building protected from extremes of temperature and humidity to prevent deterioration.

The rotating components (gears and shafts) must be turned a few revolutions once a month (to prevent bearings brinelling).
 - (b) External gearbox components may be supplied with preservative materials applied, in the form of a "waxed" tape overwrap or wax film preservative. Gloves should be worn when removing these materials. The former can be removed manually, the latter using white spirit as a solvent.

Preservatives applied to the internal parts of the gear units do not require removal prior to operation.
 - (c) Installation must be performed in accordance with the manufacturer's instructions and be undertaken by suitably qualified personnel.
 - (d) Before working on a gearbox or associated equipment, ensure that the load has been removed from the system to eliminate the possibility of any movement of the machinery and isolate power supply. Where necessary, provide mechanical means to ensure the machinery cannot move or rotate. Ensure removal of such devices after work is complete.
 - (e) Ensure the proper maintenance of gearboxes in operation. Use only the correct tools and approved spare parts for repair and maintenance. Consult the Maintenance Manual before dismantling or performing maintenance work.
- 8) Hot Surfaces and Lubricants
 - (a) During operation, gear units may become sufficiently hot to cause skin burns. Care must be taken to avoid accidental contact.
 - (b) After extended running the lubricant in gear units and lubrication systems may reach temperatures sufficient to cause burns. Allow equipment to cool before servicing or performing adjustments.
- 9) Selection and Design
 - (a) Where gear units provide a backstop facility, ensure that back-up systems are provided if failure of the backstop device would endanger personnel or result in damage.
 - (b) The driving and driven equipment must be correctly selected to ensure that the complete machinery installation will perform satisfactorily, avoiding system critical speeds, system torsional vibration, etc.
 - (c) The equipment must not be operated in an environment or at speeds, powers, torques or with external loads beyond those for which it was designed.
 - (d) As improvements in design are being made continually the contents of this catalogue are not to be regarded as binding in detail, and drawings and capacities are subject to alterations without notice.

The above guidance is based on the current state of knowledge and our best assessment of the potential hazards in the operation of the gear units.

Any further information or clarification required may be obtained by contacting an Application Engineer.

PRODUCTS IN THE RANGE

Serving an entire spectrum of mechanical drive applications from food, energy, mining and metal; to automotive, aerospace and marine propulsion, we are here to make a positive difference to the supply of drive solutions.

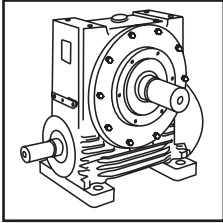

Series A
Worm Gear units
and geared motors
in single & double
reduction types

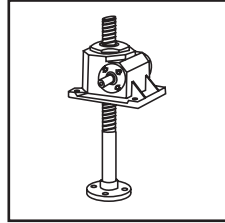

Series BD
Screwjack worm
gear unit

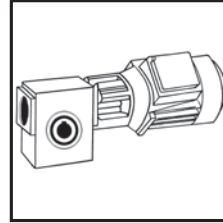

Series BS
Worm gear unit

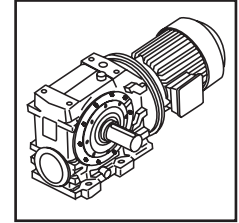

Series C
Right angle drive
helical worm geared
motors & reducers

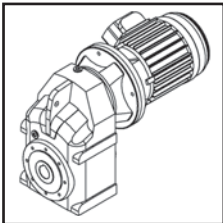

Series F
Parallel angle helical
bevel helical geared
motors & reducers

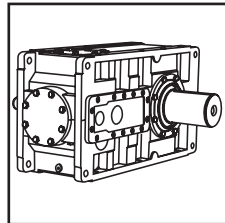

Series G
Helical parallel shaft
& bevel helical right
angle drive gear
units

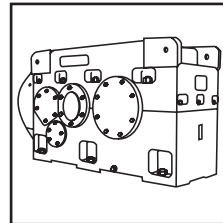

Series H
Large helical parallel
shaft & bevel helical
right angle drive units

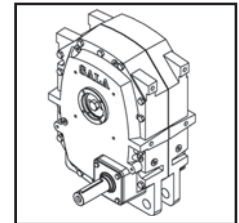

Series J
Shaft mounted
helical speed
reducers

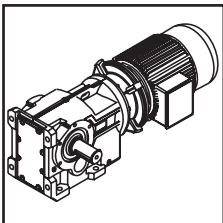

Series K
Right angle helical
bevel helical geared
motors & reducers

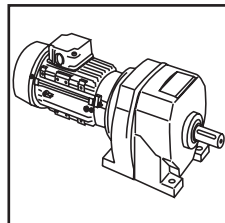

Series M
In-line helical geared
motors & reducers

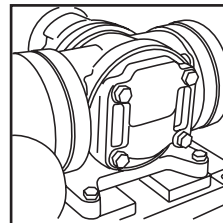

Roloid Gear Pump
Lubrication and fluid
transportation pump

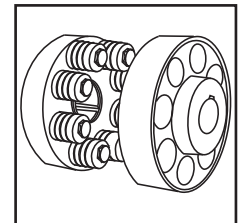

**Series X
Cone Ring**
Pin and bush
elastomer coupling

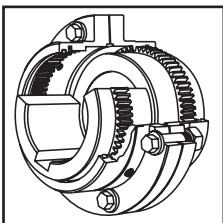

**Series X
Gear**
Torsionally rigid,
high torque coupling

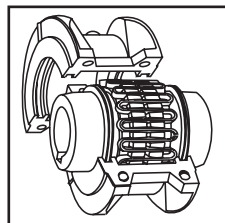

**Series X
Grid**
Double flexing steel
grid coupling

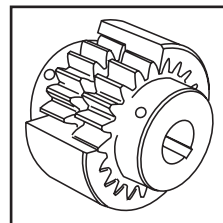

**Series X
Nylon**
Gear coupling with
nylon sleeve

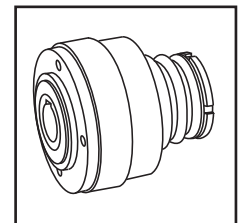

**Series X
Torque Limiter**
Overload protection
device



We offer a wide range of repair services and many years experience of repairing demanding and highly critical transmissions in numerous industries.

We can create custom engineered transmission solutions of any size and configuration.

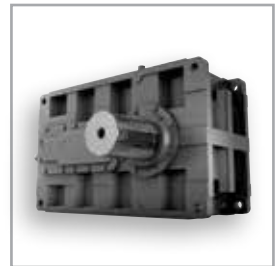
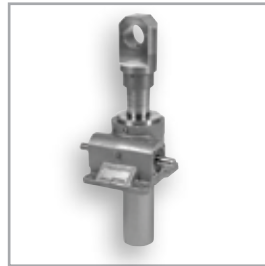

benzlers*
radicon*

BCI_{nv}
elektromotoren

Gentstraat 187
B-8770 Ingelmunster
t +32 0 51 30 49 73
t +32 0 51 30 98 63
f +32 0 51 31 41 02
Info@bcl.be
www.bcl.be